



\*Patent Pending

## TL4500

**Easily change belts, blades and service front tires**

**Tractor Lift can be used out of the box on most Zero-Turn brands available through major retailers.**

### Maintenance

Store in a clean dry place.

Recommended tire pressure - 30 PSI.

Before each use:

Always check tire pressure.

Always inspect unit for damage.

Always check fasteners for tightness.

### Tools required for assembly:

1. 9/16" wrench and/or socket
2. Adjustable wrench
3. Pliers



**If there are any missing parts, or if you have any questions on assembly, operation, maintenance or safety, please call 800-652-2321**

### WARNINGS

- Always use the stabilizer bar provided when using tractor lift.
- Make sure stabilizer bar is properly in place before starting any work on tractor.
- Read and understand all safety and operating instructions before using the tractor lift. Never allow anyone unfamiliar with these instructions to use the tractor lift.
- Read and understand all safety and operating instructions provided by the tractor's manufacturer before using tractor lift.
- Never lay under the tractor or mowing deck.
- When using lift, keep all bystanders, including children, away.
- This tractor lift must be only used for lifting and lowering to and from a level and stable surface.
- Never use in wet conditions.
- Do not attempt to lift the front and back of the tractor at the same time.
- Do not use tractor lift as an automotive lift, or for any other use for which it is not intended or designed.
- If tractor lift is bowing while lifting or lowering your tractor, which indicates an overload condition, remove the tractor immediately.
- Do not attempt to lift or lower any power equipment while motor is running.
- Never engage blades while using tractor lift.
- Always disconnect spark plug wire from tractor before beginning any work on tractor.
- Do not exceed the rated capacity of the tractor lift - 275 lbs.
- Failure to follow these warnings may result in property damage and/or serious bodily injury.

### SAFETY INSTRUCTIONS

- Be sure to read and follow all safety instructions and warnings. Failure to follow these instructions may result in damage to the product and/or serious personal injury.
- Danger of serious personal injury exists. Serious personal injury can occur when using a lifting device.
- Never attempt to ride any vehicle up or down the tractor lift.
- Do not climb onto tractor while tractor is in the elevated position.
- When working on the front of the tractor always place wheel chocks in back of the rear wheels/tires.
- Always raise and lower tractor lift in a controlled fashion; do not allow the tractor to drop too quickly, damage could occur.
- Make sure lifting arms are aligned and set to the proper distance apart so that the equipment being loaded is well balanced on the lift.
- Do not remove warning decals from product.
- Before each use, always check for any worn, loose, or damaged parts on the tractor lift. If any damage is present, DO NOT USE THE TRACTOR LIFT.
- Periodically check the fasteners to make sure they are still tight and in place.
- Keep lift surface clean by occasionally cleaning with water and any mild detergent.
- Do not add to or try to modify the tractor lift in any way. Any modifications will void any warranties.
- Failure to abide by the warnings and read the safety instructions may result in loss of load, damage to lift and/or property, serious personal and/or fatal injury.

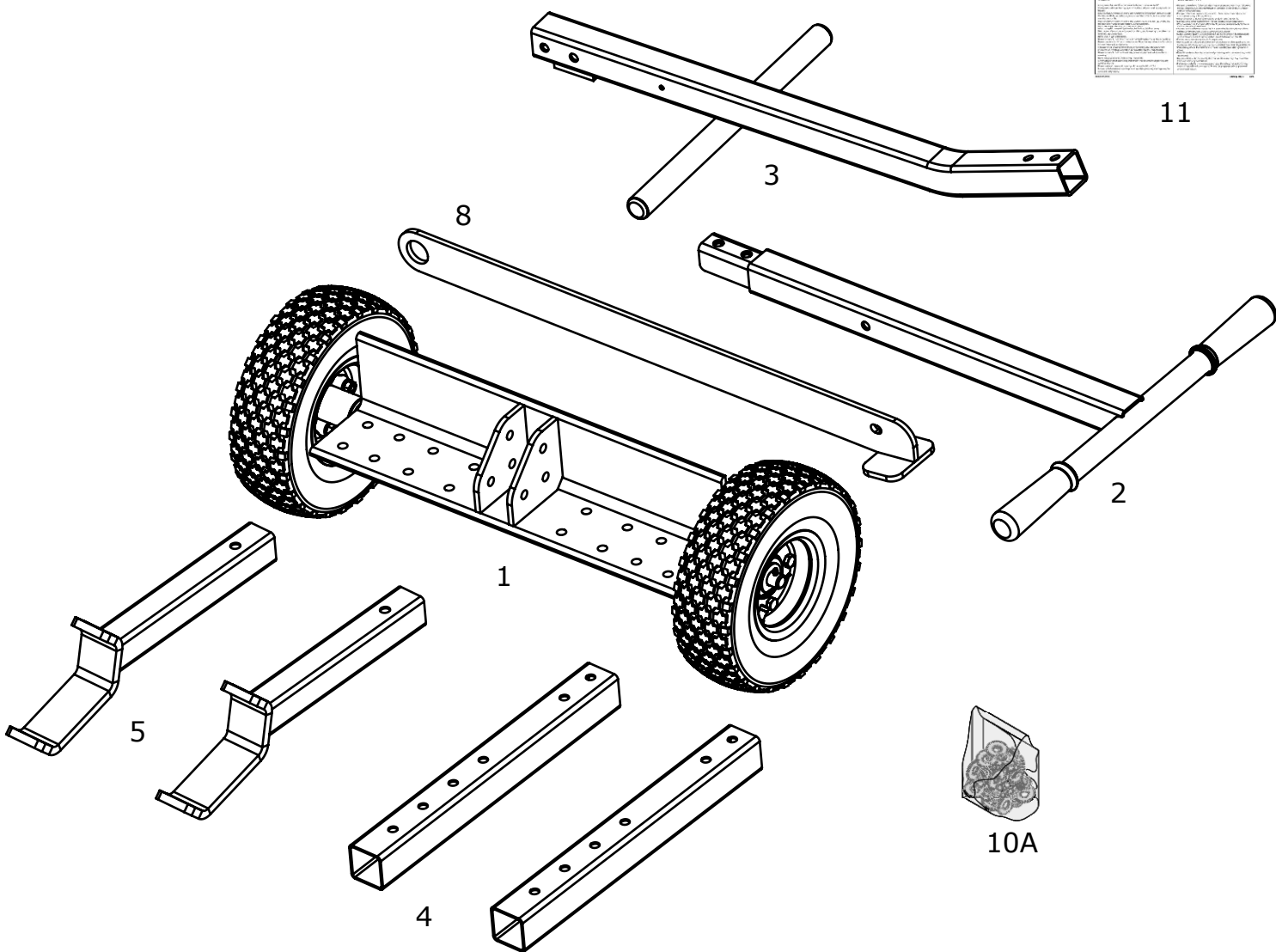

REF NO	QTY	DESCRIPTION	REF NO	QTY	DESCRIPTION
1	1	Angle Frame	5	2	Lift Tube
2	1	Handle Top	8	1	Stabilizer Bar
3	1	Handle Bottom	10A	1	Hardware Bag #1
4	2	Receiver Tube	11	1	Assembly Guide

### TOOLS REQUIRED FOR ASSEMBLY

9/16" Wrench and/or Socket  
Adjustable wrench  
Pliers

### MAINTENANCE

Store unit in a clean dry place.  
Recommended tire pressure - 30 PSI.  
Before each use:  
Always check tire pressure.  
Always inspect unit for damage.  
Always check fasteners for tightness.

## HARDWARE CONTENTS

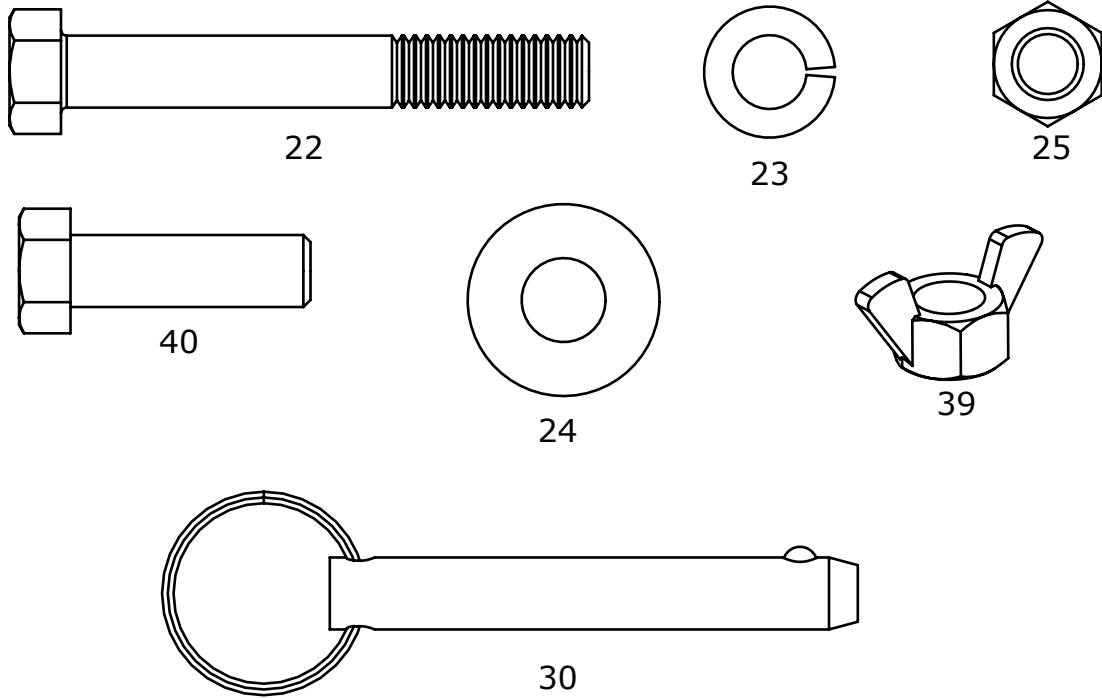

## HARDWARE CONTENTS

REF NO	QTY	PART NUMBER	DESCRIPTION
22	6	310051	3/8"-16 x 2-3/4" Hex Bolt
23	8	310072	3/8" Split Lock Washer
24	6	310073	3/8" USS Flat Washer
25	6	310062	3/8"-16 Hex Nut
30	3	310081	3/8" Ring Grip Pin
39	1	310064	3/8" Wing Nut
40	2	310055	3/8"-16 x 1-1/4" Hex Bolt

## Assemble Tractor Lift

### Attach Lift Tubes to Angle Frame

- Attach receiver tubes ( 4 ) to angle frame ( 1 ) using bolts ( 22 ), flat washers ( 24 ), split lock washers ( 23 ) and hex nuts ( 25 ).
- Slide lift tubes (5) into receiver tubes (4) secure with ring grip pins (30).

Note: Over-tightening receiver bolts ( 22 ) could cause damage to lift tubes ( 4 ).

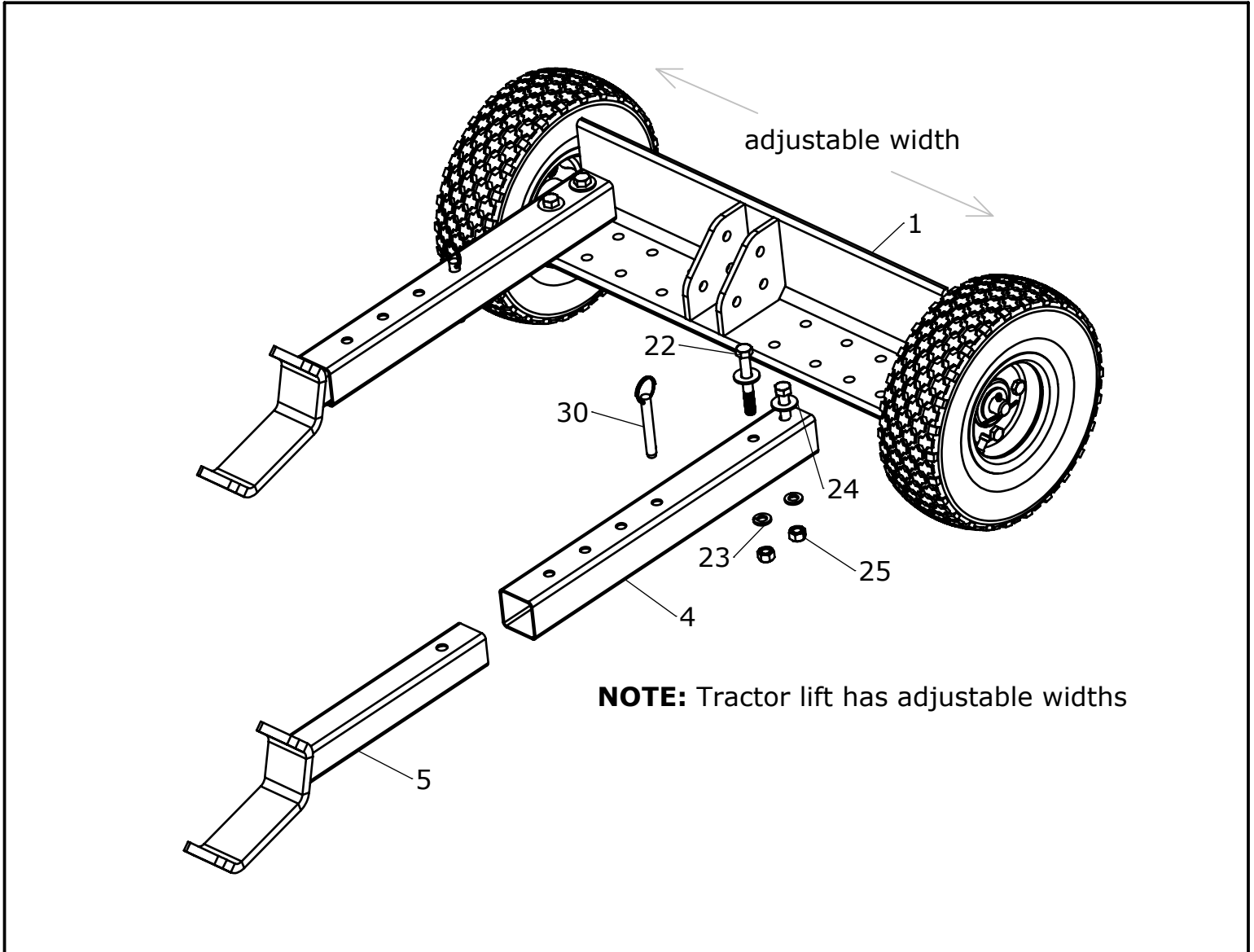

# Assemble Tractor Lift

## Attach Handle to Angle Frame

- Step 1. Attach handle bottom ( 3 ) to angle frame ( 1 ) using hex bolt ( 22 ), flat washer ( 24 ), split lock washer ( 23 ) and hex nut ( 25 ).
- Step 2. Insert ring grip pin ( 30 ), plugs ( 38 ) and grips ( 37 ) as shown.
- Step 3. Insert handle top ( 2 ) into handle bottom ( 3 ). Secure with hex bolts ( 40 ), and split lock washers ( 23 ).
- Step 4. Slide stabilizer bar ( 8 ) onto Foot Bar Tube. Insert hex bolt ( 22 ) and flat washer ( 24 ) through side of handle top ( 2 ). Tighten using split lock washer ( 23 ) and hex nut ( 25 ).
- Step 5. Align hole in stabilizer bar ( 8 ) with hex bolt ( 22 ). Tighten using wing nut ( 39 ).

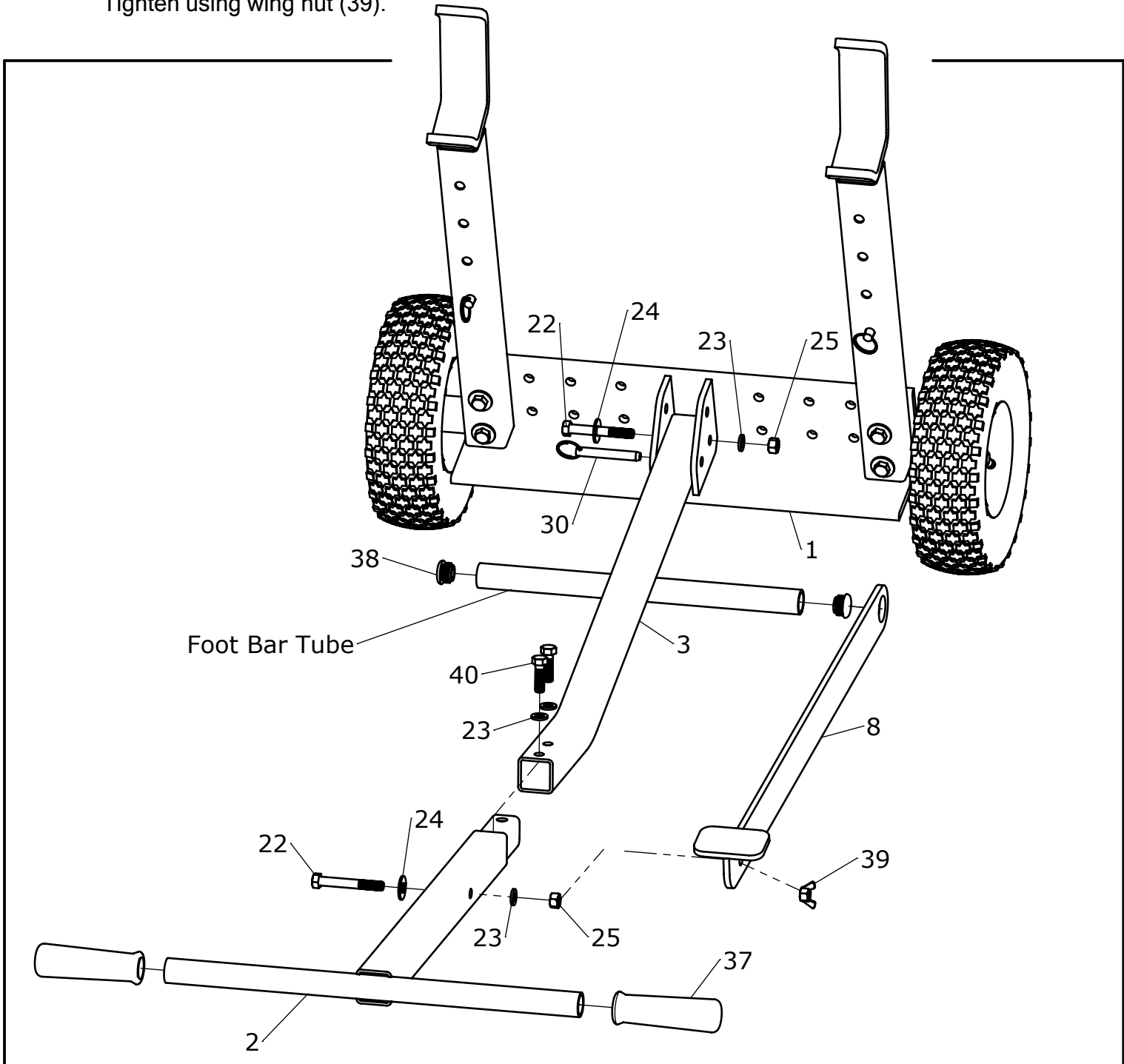

## Using the Tractor Lift

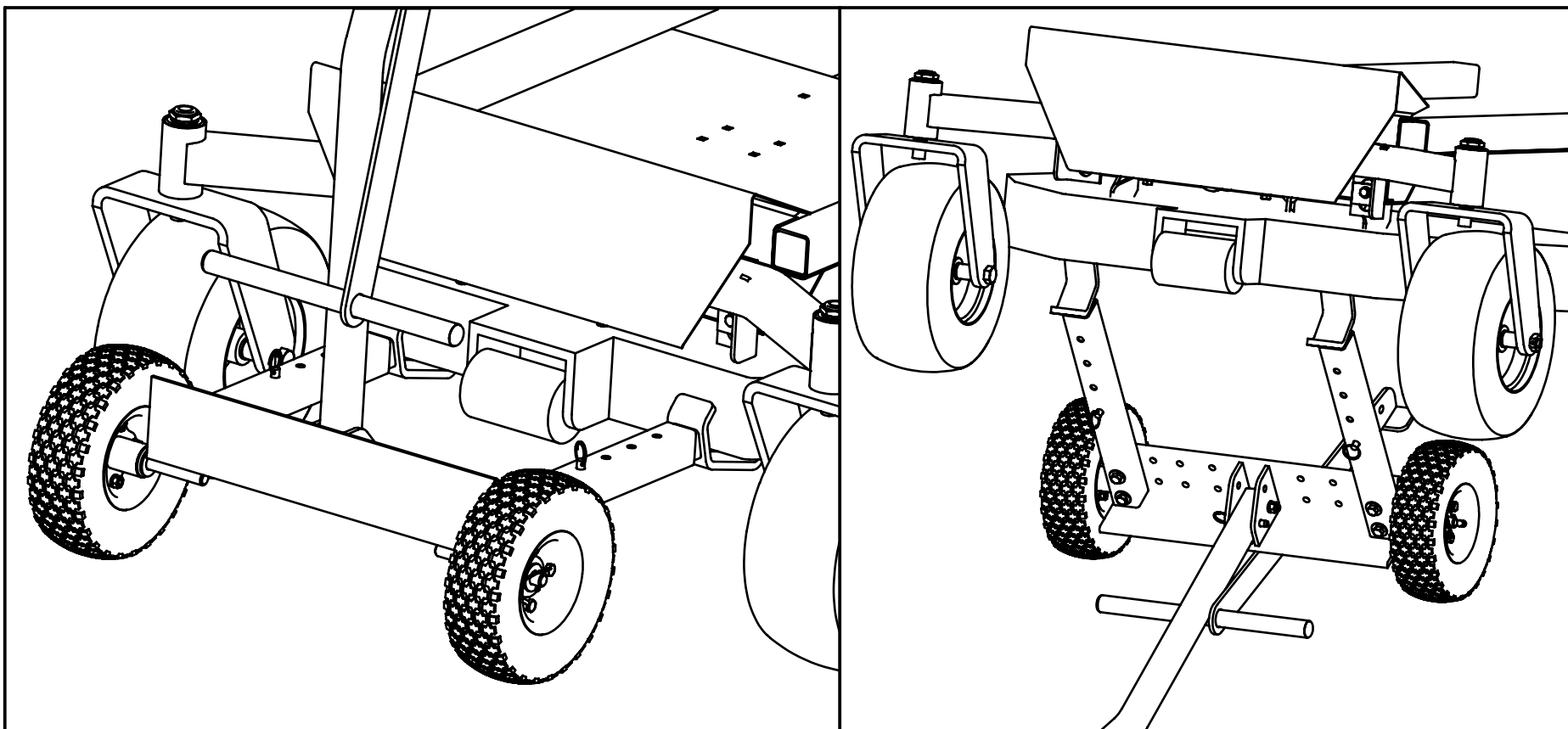

- Center Tractor Lift in front of tractor.
- Align lift tube claws with mowing deck and roll Tractor Lift forward to engage.
- Check that claws are securely hooked under the mowing deck.
- Place foot onto foot bar and apply continuous forward pressure with foot while pulling down on tractor lift handle.
- Once lifted, the weight of the tractor will automatically force the handle down into the correct position.
- **IMPORTANT:** Stabilizer bar **MUST** be engaged immediately after raising the tractor. See Step 3 on page 7 for instructions.

# OPERATION

## Using the Tractor Lift

### Step 3. Engaging Stabilizer Bar

Stabilizer bar **MUST** be engaged immediately after raising the tractor.

**WARNING:** Failure to engage stabilizer bar may result in serious personal injury and or property damage.

- Remove securing wingnut ( 39 ) from tube handle. Slide stabilizer bar ( 8 ) from foot bar tube.
- Turn stabilizer bar 180 degrees as shown at bottom of Figure 1.
- Position stabilizer bar under base of unit between wheels.
- Slide stabilizer bar back onto foot bar tube as shown in Figure 2.

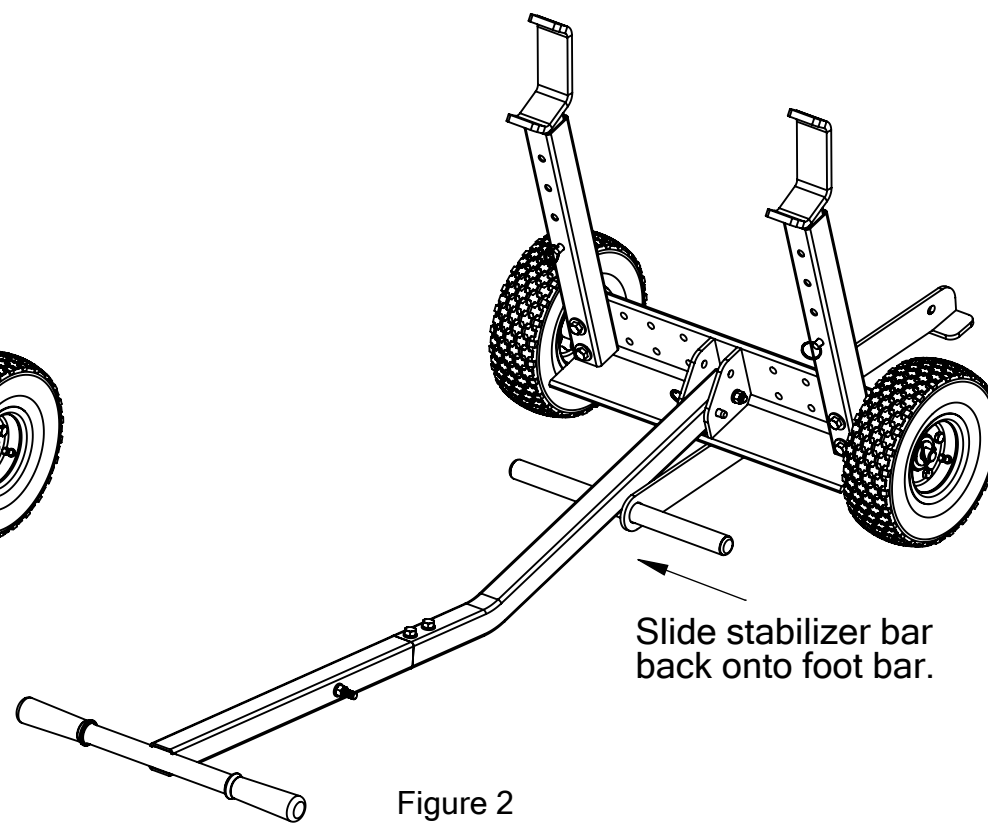
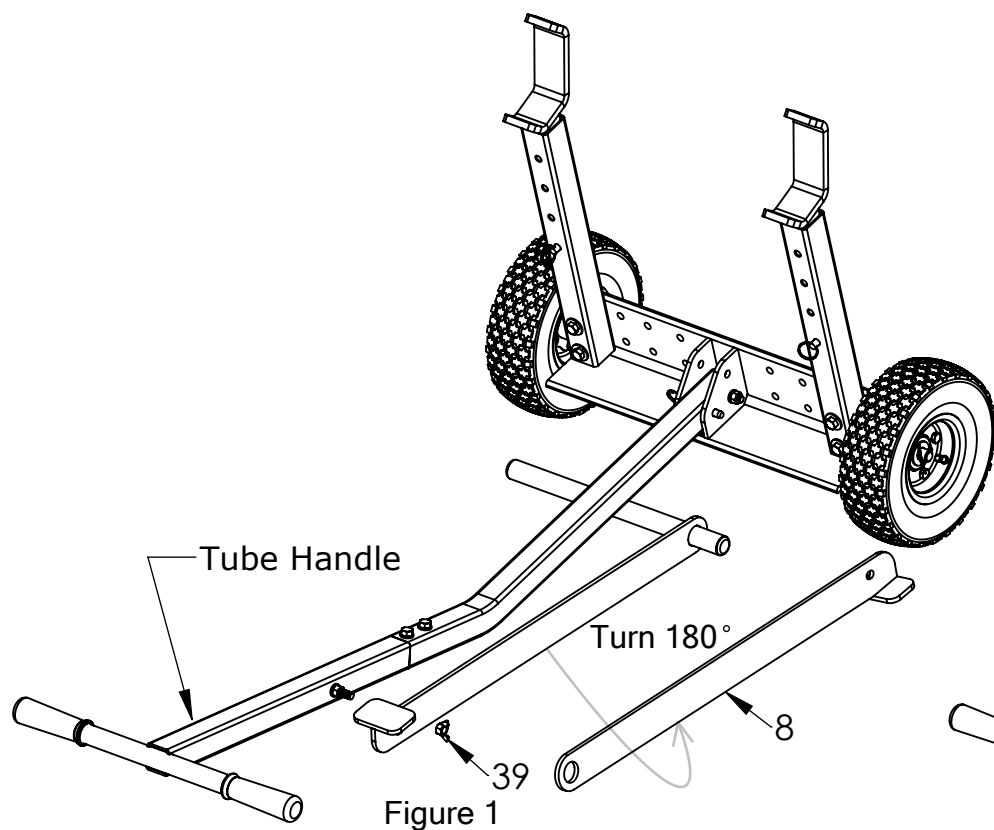

## Service Parts List

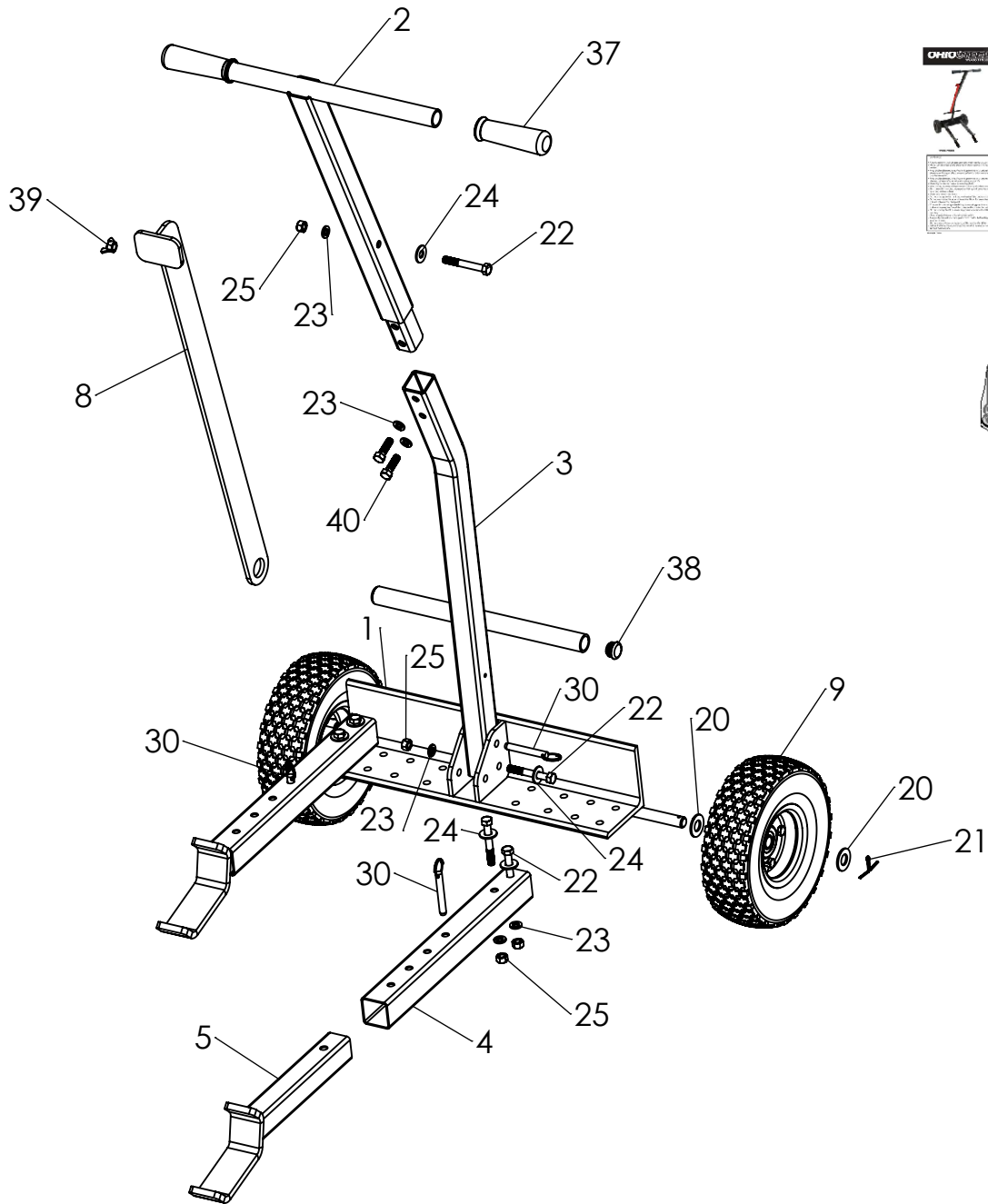

11



10A

REF. NO.	PART NO.	AMT.	DESCRIPTION	REF. NO.	PART NO.	AMT.	DESCRIPTION
1	510011	1	Angle Frame	21	300081	2	Cotter Pin 1/8" x 1-1/2"
2	510024	1	Handle Top	22	310051	6	3/8"-16 x 2-3/4" Hex Bolt
3	510032	1	Handle Bottom	23	310072	8	3/8" Split Lock Washer
4	410091	2	Receiver Tube	24	310073	6	3/8" USS Flat Washer
5	510042	2	Lift Tube	25	310062	6	3/8"-16 Hex Nut
8	51006	1	Stabilizer Bar	30	310081	3	3/8" x 2-1/8" Ring Grip Pin
9	310011	2	Tire 4.10/3.50-4	37	310181	2	Handle Grip
10A	310035	1	Hardware Bag #1	38	310221	2	Tube Plug RT8-1
11	6000161	1	Assembly Manual	39	310064	1	3/8"-16 Wing Nut
20	310071	4	5/8" SAE Flat Washer	40	310055	2	3/8"-16 x 1-1/4" Hex Bolt