

## **Foreword**

Congratulations on the purchase of your new power take-off (PTO) generator. We hope that you will find your IMD PTO generator a pleasure to use.

The operating instructions will help you to become acquainted with your new equipment. Important safety instructions and hazard warnings will help you to use your PTO generator safely.

The PTO generator provides a quick source of electrical power for the agricultural environment.

Please observe the following points before putting your PTO generator into operation:

- Read its Owner's Manual carefully and in its entirety.
- Observe and follow all safety instructions, including the warning labels on the PTO generator at all times.
- Immediately replace any defective warning labels so that no unsuspecting persons are injured.
- Read the operating instructions from the tractor and power take-off shaft manufacturers and follow all instructions carefully.



If there is anything that you do not understand, please contact our service Hotline at 864. 968.0858 for clarification and technical assistance.

We reserve the right to make technical modifications and changes at any time with or without notice.

**Table of Contents**

|                                    |           |
|------------------------------------|-----------|
| <b>Foreword</b>                    | <b>1</b>  |
| <b>Table of Content</b>            | <b>2</b>  |
| <b>Intended Usage</b>              | <b>3</b>  |
| <b>Conditions of Warranty</b>      | <b>3</b>  |
| <b>Safety Instructions</b>         | <b>6</b>  |
| <b>General Safety Instructions</b> | <b>7</b>  |
| Mechanical Danger                  | 7         |
| Danger from exhaust fumes          | 8         |
| Danger from Electrical power       | 8         |
| Danger from explosion              | 9         |
| <b>Preparing for use:</b>          | <b>10</b> |
| Delivery Conditions                | 10        |
| Mounting onto concrete slab        | 10        |
| Optional 3-point hitch             | 11        |
| Optional heavy duty trailer        | 12        |
| Electrical Installation            | 12        |
| Grounding the generator            | 13        |
| Installing PTO shaft               | 14        |
| Checking the gearbox for oil level | 14        |
| <b>Operation</b>                   | <b>15</b> |
| Switch ON                          | 15        |
| Starting the generator             | 15        |
| Switching OFF                      | 16        |
| <b>Maintenance, cleaning, care</b> | <b>16</b> |
| Visual Inspection                  | 17        |
| Functional Test                    | 17        |
| Keeping the generator clean        | 17        |
| Changing the gear oil              | 18        |
| Long term storage                  | 19        |
| Maintenance schedule               | 19        |
| Technical Specification            | 20        |
| <b>Exploded view alternator</b>    | <b>20</b> |
| <b>Circuit Diagram</b>             | <b>21</b> |
| <b>Parts List Panel</b>            | <b>21</b> |
| <b>Exploded view panel</b>         | <b>22</b> |
| <b>Accessories</b>                 | <b>23</b> |
| <b>Terminology</b>                 | <b>23</b> |
| <b>Troubleshooting</b>             | <b>24</b> |
| <b>Spare Parts</b>                 | <b>24</b> |

## **Intended Usage**

The intended usage of this PTO generator is the generation of electrical power.

The IMD power generator can be used to feed electrical power into the circuit of a building (provided the proper electrical safety switch has been installed by a licensed electrician) or to plug appropriate electrical applications into its power outlets to operate them in case of a power outage.

Any different or additional use of the equipment is not within the scope of the intended usage and shall be at the owner's or operator's own risk and peril.

The manufacturer disclaims any and all liability for any such unauthorized, additional or different use, and shall be held harmless for any and all losses and damages, including property damage, personal injury and death, resulting from any such unauthorized, additional or different use, to the operator, any bystanders or any other person or property.

Any modifications to any IMD PTO generator shall be made only in accordance with the manufacturer's specifications, upon written approval by the manufacturer and shall be performed only by a trained licensed professional.

Unauthorized modifications of the equipment or any unauthorized use of the equipment or use outside the scope of the intended usage shall void the manufacturer's warranty.

## **Conditions of Warranty**

**NOTICE: THIS LIMITED WARRANTY GIVES YOU CERTAIN RIGHTS. PLEASE READ CAREFULLY.**

The manufacturer provides a limited warranty and warrants the product to be free from defects in material and workmanship from the date of original purchase from an authorized dealer for the duration of the warranty. This warranty is not transferable and only covers the initial original purchaser. Proof of purchase (original sales receipt) is required for any warranty claim.

- No warranty coverage will be provided without proof of purchase or warranty card.

In the event of a defect in material or workmanship during the 24 month period from the date of the original purchase, the manufacturer or its authorized dealer or repair center will, at the manufacturer's sole discretion, repair or replace the product on the terms and conditions and with the limitations and exclusions as set forth below:

1. The manufacturer may repair the product with new or reconditioned parts or replace the product with a new or reconditioned product of the same or substantially similar or equivalent kind, and any replaced products or parts become the property of the manufacturer.
2. This limited warranty does not cover damage caused by abuse, neglect, accident, disaster, misuse, mishandling, improper packaging for shipping, improper installation, improper operation, overload, mechanical impact, chemical impact or damage caused by any chemicals other than the ones authorized to be used in connection with the operation of the product, unauthorized repair or modification, use of non-proprietary or aftermarket spare parts, or failure to follow the manufacturer's instructions with respect to the proper handling, operation, installation, service and maintenance of the product.
3. Normal wear and tear is not covered by this limited warranty.
4. To obtain warranty service, contact your dealer or the manufacturer to receive shipping instructions and return authorization.



Service Hotline  
1.864.968.0858

5. To obtain warranty service, defective parts must be shipped to the manufacturer. The purchaser must pay the shipping charges to ship the parts to the manufacturer. If the entire generator is returned for warranty service the gearbox must be drained of all fluids, packaged in its original container, and shipping charges must be paid by the purchaser. Return charges will be paid by the manufacturer.
6. This limited warranty does not cover any on-site repair.
7. Any repairs done under this limited warranty do not extend the warranty period beyond the date of 24 months from the original purchase date.

8. This limited warranty shall be null and void in case of abuse, neglect, accident, disaster, misuse, mishandling, improper packaging for shipping, improper operation, overload, mechanical impact, chemical impact or damage caused by any chemicals other than the ones authorized to be used in connection with the operation of the product, unauthorized repair or modification, use of non-proprietary or after-market spare parts, or failure to follow the manufacturer's instructions with respect to the proper handling, operation, installation, service and maintenance of the product.
9. This limited warranty is limited to replacement of the defective parts of the product or the whole product, if found defective.
10. This limited warranty covers the labor required to repair the unit for the first 12 months only.

ANY IMPLIED WARRANTY OF MERCHANTABILITY OR FITNESS FOR A PARTICULAR PURPOSE ON THIS PRODUCT IS LIMITED TO THE 24-MONTHS DURATION OF THIS WRITTEN WARRANTY. ALL WARRANTIES SET FORTH IN THIS WARRANTY ARE LIMITED TO THE 24 MONTHS FROM THE DATE OF THE ORIGINAL PURCHASE. NO WARRANTIES WHATSOEVER WILL COVER THE PRODUCT BEYOND THE 24-MONTHS PERIOD. HOWEVER, SOME STATES DO NOT ALLOW LIMITATIONS ON HOW LONG AN IMPLIED WARRANTY LASTS, SO IN SUCH STATES THE ABOVE LIMITATION MAY NOT APPLY TO YOU.

IF THIS PRODUCT IS DEFECTIVE, YOUR ONLY REMEDY IS REPAIR OR REPLACEMENT, AS DESCRIBED ABOVE. UNDER NO CIRCUMSTANCES WILL THE MANUFACTURER, ITS DISTRIBUTORS, DEALERS OR AGENTS BE LIABLE FOR INCIDENTAL OR CONSEQUENTIAL DAMAGES, INCLUDING ANY LOST PROFITS, LOST COMPENSATION OF ANY KIND, OR OTHER DAMAGES CAUSED BY THE USE OF THIS PRODUCT OR INABILITY TO USE IT, EVEN IF THE DEALER OR MANUFACTURER HAS BEEN ADVISED OF SUCH LIABILITY CLAIMS OR OTHER CLAIMS.

SOME STATES DO NOT ALLOW THE EXCLUSION OR LIMITATION OF INCIDENTAL OR CONSEQUENTIAL DAMAGES, SO THE ABOVE LIMITATION OR EXCLUSION MAY NOT APPLY TO YOU. THIS WARRANTY GIVES YOU SPECIFIC RIGHTS, AND YOU MAY HAVE OTHER RIGHTS WHICH MAY VARY FROM STATE TO STATE.

## **Safety Instructions**

Read these operating instructions carefully, as well as those of the tractor and PTO shaft manufacturer. For safety reasons, you should not use the generator set until you have understood all the instructions.



This is the safety alert symbol. It is used to alert you to potential personal injury hazards. Obey all safety messages that follow this symbol to avoid possible injury or death.



Wherever the Danger sign appears in this manual it indicates an imminently hazardous situation which, if not avoided, will result in death or serious personal injury.



The Warning sign indicates a potentially hazardous situation which, if not avoided, could result in death or serious personal injury.



Ground (earth) terminal - Be sure to ground (earth) the generator.



This symbol tells you to read the operating instructions of the tractor manufacturer and the PTO shaft manufacturer.

## General Safety Instructions

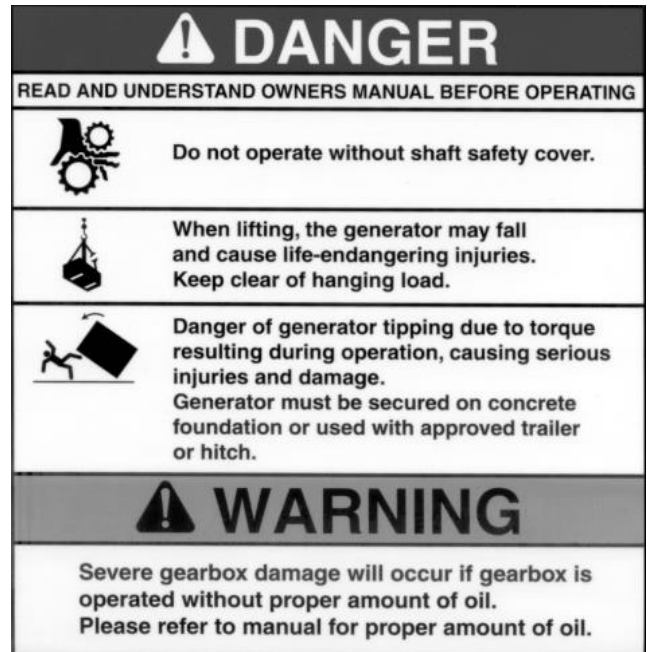
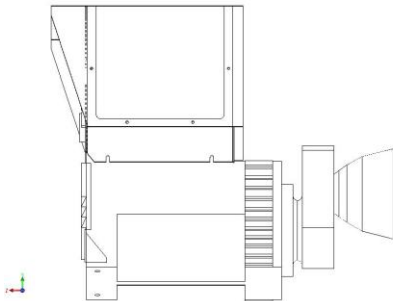
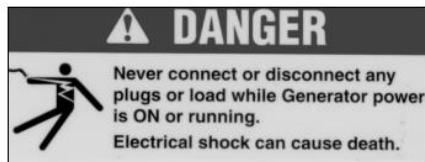
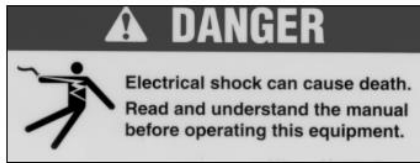

### Mechanical danger



- Operate the generator and tractor only when all protective devices have been installed properly and correctly.
- Before starting up the tractor, make sure that no one is standing in close proximity to the tractor or generator, particularly children.
- Watch out for children in particular because they tend to be attracted to machinery in operation.



Read and understand the operating instructions from the tractor manufacturer.

The power take-off shaft (PTO) represents extreme danger. Fatal injuries may result if protective devices are not used properly and at all times.

- Never stand near the PTO shaft while it is in operation.
- Always make sure that all safety devices are correctly in place.

- Replace any damaged safety devices immediately and do not operate the equipment until such replacement is made.
- The PTO shaft safety guard must be able to rotate freely.
- Always wear close-fitting clothing, and tie back long hair.
- Avoid any contact of your hair or clothing with the rotating PTO shaft.
- Switch off the tractor engine and wait until all moving parts are stationary before performing maintenance or adjustment work on the generator or the PTO shaft.



Read the operating instructions from the PTO shaft manufacturer.

The PTO shaft which connects the tractor and the generator transmits torque to the generator during normal operation. The generator can tip over, causing serious personal injury and damage. And therefore the generator must be secured on a concrete foundation or device approved in writing by IMD LLC.

### **Danger from exhaust fumes**

Tractor engines emit poisonous carbon monoxide gas through their exhaust systems. Carbon monoxide gas, if breathed in by a human in sufficient concentrations, can very rapidly lead to unconsciousness and death.

- Never operate the tractor inside any barn or other enclosed area where exhaust fumes might accumulate and endanger people or possibly farm animals.
- Operate the tractor only in open areas where sufficient ventilation is available.

### **Danger from electrical power**

- Extremely high and dangerous voltage is present at the power terminals.
- Contact with power terminals will result in extremely dangerous - possibly lethal - electric shock.
- Do not open the cover and touch the modular connector receptacle when the generator is in operation or switched on.
- Use extreme caution!
- Avoid contact with power terminals.
- Never handle any kind of electrical device while standing in water, while barefoot, or while hands or feet are wet. Dangerous electric shock causing severe personal injuries or death can result.



- Never permit any unqualified person to install, operate or service this equipment. Authorized and trained personnel only!

The installation and use of this generator must comply with all applicable codes and local, state and federal laws.

- Make sure to comply with the National Electric Code (NEC), Occupational Safety and Health Administration (OSHA) regulations, local industrial codes and local inspection requirements.
- Have a competent, qualified and licensed electrician who is familiar with applicable codes and laws pertaining to such equipment install and connect the generator.
- Electrical wiring used with this and related equipment must be in good condition, have approved insulation qualities, be properly supported and be of the correct wire gauge to handle the maximum anticipated load current as set forth in the technical specifications.
- 



Always verify that the generator is properly grounded before use.



## **WARNING**

In case of accident caused by electric shock, shut down the source of electrical power at once.

If you cannot do this, free the victim from the live conductor, but **AVOID DIRECT CONTACT WITH THE VICTIM.**

Use dry board, dry rope, or other non-conducting objects to free the victim from the live conductor.

If the victim is unconscious, first aid will be critically necessary.

Dial 911 immediately.

### **Danger from explosion**

- Do not smoke around the generator and tractor.
- Wipe up all fuel and oil spills immediately.
- Do not leave oily rags on the generator.
- Keep the area around the generator clean and free of debris at all times.

### **Preparing for use - Delivery conditions**

The power take-off generator is delivered fully assembled on a pallet.

Before using the generator for the first time, fill the gearbox with gear oil according to specifications (see page 24) and fit the guard for the PTO shaft according to the instructions of the PTO manufacturer.

- Before lifting or moving the PTO generator, secure it safely against falling.
- Do not stand immediately beside or beneath the suspended PTO generator.

### **Mounting onto a concrete slab**

*\*Two spacing bars are included with your 10KW PTO generator. These must be mounted underneath your generator to provide ground clearance for the PTO gearbox.*

The PTO shaft which connects the tractor and the generator transmits torque to the generator during normal operation.

Persons standing immediately beside the PTO generator may suffer serious personal injuries unless the generator is securely mounted onto a concrete slab per instructions on the following pages.

Serious damage may also be caused to the generator and the tractor, unless the generator is properly installed and all other safety precautions and operating instructions have been observed.

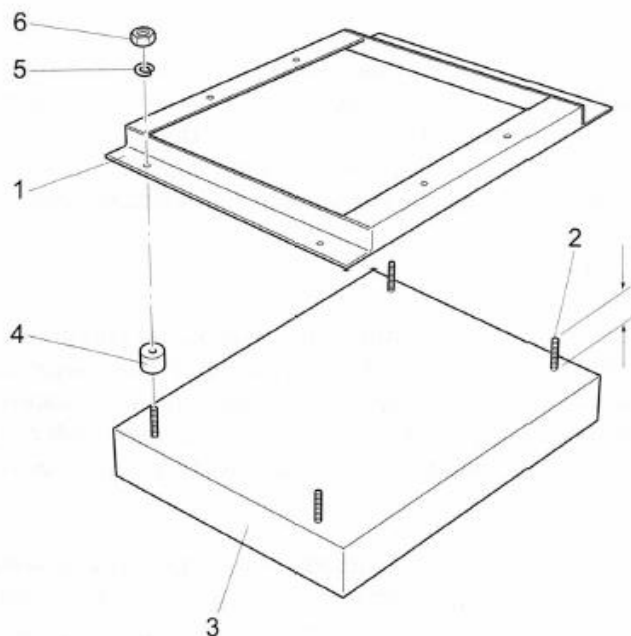

#### *Concrete slab construction*

1. PTO generator mounting base (base frame)
2. ½" masonry anchor bolt 8" long
3. Concrete slab
4. ½" thick rubber pad (will reduce vibration)
5. ½" lock washer
6. ½" nut

If the PTO is not mounted on a 3 point hitch or trailer: For safe operation the PTO generator must be mounted onto a concrete slab with dimensions set forth in diagram above.

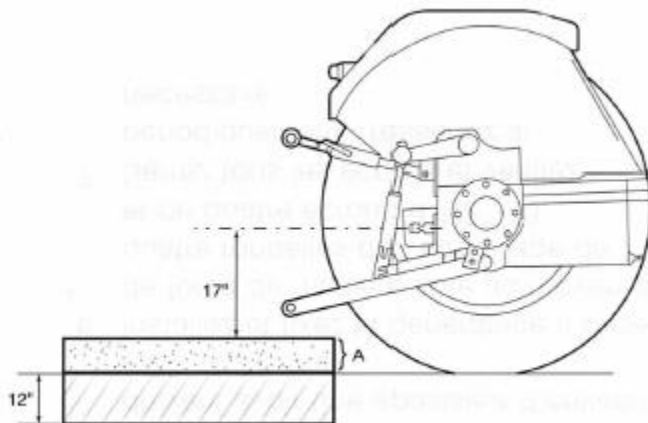

1. Choose a location and excavate the ground for a slab of the dimensions set forth in the diagram above. Excavate at least one foot = 12 inches (30.4 cm) deep and frame above ground sufficiently high enough that the height of the slab above the ground level is 17 inches (43.2 cm) below the centerline of the tractor's PTO shaft (see dimension A in the diagram above).
2. Reinforce with steel rods or steel grid or as otherwise recommended or required by local building codes or applicable laws, to increase the strength and stability of the concrete slab.
3. Pour the concrete and install four 1/2" x 8" masonry bolts according to the diagram above.
4. Let the concrete cure until the slab has fully dried.
5. Install thick rubber pads for the generator mounting base to rest on. The pads, which act as vibration absorbers, should be about 1/2" (1.27 cm) thick.
6. Install and secure PTO generator firmly using four 1/2" lock washers and four 1/2" – 13 nuts.
7. Tighten all nuts securely and check periodically and re-tighten as necessary.

### **Optional 3-point hitch**

A 3-point hitch frame can be ordered from IMD if the PTO generator needs to be moved frequently. This hitch frame will be connected to the tractor's three-point hydraulic system (see Accessories section page 27).

The hitch will be shipped disassembled. Basic tools are required for assembly.

Mounting the unit on the hitch frame and using the three-point attachment to the tractor hydraulics makes the PTO generator secure against tipping over during power generation, and yet allows it to be moved easily.

### **Optional Heavy Duty Trailer**

Using an IMD trailer is another option for increasing the stability and mobility of the PTO generator (see Accessories section page 27).

Mounting the PTO generator on the trailer will give it sufficient stability so that it does not tip over during service and also allows it to be easily moved from one location to another. The trailer will be shipped disassembled. Basic tools are required for assembly.

#### **⚠ CAUTION**

Only use an IMD trailer or 3-point hitch that is specifically designed for mounting your particular generator set, or the generator may tip during operation.

### **Electrical Installation**

#### **⚠ DANGER**

The generator is powerful enough to deliver a fatal electric shock. Extreme caution is required.

- All work on the power circuit and the electrical components must be carried out by an experienced and licensed electrician.
- Use only cables of the correct length, wire gauge and insulation depending on the specific application.
- Do not connect this generator to the electrical circuits of any house or building unless an isolation switch has been installed by a licensed electrician according to the manufacturer's specifications and all applicable building codes and other laws and regulations.

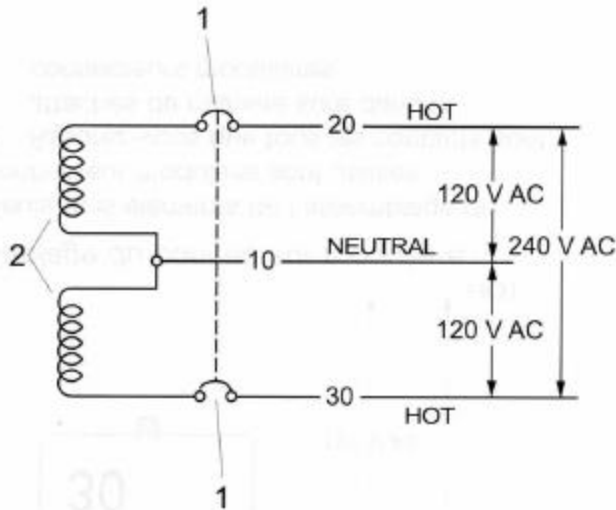

*Generator 3 wire AC Diagram*

1. Main circuit breaker
2. Dual stator AC power windings

The generator employs a stator assembly having a dual set of AC power windings and a 3-wire AC connection system. Each stator AC power winding supplies 120 volts AC. When the two windings are connected in series, a 240 volt AC output results.

### Grounding the generator



Make sure that the generator is properly grounded at all times!

Proper grounding of the generator will help prevent electric shock in the event of a ground fault condition in the generator or in electrical devices connected to the generator.

Proper grounding also helps to dissipate static electricity, which often builds up in ungrounded devices.

### **⚠ DANGER**

- Do not connect the ground wire to any pipe that carries flammable or explosive substances. Fire or an explosion may result.
- The National Electrical Code requires that the frame and external electrically conductive parts of this generator be properly connected to an approved earth ground.
- Local electrical codes may also require proper grounding of generator.
- However, local codes may vary widely. Consult with a local licensed and experienced electrician for grounding requirements in your area.

## Installing PTO shaft

If the guard for the power take-off shaft is not factory installed when the generator is shipped:

- The PTO shaft guard must be properly attached to the generator gearbox before the generator is started up.
- The PTO shaft end from the gearbox has a diameter of 1-3/8 inch and a 6-spline fitting (6-spline drive shaft).
- Push the PTO shaft onto the PTO shaft ends of the gearbox and tractor respectively, and engage.

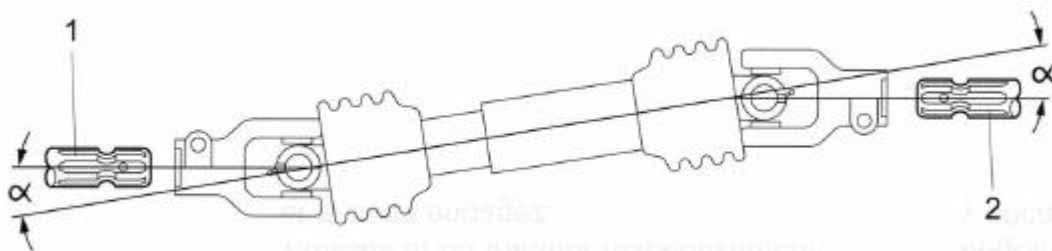

1 Generator PTO shaft end

2 Tractor PTO shaft end

α PTO shaft joint angles

- Keep generator PTO shaft end (1) and tractor PTO shafts (2) parallel as viewed from above and from the sides of the shafts.
- Maintain PTO shaft joint angles α equal and as small as possible.

## Checking the gearbox, oil level inspection

- Be sure the gearbox is filled with the correct amount of gear oil before the generator is used for the first time (see the “Maintenance section” for instructions).

## **Operation**

### **Switching ON**

Check the following every time before use:

- Is the generator securely attached to its concrete foundation or an approved device?
- Is the generator properly grounded?
- Are all safety devices fitted correctly?
- Is the PTO shaft fitted correctly between the tractor and the generator?
- Is there enough oil in the gearbox?
- Have the power cords of all electrical loads been disconnected from the generator?

When operating stationary PTO-driven equipment, always apply the tractor parking brake, and block the rear wheels on both sides in front and back with wedges or other appropriate objects.

### **Starting the generator**

#### **WARNING**

- Never start the generator with the main circuit breaker set to ON or closed position.
- Plug in the desired electrical loads.
  - This may be done in the following ways:
    1. Connect power cord set to the 120 Volt, 20 amp receptacles.
    2. Connect power cord set to the 120/240 Volt, 50 amp receptacles.

Only run the generator at a PTO shaft speed of 540 rpm. Higher PTO shaft speeds will damage the generator and may cause personal injury.

- Start the tractor.
- Set the PTO shaft lever to 540 rpm.

Only close circuit (turn breaker ON), when the panel frequency meter indicates 60 Hz. If the frequency or the voltage is too low or high, adjust speed accordingly.

- The correct operating frequency is 60 Hz.
- Switch the main circuit breaker to ON or to the closed position.
- Switch ON the electrical loads (e.g. appliances).

The generator supplies its power to the electrical loads.

- Check the frequency and/or Volt reading.

If the frequency and/or voltage have fallen below their correct operating range:

- CAREFULLY Increase the tractor engine speed until the Hz meter indicates correct range again.

### **Switching OFF**

- Turn OFF the electrical loads (appliances).
- Set the generator Main Circuit Breaker to the OFF or OPEN position.
- Let the generator and tractor engine run for a few minutes at no-load, to cool internal parts.
- Set the PTO shaft lever in the tractor to OFF.
- Wait until the PTO shaft and generator have stopped moving and are stationary.
- Switch off the tractor.
- Disconnect and remove the PTO shaft.
- Electrical connections can now be unplugged.

### **Maintenance, Cleaning, Care**

Regular maintenance and cleaning are crucial for optimum performance and safe operation of the generator.

Before starting maintenance and cleaning work:

- Switch the main circuit breaker to OFF or to the opened position.
- Disconnect and remove the PTO shaft

On completion of maintenance work:

- Re-install all safety devices correctly



## **Visual Inspection**

Before switching on:

- Check all components of the unit for visible external damage or leakage.
- Check all electrical cables for loose contacts, broken insulations or signs of scorching

## **Functional test**



After standing idle for long periods of time, the generator winding may corrode, reducing the efficiency.

It is necessary to run the system regularly to ensure that the PTO generator will still function properly in case of an emergency.

- A monthly functional test is recommended for damp conditions.
- A quarterly functional test is sufficient for dry conditions.

Regular operation of the system avoids:

1. Deterioration of the insulation resistance.
2. Build-up of deposits on the winding.
3. Corrosion.
4. Loss of performance.

## **Keeping the generator clean**



The generator housing has openings for ventilation purposes. If dirt clogs these ventilation openings the generator might overheat, get damaged and even catch fire. Dirt particles on the hot surface of the generator might catch fire.

For these reasons the following precautions should be taken:

- Keep the generator clean and free of foreign materials and objects.
- In dustier environments frequent cleaning, even daily cleaning, may be necessary.
- Remove dirt with compressed air (do not blow the dirt inside the generator) or a brush.

## ▲ CAUTION

Do not hose down the generator with water. Water can penetrate the generator stator and rotor windings, which could reduce insulation resistance. Possible generator failure may result.

- Clean the interior of the generator control panel in extreme harsh environmental conditions.
- The voltage regulator and electrical terminals especially must be kept clean.
- Check voltage regulator wires.
- Make sure all circuit boards are fully plugged in to their receptacles.

## ▲ CAUTION

Dirt and other deposits may form in loose connections and cause resistance and lack of conductivity. These conditions, if not corrected by regular cleaning, may lead to a short circuit and equipment failure.

### Changing the gear oil

The generator is shipped from the factory without oil in the gearbox. It is therefore necessary for the gearbox to be filled with the proper amount of gear oil:

### 27 ounces SAE90 gear oil

Drain the gear oil after the first 25 hours of use and refill with fresh oil as specified. Then change after every 250 hours of use or every six months, whichever is earlier. After each oil change, check that the correct amount of oil has been poured into the gearbox.\*\*

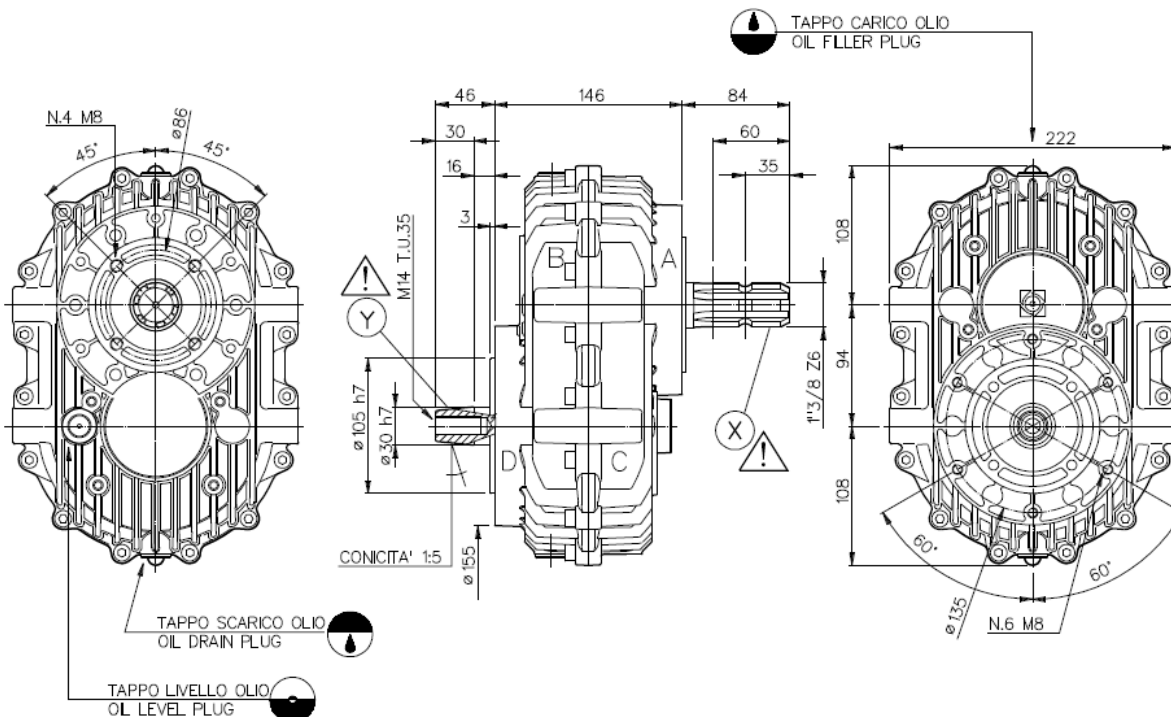

Check Oil every 8 hrs: Oil level is correct if the lower edge of the inspection hole is nearly covered with oil. **\*\*If your gearbox differs from the one above, contact IMD.**

**Long-term storage**

If the PTO generator is not used for a long period of time, do NOT store it outside or leave it exposed to the elements.

The PTO generator should be stored in a dry clean environment protected from dust (e.g. warehouse).



Observe the directions given for storage, because the air in barns may contain high levels of moisture or high concentrations of dust, or sometimes aggressive gases (e.g. ammonia). These factors result in an increased soiling of the generator and can lead to corrosion on the alternator winding.

- Before storing the PTO generator clean it thoroughly (see chapter Keeping the generator clean).
- For dust protection cover the PTO generator with a tarp while stored.
- In order to keep the generator ready for emergency use, please make regular operation checks (see chapter Functional Test).

**Maintenance schedule**

|                 | Inspection points                              | Every 8 hours or daily | After first 25 hours of use | Monthly | Quarterly | Every 250 hours or semi-annually | Note |
|-----------------|--|------------------------|-----------------------------|---------|-----------|----------------------------------|------|
| Generator       | Clean intake side.                             | ●                      |                             |         |           |                                  |      |
|                 | Clean discharge side.                          | ●                      |                             |         |           |                                  |      |
|                 | Clean front grid.                              | ●                      |                             |         |           |                                  |      |
|                 | Check that all connections are tight.          | ●                      |                             |         |           |                                  |      |
|                 | Check cables and plugs for defects and cracks. | ●                      |                             |         |           |                                  |      |
| Gearbox         | Check gear oil level                           | ●                      |                             |         |           |                                  |      |
|                 | Change gear oil.                               |                        | ●                           |         |           | ●                                |      |
| PTO shaft       | Lubricate.                                     | ●                      |                             |         |           |                                  |      |
| Functional test | Run generator.                                 |                        |                             | ■       | ◆         |                                  |      |

Please refer to operating instructions from the PTO shaft manufacturer  
 ■ Under damp conditions  
 ◆ Under dry conditions

## Technical specifications

|                                     |   |
|-------------------------------------|---|
| Generator                           | PTO 10-2S Spec 10011-10012                                    |
| Rated Maximum Cont. Wattage         | 10,000 watts  |
| Power Factor                        | 1   |
| Rated AC Volts                      | 120/240 V   |
| Rated Maximum Load Current          | 80/40 A   |
| Rated Frequency                     | 60 Hz   |
| PTO Power Needed (for rated output) | 20 HP   |
| PTO Drive Speed                     | 540 RPM   |
| PTO Shaft                           | 1-3/8", 6-spline  |
| Gearbox Reduction Type              | Single stage  |
| Gearbox Ration                      | 1 to 6.66   |
| Gearbox Oil                         | 27 oz SAE 90  |
| Approx. weight                      | 156 lbs   |
| Approx. dimensions l x w x h        | 26 x 9 x 16 inch  |
| Receptacles                         | -Nema 14-50 R (120/240V 50A)<br>-Nema 5-20R duplex (120V 20A) |
| Circuit Breaker                     | -40 amps 2-pole<br>-20 amps 1-pole                            |

## Exploded view, alternator

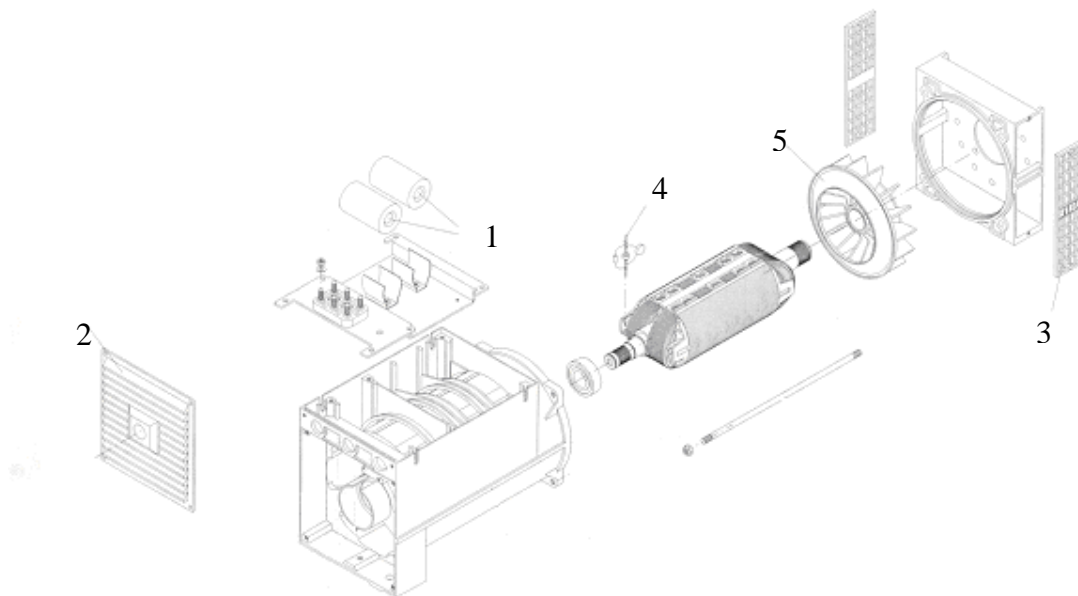

- |    |                           |         |
|----|---------------------------|---------|
| 1. | Capacitor 25mF 450V (2pc) | E140096 |
| 2. | Rear grid                 | P000069 |
| 3. | Front grid (2pc)          | E130854 |
| 4. | Electronic Kit            | P130856 |
| 5. | Fan (30mm)                | E130855 |

OR AVR BOARD (see below)

**Units with AVR:**

- |               |         |
|---------------|---------|
| -AVR Board    | E140065 |
| -Fuse for AVR | E140066 |

**Circuit Diagram**

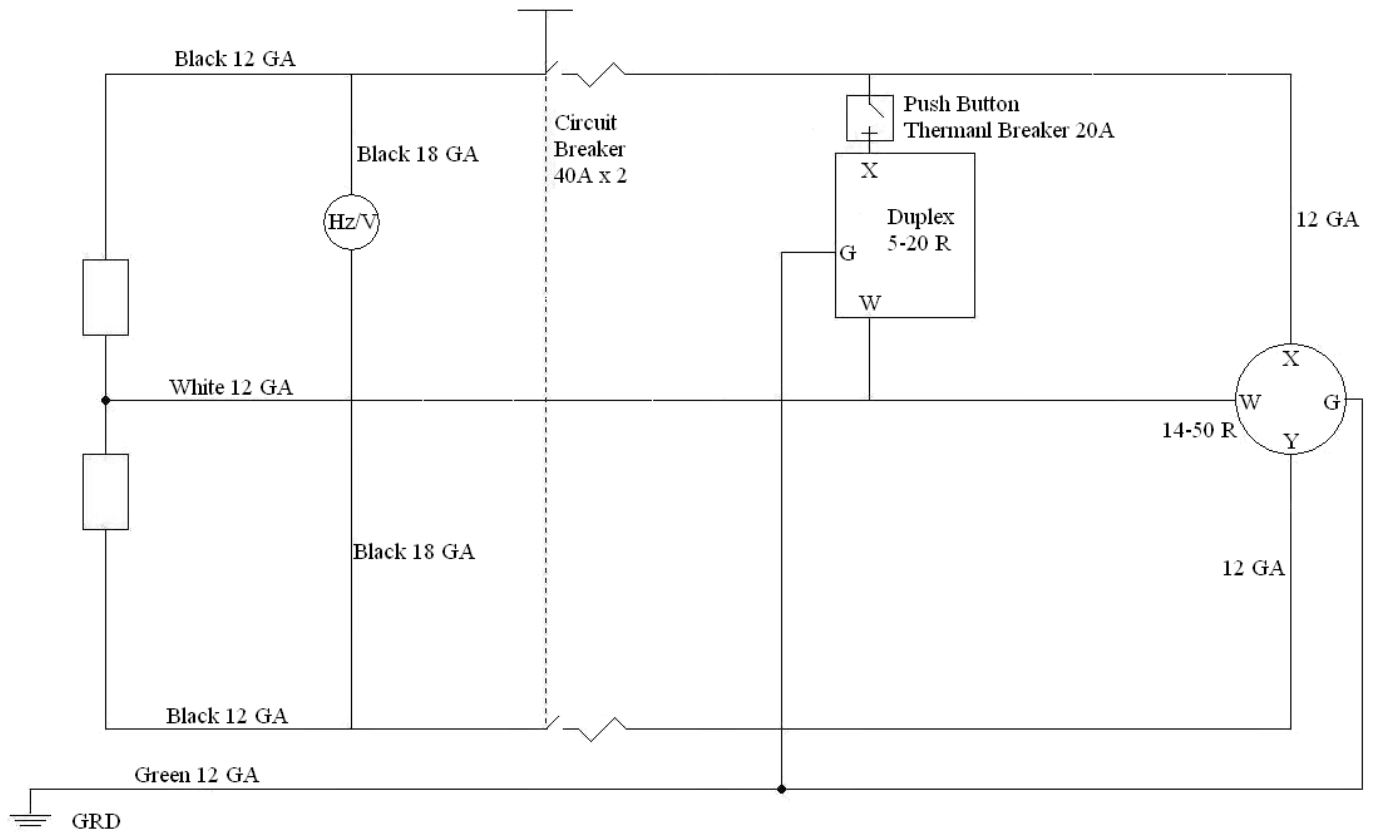

**Parts list Panel (Internal)**

|                             |         |
|-----------------------------|---------|
| Magnetic breaker 2-Pole 40A | E140076 |
| Thermal breaker 1-Pole 20A  | P000044 |
| Nema 14-50R                 | E140005 |
| Nema 5-20R duplex           | E140006 |
| Powermeter Pro              | E140131 |

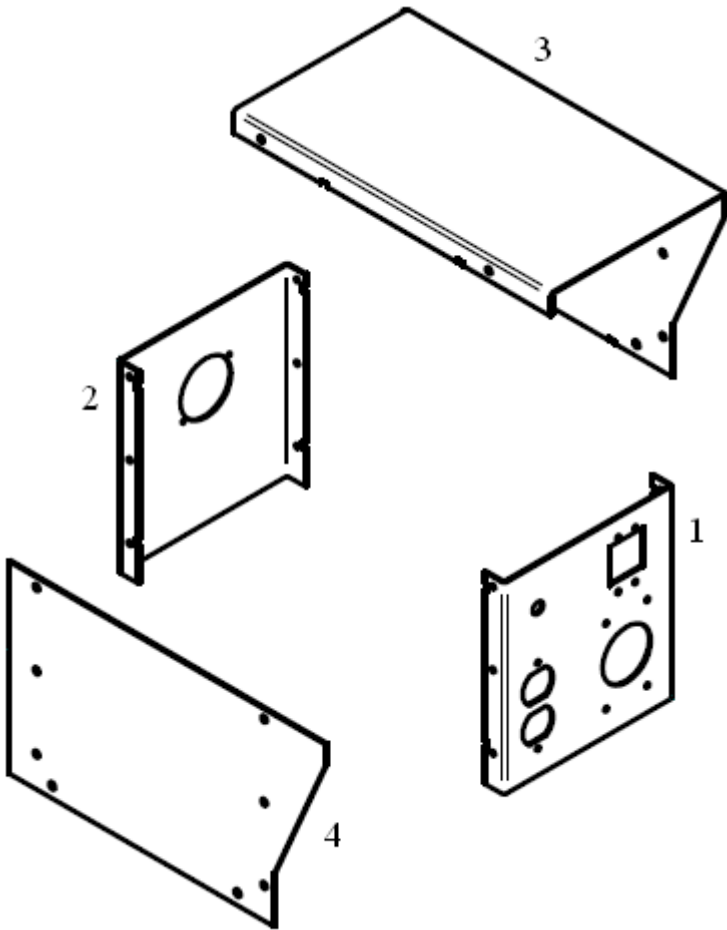
**Explosion, Panel View****Parts list Panel (External)**

|    |                              |         |
|----|------------------------------|---------|
| 1. | Facial PTO 10-2S, Spec 10011 | E140121 |
| 2. | Rear panel Spec 10011        | E140122 |
| 3. | Top housing Spec 10011       | E140123 |
| 4. | Side housing Spec 10011      | E140124 |

## Accessories

|   |        |
|---|--------|
| Drive Line up to 26KW, 1 3/8" – 6spline, 540RPM           | P10013 |
| 3 point hitch kit fits Category 1 and 2 tractor           | P10015 |
| Heavy duty trailer kit (off Hwy) fits Cat 1 and 2 tractor | P10016 |

### **Electrical:**

|   |         |
|---|---------|
| Full Power Plug 250V, 50A               | P1450   |
| External Powermeter (Volt/Hz LED meter) | P140142 |

## Terminology

Automatic Voltage Regulator (AVR) - Regulates the voltage of the unit to +/- 1% of the generators stated output. AVR boards are used in place of standard capacitor regulation for more efficient power.

Frequency (Hz) - The number of times an electrical signal repeats itself within a given time limit, usually defined in Hertz (Hz). The standard rating in the United States is 60 Hz.

Kilowatt (KW) - A standardized term used to describe to generators size in electrical output.

Load - The amount of electricity used.

Powermeter and Powermeter PRO - Are our specially designed power meters. Each meter is engineered to be vibration resistant and show the constant frequency and voltage of the unit. The Powermeter PRO comes with the extra LED indicator for measuring the percentage of power in use.

Power Take Off (PTO) - A power take-off (PTO) is a splined driveshaft, usually on a tractor used to provide power to separate attachments. The PTO allows for the use of a tractors engine for many different utilities.

Voltage - A measure of electrical potential, commonly 120v or 240v in the United States.

## Troubleshooting - \*For Authorized Service Only

| Problem   | Possible Fault  | Correction  |
|---|---|---|
| PTO shaft turns, but alternator does not.             | <ol style="list-style-type: none"> <li>1. Damaged gearbox.</li> <li>2. Broken Tapered Shaft.</li> <li>3. Broken Rotor shaft</li> </ol>  | <ol style="list-style-type: none"> <li>1. Replace Gearbox</li> <li>2. Call IMD LLC</li> <li>3. Call IMD LLC</li> </ol>  |
| Alternator Does not excite                            | <ol style="list-style-type: none"> <li>1. Demagnetized machine</li> <li>2. Reduced speed</li> <li>3. Faulty rotating diodes</li> <li>4. Failure in the winding</li> <li>5. Faulty capacitor (<b>AVR board</b>)</li> </ol> | <ol style="list-style-type: none"> <li>1. Apply to terminals a DC voltage between 6-12V for max. 1 second (<b>Only Capacitor regulated.</b>)</li> <li>2. Check speed and bring to the rated value</li> <li>3. Check and replace</li> <li>4. Check the winding resistance</li> <li>5. Check and replace<br/>2pc 25MF450V<br/>(<b>AVR Board</b>)</li> </ol> |
| Low no-load voltage                                   | <ol style="list-style-type: none"> <li>1. Reduced Speed</li> <li>2. Faulty rotating diodes</li> <li>3. Wrong capacitor value (<b>AVR settings</b>)</li> <li>4. Faulty windings</li> </ol>                                 | <ol style="list-style-type: none"> <li>1. Check speed and regulate</li> <li>2. Check and replace</li> <li>3. Check and replace<br/>2pc 25MF450V<br/>(<b>AVR board</b>)</li> <li>4. Check the winding resistance</li> </ol>  |
| High no-load voltage                                  | <ol style="list-style-type: none"> <li>1. Excessive motor Speed</li> <li>2. Wrong capacitor value (<b>AVR settings</b>)</li> </ol>  | <ol style="list-style-type: none"> <li>1. Check speed and regulate</li> <li>2. Check and replace<br/>2pc 25MF450V<br/>(<b>AVR board</b>)</li> </ol>   |
| Correct no-load voltage and too low full-load voltage | <ol style="list-style-type: none"> <li>1. Overload</li> <li>2. Engine speed slows down</li> <li>3. Faulty rotating diodes</li> </ol>  | <ol style="list-style-type: none"> <li>1. Check the load current</li> <li>2. Check motor capacity</li> <li>3. Check and replace</li> </ol>  |
| Unstable Voltage                                      | <ol style="list-style-type: none"> <li>1. Loose connections</li> <li>2. Irregular rotation</li> </ol>   | <ol style="list-style-type: none"> <li>1. Check connections</li> <li>2. Verify the rotation uniformity</li> </ol>   |
| Machine Overheating                                   | <ol style="list-style-type: none"> <li>1. Partially obstructed ventilation openings</li> <li>2. Probable overload</li> </ol>  | <ol style="list-style-type: none"> <li>1. Remove and clean the air inlet and outlet grids</li> <li>2. Check the load</li> </ol>   |
| Noisy machine   | <ol style="list-style-type: none"> <li>1. Damaged shaft or gearbox</li> <li>2. Faulty bearings</li> </ol>   | <ol style="list-style-type: none"> <li>1. Check mechanical connection and gearbox</li> <li>2. Check and replace</li> </ol>  |

## Spare Parts:



To obtain spare parts for your PTO generator, please contact your IMD dealer or to find a dealer in your area, please call 1.864. 968.0858. [www.imdllc.com](http://www.imdllc.com)  
To enable us to help you quickly, please provide the model and serial number for your PTO generator.