

STANDBY GENERATOR

150 kW

LIQUID-COOLED GENERATOR SET

Standby Power Rating

Model HT150 - 150 kW 60Hz



*Built in the USA using domestic and foreign parts

INCLUDES

- Two Line LCD Tri-lingual Digital Sync™ Controller
- Electronic Governor
- Closed Coolant Recovery System
- Flexible Fuel Line Connector
- UV/OzoneResistant Hoses
- Mobile Link™ Cellular Monitoring System*
- Sound Attenuated Aluminum Enclosure
- CA/MA Emissions Compliant
- Natural Gas or LP Gas Operation
- 2 Year Limited Warranty
- UL 2200 Listed

* Download the free Mobile Link App at



FEATURES

- **INNOVATIVE DESIGN & PROTOTYPE TESTING** are key components of our success in “IMPROVING POWER BY DESIGN.” But it doesn’t stop there. Total commitment to component testing, reliability testing, environmental testing, destruction and life testing, plus testing to applicable CSA, NEMA, EGSA, and other standards, allows you to choose Honeywell generators with the confidence that these systems will provide superior performance.
- **SOLID-STATE, FREQUENCY COMPENSATED VOLTAGE REGULATION** This state-of-the-art power maximizing regulation system is standard on all Honeywell models. It provides optimized FAST RESPONSE to changing load conditions and MAXIMUM MOTOR STARTING CAPABILITY by electronically torque-matching the surge loads to the engine. Digital voltage regulation at $\pm 1\%$.
- **SINGLE SOURCE SERVICE RESPONSE** from our extensive dealer network provides parts and service know-how for the entire unit, from the engine to the smallest electronic component.
- **Honeywell TRANSFER SWITCHES** The Honeywell generator line offers its own transfer systems and controls for total system compatibility.
- **TEST CRITERIA**
 - ◆ PROTOTYPE TESTED
 - ◆ SYSTEM TORSIONAL TESTED
 - ◆ NEMA MG1-22 EVALUATION
 - ◆ MOTOR STARTING ABILITY

150 kW

LIQUID-COOLED GENERATOR SET

Application & Engineering Data

GENERATOR SPECIFICATIONS

• Type	Synchronous
• Rotor Insulation	Class H
• Stator Insulation	Class H
• Telephone Interference Factor (TIF)	<50
• Alternator Output Leads Phase 3	6/4 wire
• Bearings	Sealed Ball
• Coupling	Gear Drive
• Load Capacity (Standby Rating)	150 kW
• Excitation System	Brushless

ENGINE SPECIFICATIONS

• Make	Generac
• Model	V-type
• Cylinders	10
• Displacement	6.8 Liter
• Bore	3.55
• Stroke	4.17
• Compression Ratio	9:1
• Intake Air System	Naturally Aspirated
• Lifter Type	Hydraulic

GOVERNOR SPECIFICATIONS

• Type	Electronic
• Frequency Regulation	Isochronous
• Steady State Regulation	± 0.25%

VOLTAGE REGULATION

• Type	Full Digital
• Sensing	Three Phase
• Regulation	± 0.25%

GENERATOR FEATURES

- Revolving field heavy duty generator
- Directly connected to the engine
- Operating temperature rise 120 °C above a 40 °C ambient
- Insulation is Class H rated at 130 °C rise
- All models are fully prototyped tested

ENGINE LUBRICATION SYSTEM

• Oil Pump	Gear
• Oil Filter	Full flow spin-on cartridge
• Crankcase	5 Quarts

ENGINE COOLING SYSTEM

• Type	Closed
• Water Pump	Belt driven
• Fan Speed	1670
• Fan Diameter	26 inches
• Fan Mode	Puller

FUEL SYSTEM

• Fuel Type	Natural gas, propane vapor
• Carburetor	Down Draft
• Secondary Fuel Regulator	Standard
• Fuel Shut Off Solenoid	Standard
• Operating Fuel Pressure	11" - 14" H ₂ O

ELECTRICAL SYSTEM

• Battery Charge Alternator	12V 30 Amp
• Static Battery Charger	12V, 2 Amp
• Recommended Battery	Group 24F, 12V, 525CCA
• System Voltage	12 Volts

ENCLOSURE FEATURES

- Aluminum all weather protective enclosure options available – Ensures protection against mother nature. Electrostatically applied textured epoxy paint for added durability.
- Enclosed critical grade muffler – Quiet, critical grade muffler is mounted inside the unit to prevent injuries.
- Small, compact, attractive – Makes for an easy, eye appealing installation.
- SAE – Sound attenuated enclosure ensures quiet operation.

Rating definitions - Standby: Applicable for supplying emergency power for the duration of the utility power outage. No overload capability is available for this rating. (All ratings in accordance with BS5514, ISO3046 and DIN6271). (All ratings in accordance with BS5514, ISO3046, ISO8528, SAE J1349 and DIN6271).

Operating Data

KW RATING (LP/NG)		150/150				
ENGINE SIZE		6.8 Liter V-10				
GENERATOR OUTPUT VOLTAGE/KW - 60Hz		kW LPG	AMP	kW Nat. Gas	AMP	CB Size (Both)
120/240V, 1-phase, 1.0 pf		150	600	136	567	700
120/208V, 3-phase, 0.8 pf		150	520	142	493	600
120/240V, 3-phase, 0.8 pf		150	451	142	427	500
277/480V, 3-phase, 0.8 pf		150	225	142	214	250
GENERATOR LOCKED ROTOR KVA AVAILABLE @ VOLTAGE DIP OF 35%						
Single phase or 208-240 3-phase		320				
480V 3-phase		350				
ENGINE FUEL CONSUMPTION (Natural Gas) (Propane)		Natural Gas (ft³/hr)		Propane (gal/hr.) (ft³/hr)		
Exercise cycle		155		1.7		
25% of rated load		556		6.09		
50% of rated load		1070		11.72		
75% of rated load		1491		16.33		
100% of rated load*		2061		22.57		
For Btu content, multiply ft ³ /hr x 2520 (LP) or ft ³ /hr x 1000 (NG)						
ENGINE COOLING						
Air flow (inlet air including alternator and combustion air)		ft ³ /min.		7,800		
System coolant capacity		US gal.		4.5		
Heat rejection to coolant		BTU/hr.		568,000		
Max. operating air temp. on radiator		°C (°F)		60 (150)		
Max. ambient temperature		°C (°F)		50 (140)		
COMBUSTION AIR REQUIREMENTS						
Flow at rated power 60 Hz		cfm		410		
SOUND EMISSIONS IN DBA						
Exercising at 7 meters				66		
Normal operation at 7 meters				79		
EXHAUST						
Exhaust flow at rated output 60 Hz		cfm		1,535		
Exhaust temp. at muffler outlet		°C (°F)		593 (1100)		
ENGINE PARAMETERS						
Rated synchronous RPM		60 Hz		3600		
POWER ADJUSTMENT FOR AMBIENT CONDIIONS						
Temperature Deration		3% for every 10 °C above - °C		25		
		1.65% for every 10 °F above - °F		77		
Altitude Deration		1% for every 100 m above - m		183		
		3% for every 1000 ft. above - ft.		600		

Refer to "Emissions Data Sheets" for maximum fuel flow for EPA and SCAQMD permitting purposes.

RATING: All three phases units are rated at 0.8 power factor. All single phase units are rated at 1.0 power factor. STANDBY RATING: Standby ratings apply to installations served by a reliable utility source. The standby rating is applicable to varying loads for the duration of a power outage. There is no overload capability for this rating. Ratings are in accordance with ISO-3046-1. Design and specifications are subject to change without notice.

150 kW

LIQUID-COOLED GENERATOR SETS

Interconnections

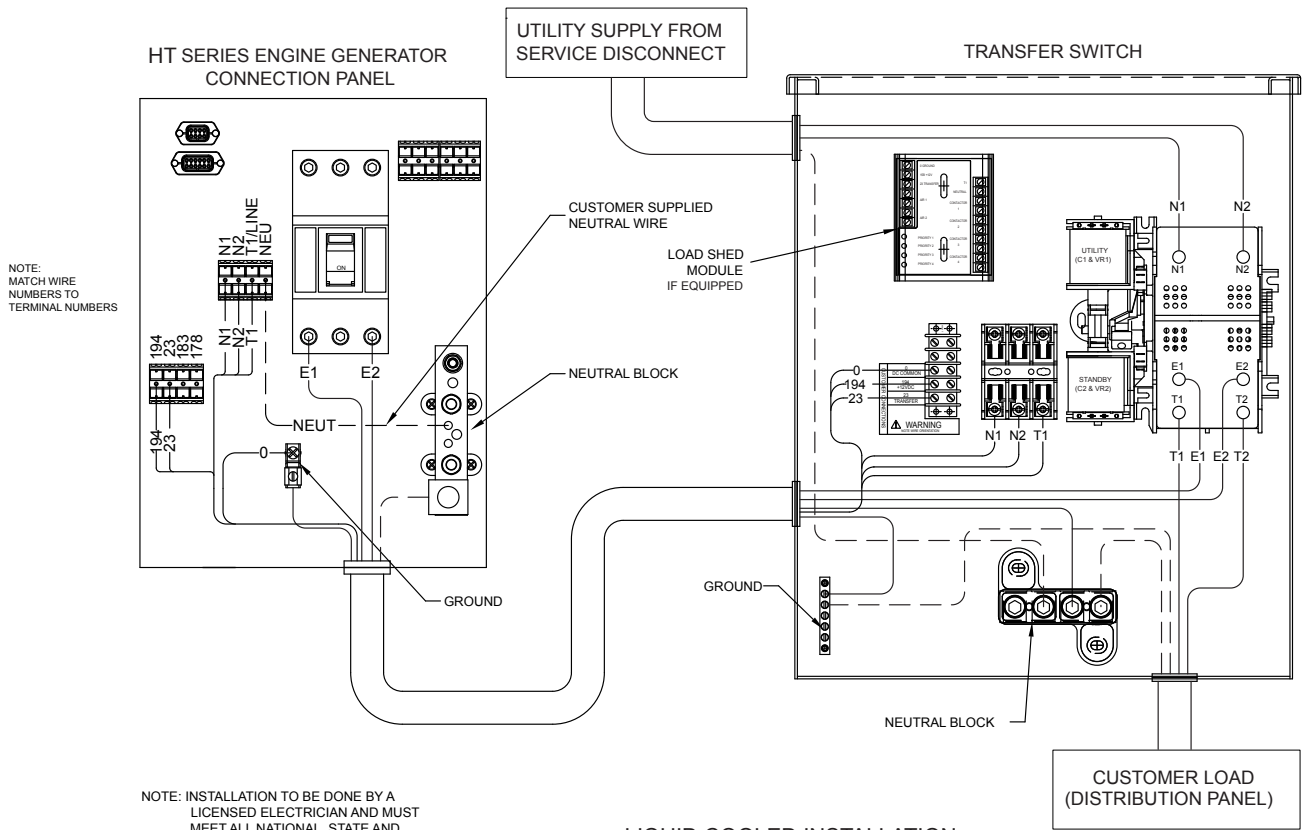

LIQUID COOLED INSTALLATION

CIRCUIT BREAKER WIRE AND CONDUIT SIZE				
kW	VOLTS	CB AMPS	LUG SIZE	
150	240 1 Ø	700	(3) 1/0 to 500 mcm	
150	240 3 Ø	500	(3) 2/0 to 400 mcm	
150	208 3 Ø	600	(3) 2/0 to 400 mcm	
150	480 3 Ø	250	(1) 600 mcm to #4 or (2) 250 mcm to 1/0	

CONTROL FEATURES

<ul style="list-style-type: none"> • 2-Line Plain Text LCD Display • Mode Switch <ul style="list-style-type: none"> -Auto -Off -Manual/Test (start) • Programmable start delay between 10-30 seconds • Engine Start Sequence • Engine Warm-up • Engine Cool-Down • Starter Lock-out • Smart Battery Charger • Automatic Voltage Regulation with Over and Under Voltage Protection 	<p>Simple user interface for ease of operation.</p> <p>Automatic Start on Utility failure. 7 day exerciser. Stops unit. Power is removed. Control and charger still operate.</p> <p>Start with starter control, unit stays on. If utility fails, transfer to load takes place.</p> <p>Standard</p> <p>Cyclic cranking: 16 sec. on, 7 rest (90 sec. maximum duration).</p> <p>5 seconds</p> <p>1 minute</p> <p>Starter cannot re-engage until 5 sec. after engine has stopped.</p> <p>Standard</p> <p>Standard</p>	<ul style="list-style-type: none"> • Automatic Low Oil Pressure Shutdown • Overspeed Shutdown • High Temperature Shutdown • Overcrank Protection • Safety Fused • Failure to Transfer Protection • Low Battery Protection • 50 Event Run Log • Future Set Capable Exerciser • Incorrect Wiring Protection • Internal Fault Protection • Common External Fault Capability • Governor Failure Protection 	<p>Standard</p> <p>Standard</p> <p>Standard</p> <p>Standard</p> <p>Standard</p> <p>Standard</p> <p>Standard</p> <p>Standard</p> <p>Standard</p> <p>Standard</p> <p>Standard</p> <p>Standard</p>
--	---	---	---

Single and three phase connections may vary, refer to the owner's manual for specific connection information.

Installation Layout

ENGINE/PAW	ENCLOSURE MATERIAL	WEIGHT DATA		NET LIFTING CAPACITY (CONCRETE) (KIB) (KLB)	NET LIFTING CAPACITY (STEEL) (KIB) (KLB)
		WEIGHT (KIB) (KLB)	HEIGHT (FT) (IN)		
6. BL. 100KW	ALUMINUM	1148 (2531)	79 (175)	1827 (4060)	1827 (4060)
6. BL. 150KW	ALUMINUM	1264 (2795)	79 (175)	1904 (4207)	1904 (4207)
6. BL. 150KW	ALUMINUM	1130 (2490)	79 (175)	1810 (3987)	1810 (3987)

NOTES:

- 1) MINIMUM RECOMMENDED CONCRETE PAD SIZE: 1240x48.8" WIDE X 3230 (127.2') LONG. REFERENCE INSTALLATION GUIDE SUPPLIED WITH UNIT FOR CONCRETE PAD GUIDELINES.
- 2) ALLOW SUFFICIENT ROOM ON ALL SIDES OF THE GENERATOR FOR MAINTENANCE AND SERVICING. THIS UNIT IS INSTALLED IN ACCORDANCE WITH CURRENT APPLICABLE SERVICE, LISTED, AND STANDARDS AS WELL AS FEDERAL, STATE AND LOCAL CODES FOR MINIMUM DISTANCES FROM OTHER STRUCTURES.
- 3) CIRCUIT BREAKER INFORMATION: SEE SPECIFICATION SHEET WITHIN OWNERS MANUAL.
- 4) INSIDE STUB-UP AREA FOR AC LOAD LEAD CONDUIT CONNECTION, NEUTRAL CONNECTION, BATTERY CHARGER 120 VOLT AC (5 AMP MAX.) CONNECTION, AND ACCESS TO TRANSFER SWITCH CONTROL WIRES. REMOVE FRONT COVER FOR ACCESS.
- 4A) FIELD CUT HOLE IS ONLY REQUIRED FOR MOUNTING OF GENERATOR ON AN EXISTING PAD.
- 5) REFERENCE OWNERS MANUAL FOR LIFTING WARNINGS.
- 6) REMOVE EITHER LEFT OR RIGHT HAND SIDE PANEL TO ACCESS EXHAUST MUFFLERS AND FAN BELT.

SERVICE ITEM ACCESSIBILITY CHART

SERVICE ITEM	ACCESS	
	100KW 6. BL.	150KW 6. BL.
DIEIL FILL CAP	THRU RIGHT FRONT DOOR	THRU LEFT FRONT DOOR
DIEIL DIP STICK	THRU LEFT FRONT DOOR	THRU LEFT FRONT DOOR
DIEIL FILTER	THRU LEFT FRONT DOOR	THRU LEFT FRONT DOOR
RADIATOR DRAIN HOSE	THRU LEFT FRONT DOOR	THRU LEFT FRONT DOOR
AIR CLEANER ELEMENT	THRU LEFT FRONT DOOR	THRU LEFT FRONT DOOR
SPARK PLUGS	EITHER FRONT DOORS	
MUFFLERS	BOTH FRONT DOORS	
FAN BELT	SEE NOTE 6	
BATTERY	SEE NOTE 6	
*GEARBOX FILL & DRAIN	THRU RIGHT REAR DOOR	THRU RIGHT REAR DOOR

*NOTE: EXCLUDING 6. BL. 150KW UNITS
REFERENCE OWNERS MANUAL FOR PERIODIC REPLACEMENT PART LISTINGS

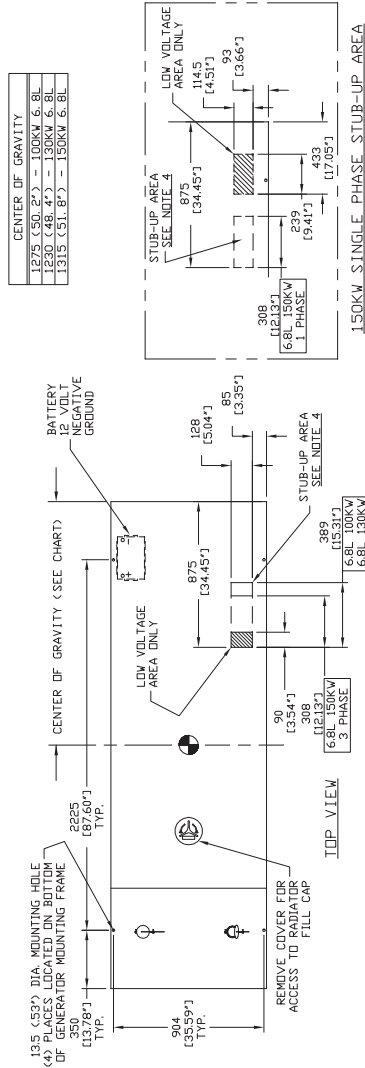

150KW SINGLE PHASE STUB-UP AREA

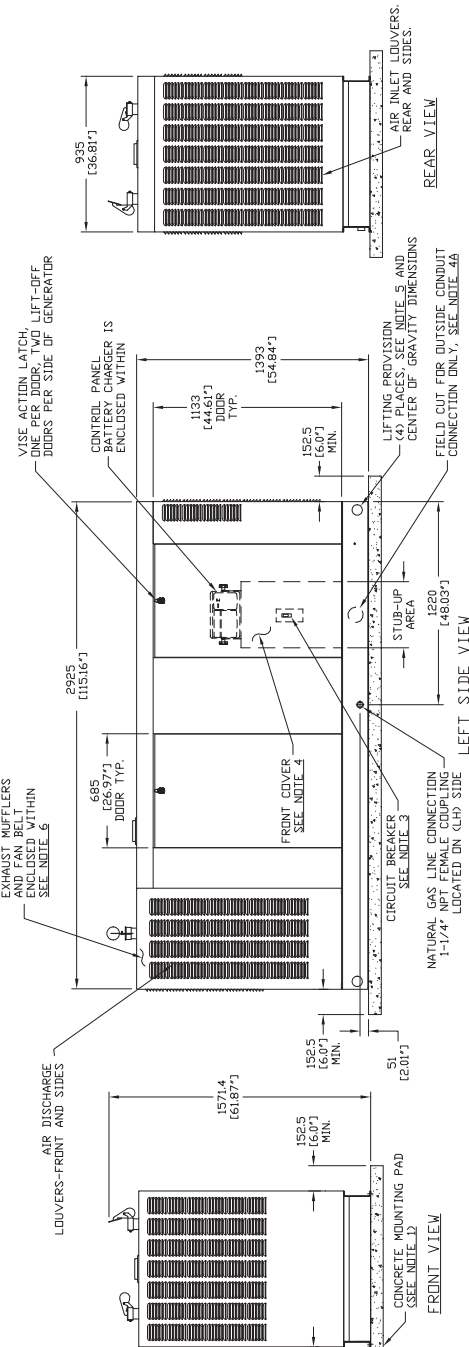

152.5 (6.07") MIN.
13.5 (532) DIA. MOUNTING HOLE (4) PLACES. 15.7 (172) DIA. RECOMMENDED MASONRY ANCHORS.

AVAILABLE ACCESSORIES

Model #	Product	Description
005632-0	Cold Weather Kit	If the temperature regularly falls below 32° F, install a cold weather kit to maintain optimal battery temperature. Kit consists of battery warmer with thermostat built into the wrap.
005667-0	Extreme Cold Weather Kit	Recommended where the temperature regularly falls below 32° F for extended periods of time. For liquid-cooled units only.
006160-0	Paint Kit	Industrial Grey
005660-0	Scheduled Maintenance Kit	The Liquid-Cooled Scheduled Maintenance Kits offer all the hardware necessary to perform a complete maintenance on Honeywell liquid-cooled generators.
006874-0	Smart Management Module (50 Amps)	Manage large loads by utilizing up to 8 individual Smart Management modules. These devices are installed directly in line with existing appliance wiring for easy installation.

Generac Power Systems, Inc.

S45 W29290 Hwy. 59

Waukesha, WI 53187

Tel: 1-855-GEN-INFO

honeywellgenerators.com

0191060SBY-F

May 2015

© Generac Power Systems, Inc. All rights reserved.
Specifications subject to change without notice.

The Honeywell Trademark is used under
license from Honeywell International Inc.

Honeywell International Inc. makes no representation
or warranties with respect to this product.

