



Owner's Manual
For
Automatic Transfer Switch

100 - 200 Amp, Service Entrance/Non-Service Entrance

Model Numbers

RTSW100A3

RTSC100A3

RTSW150A3

RTSW200A3

RTSC200A3

MODEL NUMBER: _____

SERIAL NUMBER: _____

DATE PURCHASED: _____

WWW.GENERAC.COM
888-436-3722

Para español , visita: <http://www.generac.com/service-support/product-support-lookup>

Pour le français, visiter : <http://www.generac.com/service-support/product-support-lookup>

SAVE THIS MANUAL FOR FUTURE REFERENCE

⚠ WARNING

California Proposition 65. This product contains or emits chemicals known to the state of California to cause cancer, birth defects, and other reproductive harm. (000005)

Table of Contents

Section 1 Safety

1.1 General	1
1.2 General Hazards	1

Section 2 General Information

2.1 Introduction	3
2.2 Unpacking	3
2.3 Equipment Description	3
2.3.1 Transfer Switch Mechanism	3
2.3.2 Utility Service Circuit Breaker (if equipped)	4
2.4 Transfer Switch Data Decal	4
2.5 Transfer Switch Enclosure	4
2.6 Safe Use of Transfer Switch	4
2.7 Load Management Options	4
2.7.1 Smart A/C Module	4
2.7.2 Smart Management Module (Optional)	5
2.7.3 Load Management Analysis	5

Section 3 Installation

3.1 Introduction to Installation	7
3.2 Mounting	7
3.3 Connecting Power Source and Load Lines .	7
3.4 Connecting Start Circuit Wires	7
3.5 Connecting Smart A/C Module	8
3.5.1 Control of Air Conditioner Load	8
3.6 Auxiliary Contacts	9

Section 4 Operation

4.1 Functional Tests and Adjustments	11
4.2 Manual Operation	11
4.2.1 Close to Utility Source Side	11
4.2.2 Close to Generator Source Side	11
4.2.3 Return to Utility Source Side	12
4.3 Voltage Checks	12
4.3.1 Utility Voltage Checks	12
4.3.2 Generator Voltage Checks	12
4.4 Generator Tests Under Load	12
4.5 Checking Automatic Operation	13
4.6 Installation Summary	13
4.7 Shutting Generator Down While Under Load	13
4.8 Testing The Smart A/C Module	13
4.9 Testing The Smart Management Module ..	14

Section 5 Drawings and Diagrams

5.1 Installation Drawing	15
5.1.1 No. 0G6832-A 100A SE & non-SE/150-200A non-SE	15
5.1.2 No. 0K2422-A 150/200A SE	16
5.2 Interconnection Drawing	18
5.2.1 No. 0L3240-A (Part 1 of 4) Liquid-cooled Generator	18
5.2.2 No. 0L3240-A (Part 2 of 4) Liquid-cooled Generator	19
5.2.3 No. 0L3240-A (Part 3 of 4) Air-cooled Generator	20
5.2.4 No. 0L3240-A (Part 4 of 4) Air-cooled Generator	21

This page intentionally left blank.

Section 1 Safety

1.1 — General

Read the following information carefully before attempting to install, operate or service this equipment. Also read the instructions and information on tags, decals, and labels that may be affixed to the transfer switch. Replace any decal or label that is no longer legible.



⚠️ WARNING

Consult Manual. Read and understand manual completely before using product. Failure to completely understand manual and product could result in death or serious injury. (000100a)

The manufacturer cannot anticipate every possible circumstance that might involve a hazard. The warnings in this manual, and on tags and decals affixed to the unit are not all-inclusive. If using a procedure, work method or operating technique the manufacturer does not specifically recommend, ensure that it is safe. Also make sure the procedure, work method or operating technique used does not render the transfer switch unsafe.

Throughout this publication, and on tags and decals affixed to the generator, **DANGER**, **WARNING**, **CAUTION** and **NOTE** blocks are used to alert personnel to special instructions about a particular operation that may be hazardous if performed incorrectly or carelessly. Observe them carefully. Their definitions are as follows:

⚠️ DANGER

Indicates a hazardous situation which, if not avoided, will result in death or serious injury.

(000001)

⚠️ WARNING

Indicates a hazardous situation which, if not avoided, could result in death or serious injury.

(000002)

⚠️ CAUTION

Indicates a hazardous situation which, if not avoided, could result in minor or moderate injury.

(000003)

NOTE:

Notes contain additional information important to a procedure and will be found within the regular text of this manual.

These safety warnings cannot eliminate the hazards that they indicate. Common sense and strict compliance with the special instructions while performing the action or service are essential to preventing accidents.

1.2 — General Hazards

- Any AC generator that is used for backup power if a NORMAL (UTILITY) power source failure occurs, must be isolated from the NORMAL (UTILITY) power source by means of an approved transfer switch. Failure to properly isolate the NORMAL and STANDBY power sources from each other may result in injury or death to electric utility workers, due to backfeed of electrical energy.
- Improper or unauthorized installation, operation, service or repair of the equipment is extremely dangerous and may result in death, serious personal injury, or damage to equipment and/or personal property.
- Extremely high power and dangerous voltages are present inside an installed transfer switch. Any contact with high voltage terminals, contacts or wires can result in LETHAL electric shock, while arc flash can cause blindness and severe burns. **DO NOT WORK ON THE TRANSFER SWITCH UNTIL ALL POWER SUPPLIES TO THE SWITCH HAVE BEEN POSITIVELY TURNED OFF.**
- Competent, qualified personnel should install, operate and service this equipment. Adhere strictly to local, state and national electrical and building codes. When using this equipment, comply with regulations the National Electrical Code (NEC), CSA Standard; C22.1 Canadian Electric Code and Occupational Safety and Health Administration (OSHA) have established.
- Never handle any kind of electrical device while standing in water, while barefoot, or while hands or feet are wet. **DANGEROUS ELECTRICAL SHOCK MAY RESULT.**
- Because jewelry conducts electricity, wearing it may cause dangerous electrical shock. Remove all jewelry (such as rings, watches, bracelets, etc.) before working on this equipment.
- If working on this equipment while standing on metal or concrete, place insulative mats over a dry wood platform. Work on this equipment only while standing on such insulative mats.
- Never work on this equipment while physically or mentally fatigued.

- Keep the transfer switch enclosure door closed and bolted at all times. Only qualified personnel should be permitted access to the switch interior.
- In case of an accident caused by electric shock, immediately shut down the source of electrical power. If this is not possible, attempt to free the victim from the live conductor but **AVOID DIRECT CONTACT WITH THE VICTIM**. Use a nonconducting implement, such as a dry rope or board, to free the victim from the live conductor. If the victim is unconscious, apply first aid and get immediate medical help.
- When an automatic transfer switch is installed for a standby generator set, the generator engine may crank and start at any time without warning. To avoid possible injury that might be caused by such sudden start-ups, the system's automatic start circuit must be disabled before working on or around the generator or transfer switch. Then place a "DO NOT OPERATE" tag on the transfer switch and on the generator.
- Any voltage measurements should be performed with a meter that meets UL3111 safety standards, and meets or exceeds overvoltage class CAT III.

Section 2 General Information

2.1 — Introduction

Thank you for purchasing a Generac transfer switch. This manual has been prepared especially for the purpose of familiarizing personnel with the design, application, installation, operation and servicing of the applicable equipment. Read this manual carefully and comply with all instructions. This will help to prevent accidents or damage to equipment that might otherwise be caused by carelessness, incorrect application, or improper procedures.

Every effort has been expended to make sure that the contents of this manual are both accurate and current. The manufacturer, however, reserves the right to change, alter or otherwise improve the product or manual at any time without prior notice.

2.2 — Unpacking

Carefully unpack the transfer switch. Inspect closely for any damage that might have occurred during shipment. The purchaser must file with the carrier any claims for loss or damage incurred while in transit.

Check that all packing material is completely removed from the switch prior to installation.

2.3 — Equipment Description

The automatic transfer switch is used for transferring electrical load from a UTILITY (NORMAL) power source to a GENERATOR (STANDBY) power source. Such a transfer of electrical loads occurs automatically when the UTILITY power source has failed or is substantially reduced and the GENERATOR source voltage and frequency have reached an acceptable level. The transfer switch prevents electrical feedback between two different power sources (such as the UTILITY and GENERATOR sources) and, for that reason, codes require it in all standby electric system installations.

The transfer switch consists of a transfer mechanism, utility service disconnect circuit breaker (if equipped), a control relay, a Smart A/C module, fuses, terminal strip, and fuse holder for connection of sensing wires.

This transfer switch is suitable for use as service equipment if equipped with utility service circuit breaker.

2.3.1— Transfer Switch Mechanism

These switches (Figure 2-1) are used with a single-phase system, when the single-phase NEUTRAL line is to be connected to a neutral lug and is not to be switched.

Solderless, screw-type terminal lugs are standard.

The conductor size range is as follows:

Switch Rating	Wire Range	Conductor Tightening Torque
100A	#14-1/0 AWG (Cu/Al)	50 in-lbs (5.6 Nm)
150/200A	#6-250 MCM (Cu/Al)	275 in-lbs (31 Nm)

This transfer switch is suitable for control of motors, electric discharge lamps, tungsten filament and electric heating equipment where the sum of motor full load ampere ratings and the ampere ratings of other loads do not exceed the ampere rating of the switch and the tungsten load does not exceed 30 percent of the switch rating.

This UL listed transfer switch is for use in optional standby systems only (NEC article 702).

A 100A rated switch is suitable for use on circuits capable of delivering not more than 10,000 RMS symmetrical amperes, 250 VAC maximum, when protected by a 100A maximum circuit breaker (Siemens types QP or BQ) or 150A maximum circuit breaker (Square D Q2, Westinghouse CA-CAH, General Electric TQ2 and Siemens QJ2).

A 200A rated switch is suitable for use on a circuit capable of 10,000 RMS symmetrical amperes, 240 VAC when protected by a circuit breaker without an adjustable short time response or by fuses.

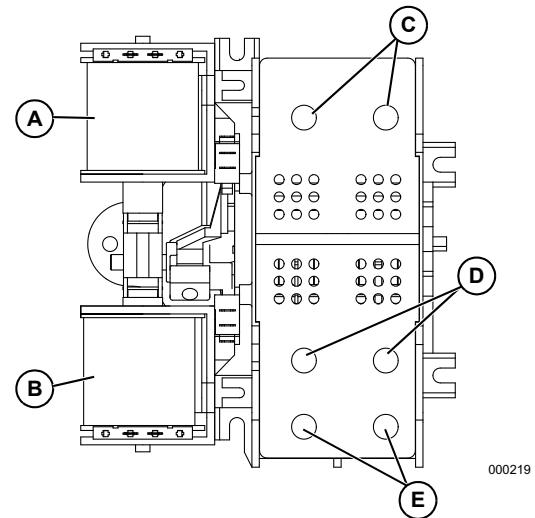

Figure 2-1. Typical Single-Phase ATS Transfer Mechanism

A	Utility Closing Coil
B	Generator Closing Coil
C	Utility Lugs (N1 & N2)
D	Generator Lugs (E1 & E2)
E	Load Lugs (T1 & T2)

2.3.2— Utility Service Circuit Breaker (if equipped)

The utility service and generator disconnect circuit breakers for 100 amp models are:

- Type BQ, 2-pole
- 120/240VAC, 100A
- 50/60 Hertz
- Wire range: #1 - #8 AWG (Cu/Al)
- The conductor tightening torque is 50 **in-lbs.** (5.6 Nm).

The utility service circuit breakers for 150/200 amp models are:

- Type 225AF, 2-pole
- 120/240VAC, 150A/200A
- 50/60 Hertz
- Wire range:
 - Line: 300 MCM - 6 STR (Cu/Al)
 - Load - ATS: 250 MCM - 6 STR (Cu/Al)
- The conductor tightening torque is:
 - Line: 375 **in-lbs** (42.4 Nm)
 - Load - ATS: 275 **in-lbs.** (31 Nm)

The utility service circuit breakers for Siemens 150/200 amp models are:

- Siemens, Type QN, 2-pole
- 120/240 VAC, 150/200A
- 50/60 Hertz
- Wire range:
 - Line: 300 MCM - 1 STR (Cu/Al)
 - Load - ATS: 250 MCM - 6 STR (Cu/Al)
- The conductor tightening torque is:
 - Line: 250 **in-lbs.** (28.2 Nm)
 - Load - ATS: 275 **in-lbs.** (31 Nm)

2.4 — Transfer Switch Data Decal

A data decal is permanently affixed to the transfer switch enclosure. Use this transfer switch only with the specific limits shown on the data decal and on other decals and labels that may be affixed to the switch. This will prevent damage to equipment and property.

When requesting information or ordering parts for this equipment, make sure to include all information from the data decal.

For future reference, record the Model and Serial numbers in the space provided on the front cover of this manual

2.5 — Transfer Switch Enclosure

The standard switch enclosure is a National Electrical Manufacturer's Association (NEMA) and UL 3R type. UL and NEMA 3R (indoor/outdoor rated) type enclosures primarily provide a degree of protection against falling rain and sleet; are undamaged by the formation of ice on the enclosure.

2.6 — Safe Use of Transfer Switch



⚠ WARNING

Consult Manual. Read and understand manual completely before using product. Failure to completely understand manual and product could result in death or serious injury. (000100a)

Before installing, operating or servicing this equipment, read the SAFETY RULES carefully. Comply strictly with all SAFETY RULES to prevent accidents and/or damage to the equipment. The manufacturer recommends that a copy of the SAFETY RULES be posted near the transfer switch. Also, be sure to read all instructions and information found on tags, labels and decals affixed to the equipment.

Two publications that outline the safe use of transfer switches are the following:

- NFPA 70; National Electrical Code
- UL 1008, STANDARD FOR SAFETY-AUTOMATIC TRANSFER SWITCHES

NOTE: It is essential to use the latest version of any standard to ensure correct and current information.

2.7 — Load Management Options

Load management systems are designed to work together to prevent a generator from being overloaded by large appliance loads. A Smart A/C Module is standard in these switches. An optional Smart Management Module is also available.

2.7.1— Smart A/C Module

Up to four air conditioner loads can be managed by the Smart A/C Module. The Smart A/C Module manages the loads by “shedding” the connected loads in the event of a drop in generator frequency (overload). Loads to be “shed” are in 4 priority levels on the module.

Priorities A/C 1-4 (A in Figure 2-2) have connections for an air conditioner. To control an air conditioner, no additional equipment is required. Internal normally closed relays interrupt the 24 VAC thermostat control signal to disable the air conditioner load.

Four LEDs, located on the Smart A/C Module (B in Figure 2-2), illuminate when a load is connected and powered.

The Smart A/C Module has a test button used to simulate an overload condition. This button operates even when the transfer signal is inactive.

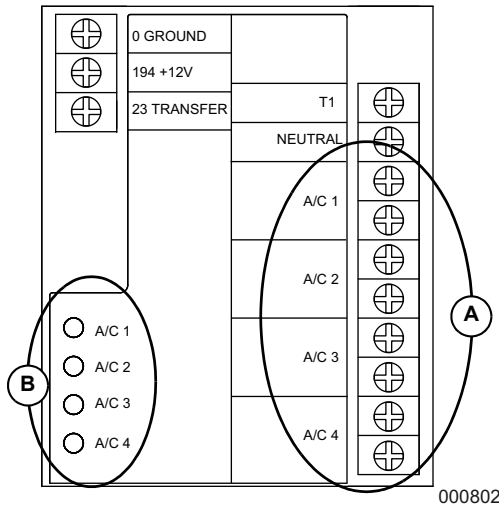

Figure 2-2. Smart A/C Module

2.7.2— Smart Management Module (Sold Separately)

Any loads, including central air conditioners, can be managed using a Smart Management Module (SMM). The system can accommodate up to eight individual SMM modules.

NOTE: The SMM modules are self-contained and have individual built-in controllers.

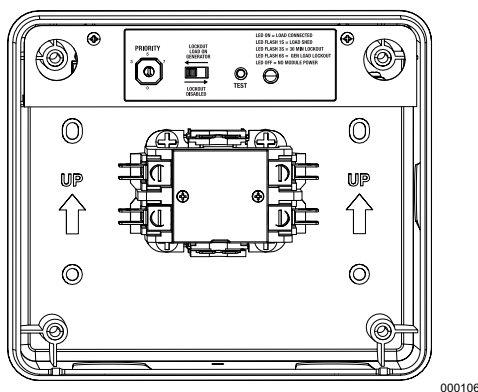

Figure 2-3. Smart Management Module

2.7.3— Application Considerations

Generator overload condition is determined by generator frequency. Loads are shed when frequency is less than 58 Hz for three seconds or less than 50 Hz for ½ second (for 60 Hz systems).

The Smart A/C Module can be used in conjunction with individual Smart Management Modules (SMM) to manage a combined total of eight loads.

- Use Priorities A/C 1-4 on the Smart A/C Module as the top priorities, then up to four Smart Management Modules as Priorities 5-8.
- Use only select A/C priorities on the Smart A/C Module as the top priorities, then use additional Smart Management Modules as the remaining priorities.
- A Smart Management Module can share a priority with an A/C priority on the Smart A/C Module provided the generator is sized to handle the combined surge load from both appliances. Sharing priorities can allow up to 12 loads to be managed in a properly sized system.

In any combination of modules, the recovery times after a loss of utility power or shutdown due to overload are shown in Table 1.

Table 1. Priority Settings

Priority	Recovery Time	Smart A/C Module	Smart Management Module
1	5 minutes	Yes	Yes
2	5 minutes 15 seconds	Yes	Yes
3	5 minutes 30 seconds	Yes	Yes
4	5 minutes 45 seconds	Yes	Yes
5	6 minutes	NA	Yes
6	6 minutes 15 seconds	NA	Yes
7	6 minutes 30 seconds	NA	Yes
8	6 minutes 45 seconds	NA	Yes

Refer to the SMM Owner’s/Installation Manual for detailed characteristics and specifications of that product.

This page intentionally left blank.

Section 3 Installation

3.1 — Introduction to Installation

This equipment has been wired and tested at the factory. Installing the switch includes the following procedures:

- Mounting the enclosure.
- Connecting power source and load leads.
- Connecting the generator start and sensing circuit.
- Connecting any auxiliary contact (if needed).
- Testing functions.

3.2 — Mounting

Mounting dimensions for the transfer switch enclosure are in this manual. Enclosures are typically wall-mounted. See the “Installation Diagram” section.

DANGER

Equipment malfunction. Installing a dirty or damaged transfer switch will cause equipment malfunction and will result in death or serious injury.

(000119)

This transfer switch is mounted in a UL type 3R enclosure. It can be mounted outside or inside and should be based on the layout of installation, convenience and proximity to the utility supply and load center.

Install the transfer switch as close as possible to the electrical loads that are to be connected to it. Mount the switch vertically to a rigid supporting structure. To prevent switch distortion, level all mounting points. If necessary, use washers behind mounting holes to level the unit.

3.3 — Connecting Power Source and Load Lines



DANGER

Electrocution. Turn utility and emergency power supplies to OFF before connecting power source and load lines. Failure to do so will result in death or serious injury.

(000116)

Installation and interconnection diagrams are provided in this manual.

NOTE: All installations must comply with national, state and local codes. It is the responsibility of the installer to perform an installation that will pass the final electrical inspection.

The utility supply connection is made at the utility service disconnect circuit breaker terminals. The generator and customer load connections are made at the transfer switch mechanism, inside the switch enclosure.

Conductor sizes must be adequate to handle the maximum current to which they will be subjected, based on the 75°C column of tables, charts, etc. used to size conductors. The installation must comply fully with all applicable codes, standards and regulations.

All power cables can enter the enclosure through the knockouts provided. If not using the knockouts, conduit entry into the enclosure above the level of uninsulated live parts shall use fittings listed for use in wet locations to maintain the Type 3R rating. Conduits should be arranged to provide separation between the Utility and Generator supply conductors inside the enclosure.

NOTE: If aluminum conductors are used, apply corrosion inhibitor to conductors. After tightening terminal lugs, carefully wipe away any excess corrosion inhibitor.

Tighten terminal lugs to the torque values as noted on the decal located on the inside of the door. After tightening terminal lugs, carefully wipe away any excess corrosion inhibitor.

CAUTION

Equipment damage. Verify all conductors are tightened to the factory specified torque value. Failure to do so could result in damage to the switch base.

(000120)

Connect power source and load conductors to clearly marked terminal lugs on transfer mechanism as follows:

1. Connect utility (normal) power source cables to utility service disconnect circuit breaker if equipped, or N1 and N2 lugs of the transfer switch. See Figure 2-1.
2. Connect the generator (standby) source power cables to transfer switch terminals E1, E2.
3. Connect customer LOAD leads to switch terminals T1, T2.

3.4 — Connecting Start Circuit Wires

Control system interconnections may consist of N1, N2, and T1, and leads 23 and 194. The generator control wiring is a Class 1 signaling circuit. Reference instruction manual of specific engine generator for wiring connection details. Recommended wire gauge sizes for this wiring depends on the length of the wire, as recommended in the following chart:

Maximum Wire Length	Recommended Wire Size
1-115 ft (1-35m)	No. 18 AWG.
116-185 ft (36-56m)	No. 16 AWG.
186-295 ft (57-89m)	No. 14 AWG.
296-460 ft (90-140m)	No. 12 AWG.

Exception: Conductors of AC and DC circuits, rated 1000 volts nominal, or less, shall be permitted to occupy the same equipment, cable, or conduit. All conductors shall have an insulation rating equal to at least the maximum circuit voltage applied to any conductor within the equipment, cable, or conduit. See NEC 300.3(C)(1).

3.5 — Connecting Smart A/C Module

The Smart A/C Module can control an air conditioner (24 VAC) directly. See Figure 3.1.

3.5.1— Control of Air Conditioner Load

1. Route the thermostat cable (from the furnace/thermostat to the outdoor air conditioner unit) to the transfer switch.
2. Connect the wire to the terminal strip terminals (A/C 1) on the Smart A/C Module as shown in Figure 3.1. These are normally closed contacts which open upon load shed conditions. Route thermostat wire away from high voltage wires.
3. If required, connect additional air conditioners to the terminal strip terminals (A/C 2-4).

Contact Ratings	
A/C 1-4	24 VAC, 1.0 Amp Max

NOTE: These instructions are for a typical air conditioner installation. Control of certain heat pumps and 2-stage air conditioners may require special connections or the use of Smart Management Modules (SMM) to control the loads.

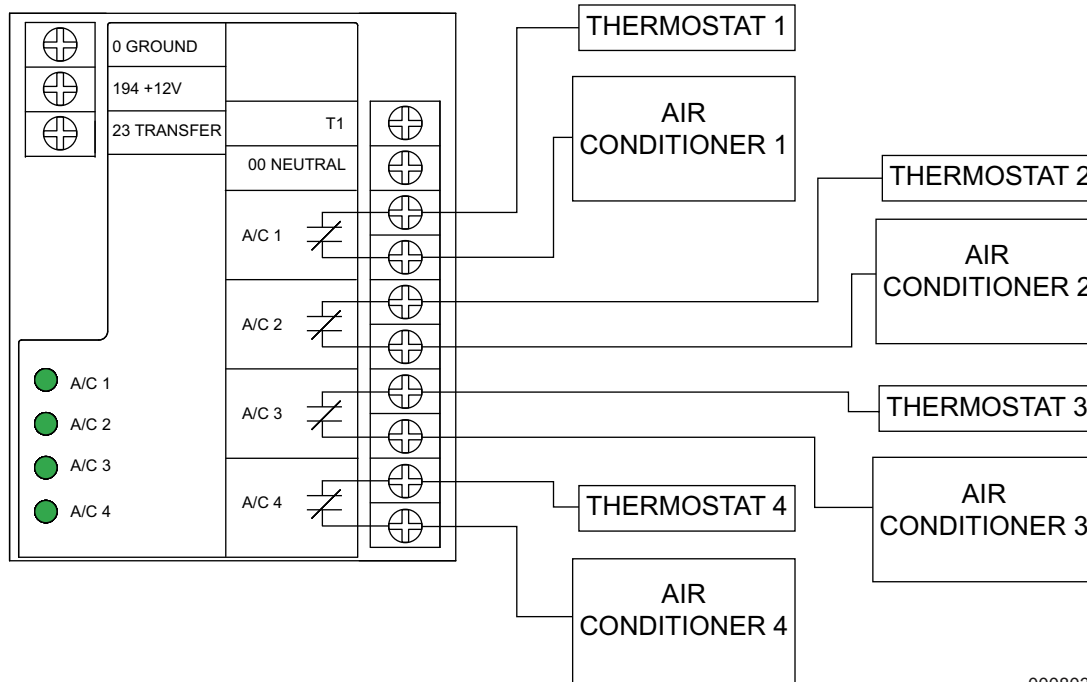

000803

Figure 3-1. Typical Smart A/C Connections

3.6 — Auxiliary Contacts

If desired, there are Auxiliary Contacts on the transfer switch to operate customer accessories, remote advisory lights, or remote annunciator devices. A suitable power source must be connected to the common terminal (D). See Figure 3-2.

Contact operation is shown in the following chart:

	Switch Position	
	Utility	Standby
Common to Normally Open	Open	Closed
Common to Normally Closed	Closed	Open

NOTE: Auxiliary Contacts are rated 10 amps at 125 or 250 volts AC.



Equipment damage. Exceeding rated voltage and current will result in damage to the auxiliary contacts.

(000134)

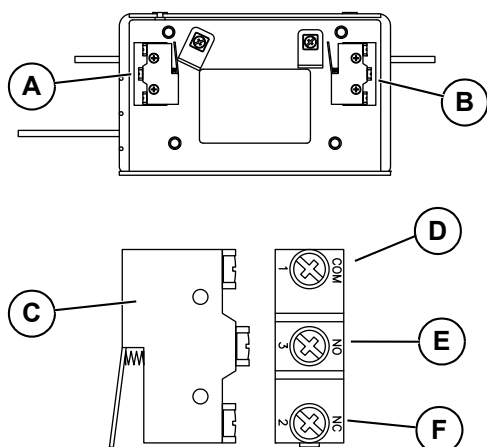

000140

Figure 3-2. Auxiliary Contacts

A	Auxiliary Contact (Actuated)
B	Auxiliary Contact (Non-Actuated)
C	Single Contact (Utility Position)
D	Common Terminal
E	Normally Open Terminal
F	Normally Closed Terminal

This page intentionally left blank.

Section 4 Operation

4.1 — Functional Tests and Adjustments

Following transfer switch installation and interconnection, inspect the entire installation carefully. A competent, qualified electrician should inspect it. The installation should comply strictly with all applicable codes, standards, and regulations. When absolutely certain the installation is proper and correct, complete a functional test of the system.

CAUTION

Equipment damage. Perform functional tests in the exact order they are presented in the manual. Failure to do so could result in equipment damage.

(000121)

IMPORTANT: Before proceeding with functional tests, read and make sure all instructions and information in this section is understood. Also read the information and instructions of labels and decals affixed to the switch. Note any options or accessories that might be installed and review their operation.

4.2 — Manual Operation



DANGER

Electrocution. Do not manually transfer under load. Disconnect transfer switch from all power sources prior to manual transfer. Failure to do so will result in death or serious injury, and equipment damage.

(000132)

A manual handle is shipped with the transfer switch. See 1 in Figure 4-1. Manual operation must be checked **BEFORE** the transfer switch is operated electrically. To check manual operation, proceed as follows:

1. Ensure the generator is in the OFF mode.
2. Turn OFF both UTILITY (service disconnect circuit breaker) and EMERGENCY (generator main line circuit breaker) power supplies to the transfer switch.
3. Note position of transfer mechanism main contacts by observing the movable contact carrier arm. This can be viewed through the long narrow slot in the inside cover of the ATS. The top of the movable contact carrier arm is yellow to be easily identified.
 - Manual operation handle in the UP position - LOAD terminals (T1, T2) are connected to UTILITY terminals (N1, N2).

- Manual operation handle in the DOWN position - LOAD terminals (T1, T2) are connected to EMERGENCY terminals (E1, E2).

CAUTION

Equipment damage. Do not use excessive force while manually operating the transfer switch. Doing so could result in equipment damage.

(000122)

4.2.1— Close to Utility Source Side

Before proceeding, verify the position of the switch by observing the position of manual operation handle in Figure 4-1. If the handle is UP, the contacts are closed in the NORMAL (UTILITY) position, no further action is required. If the handle is DOWN, proceed with Step 1.

1. With the handle inserted into the movable contact carrier arm (see A in Figure 4-1), move handle UP. Be sure to hold on to the handle as it will move quickly after the center of travel.
2. Remove manual operating handle from movable contact carrier arm. Return handle to storage bracket (see B in Figure 4-1).

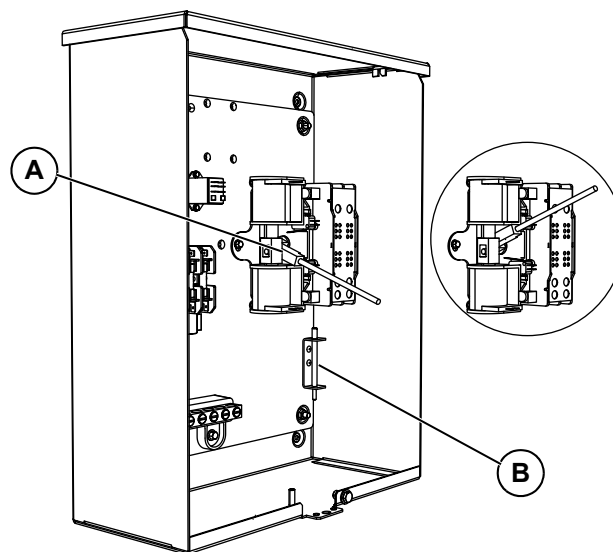

000228

Figure 4-1.

4.2.2— Close to Generator Source Side

Before proceeding, verify the position of the switch by observing the position of the manual operation handle in Figure 4-1. If the handle is DOWN, the

contacts are closed in the GENERATOR (STANDBY) position. No further action is required. If the handle is UP, proceed with Step 1.

1. With the handle inserted into the movable contact carrier arm, move the handle DOWN. Be sure to hold on to the handle as it will move quickly after the center of travel.
2. Remove manual operating handle from movable contact carrier arm. Return handle to storage bracket.

4.2.3— Return to Utility Source Side

1. Manually actuate switch to return manual operating handle to the UP position.
2. Remove manual operating handle from movable contact carrier arm. Return handle to storage bracket.

4.3 — Voltage Checks

4.3.1— Utility Voltage Checks

1. Turn ON the UTILITY power supply to the transfer switch using the utility service disconnect circuit breaker.



⚠ DANGER

Electrocution. High voltage is present at transfer switch and terminals. Contact with live terminals will result in death or serious injury.

(000129)

2. With an accurate AC voltmeter, check for correct voltage. Measure across ATS terminal lugs N1 and N2; N1 to NEUTRAL and N2 to NEUTRAL.



⚠ DANGER

Electrocution. Turn utility supply OFF before working on utility connections of the transfer switch. Failure to do so will result in death or serious injury.

(000123)

4.3.2— Generator Voltage Checks

1. On the generator panel, select the MANUAL mode of operation. The generator should crank and start.
2. Let the generator stabilize and warm up at no-load for at least five minutes.

3. Set the generator's main circuit breaker (CB1) to its ON or CLOSED position.



⚠ DANGER

Electrocution. High voltage is present at transfer switch and terminals. Contact with live terminals will result in death or serious injury.

(000129)

4. With an accurate AC voltmeter and frequency meter, check the no-load, voltage and frequency. Measure across ATS terminal lugs E1 to E2; E1 to NEUTRAL and E2 to NEUTRAL.

Frequency	60-62 Hz
Terminals E1 to E2	240-246 VAC
Terminals E1 to NEUTRAL	120-123 VAC
Terminals E2 to NEUTRAL	120-123 VAC

5. When certain that generator supply voltage is correct and compatible with transfer switch ratings, turn OFF the generator supply to the transfer switch.
6. Set the generator main circuit breaker (CB1) to OFF or OPEN.
7. On the generator panel, select the OFF mode to shut down the generator.

NOTE: Do NOT proceed until generator AC output voltage and frequency are correct and within stated limits. If the no-load voltage is correct but no-load frequency is incorrect, the engine governed speed may require adjustment. If no-load frequency is correct but voltage is not, the voltage regulator may require adjustment.

4.4 — Generator Tests Under Load

1. Set the generator main circuit breaker to OFF or OPEN.
2. Set the utility service disconnect circuit breaker to OFF or OPEN.
3. Manually actuate the transfer switch main contacts to the emergency (Standby) position. See “Manual Operation”.
4. To start the generator, select the MANUAL mode of operation. When engine starts, let it stabilize for a few minutes.
5. Set the generator main circuit breaker to ON or CLOSED. The generator now powers all LOAD circuits. Check generator operation under load as follows:
 - Turn on electrical loads to the full rated wattage/ amperage capacity of the generator. DO NOT OVERLOAD.

- With maximum rated load applied, check voltage and frequency across transfer switch terminals E1 and E2. Voltage should be greater than 230 VAC (240 VAC system); frequency should be greater than 59 Hz.
 - Verify that the gas pressure remains within acceptable parameters (see the generator Installation Guidelines manual).
 - Let the generator run under rated load for at least 30 minutes. With unit running, listen for unusual noises, vibration, overheating, etc., that might indicate a problem.
6. When checkout under load is complete, set main circuit breaker of the generator to the OFF or OPEN position.
 7. Let the generator run at no-load for several minutes. Then, shut down by selecting the OFF mode.
 8. Move the main switch contacts back to the utility position.

NOTE: See “Manual Operation”. Handle and operating lever of transfer switch should be in down position.

9. Turn on the utility power supply to transfer switch, using whatever means provided (such as a utility main line circuit breaker). The utility power source now powers the loads.
10. The system is now set for fully automatic operation.

4.5 — Checking Automatic Operation

To check the system for proper automatic operation, proceed as follows:

1. Verify generator is in OFF mode.
2. Verify switch is de-energized.
3. Install front cover of the transfer switch.
4. Turn the utility power supply to the transfer switch ON, using the utility main line circuit breaker.
5. Set the generator main circuit breaker to ON.
6. On the generator panel, select AUTO. The system is now ready for automatic operation.
7. Turn utility power supply to the transfer switch OFF.

With the generator ready for automatic operation, the engine should crank and start when the utility source power is turned OFF after a ten second delay (factory default setting). After starting, the transfer switch should connect load circuits to the standby side after a five (5) second delay. Let the system operate through its entire automatic sequence of operation.

With the generator running and loads powered by generator AC output, turn ON the utility power supply to the transfer switch. The following should occur:

- After approximately 15 seconds, the switch should transfer loads back to the utility power source.
- Approximately one minute after re-transfer, the engine should shut down.

With the generator in the AUTOMATIC mode, the system is now set for fully automatic operation.

4.6 — Installation Summary

1. Verify the installation has been properly performed as outlined by the manufacturer and that it meets all applicable laws and codes.
2. Verify proper operation of the system as outlined in the appropriate installation and owner’s manuals.
3. Educate the end-user on the proper operation, maintenance and service call procedures.

4.7 — Shutting Generator Down While Under Load

Important! To turn the generator off during utility outages to perform maintenance, or conserve fuel, follow these steps:

To turn the generator OFF (while running in AUTO and online):

1. Turn the main utility disconnect OFF.
2. Turn the main line circuit breaker (MLCB) on the generator to OFF (OPEN).
3. Turn the generator OFF.

To turn the generator back ON:

1. Put the generator back into AUTO and allow to start and warm-up for a few minutes.
2. Set the MLCB on the generator to ON.

The system will now be operating in automatic mode. The main utility disconnect can be turned ON (CLOSED).

If Utility returns, the transfer switch will return to utility mode and the generator will cycle off after it times out.

4.8 — Testing The Smart A/C Module

A Test pushbutton is provided on the bottom of the Smart A/C Module to test the operation of the load shed functions. The Test button will work when the ATS is in the Utility or the Generator position.

1. Turn on the Utility supply to the ATS.
2. Verify managed loads are powered and all LEDs illuminate on Smart A/C Module.
3. Press the TEST button on the Smart A/C Module.
4. Verify that all of the connected loads to be “shed” become disabled.

5. After five (5) minutes verify A/C 1 is energized and Status LED A/C 1 is ON.
6. After another 15 seconds, verify A/C 2 is energized and Status LED A/C 2 is ON.
7. After another 15 seconds, verify Load A/C 3 is energized and Status LED Load A/C 3 is ON.
8. After another 15 seconds, verify A/C 4 is energized and Status LED A/C 4 is ON.

4.9 — Testing The Smart Management Module

Refer to the SMM Owner's/Installation Manual for testing that product.

Section 5 Drawings and Diagrams

5.1 — Installation Drawing

5.1.1— No. 0G6832-A 100A SE & non-SE/150-200A non-SE

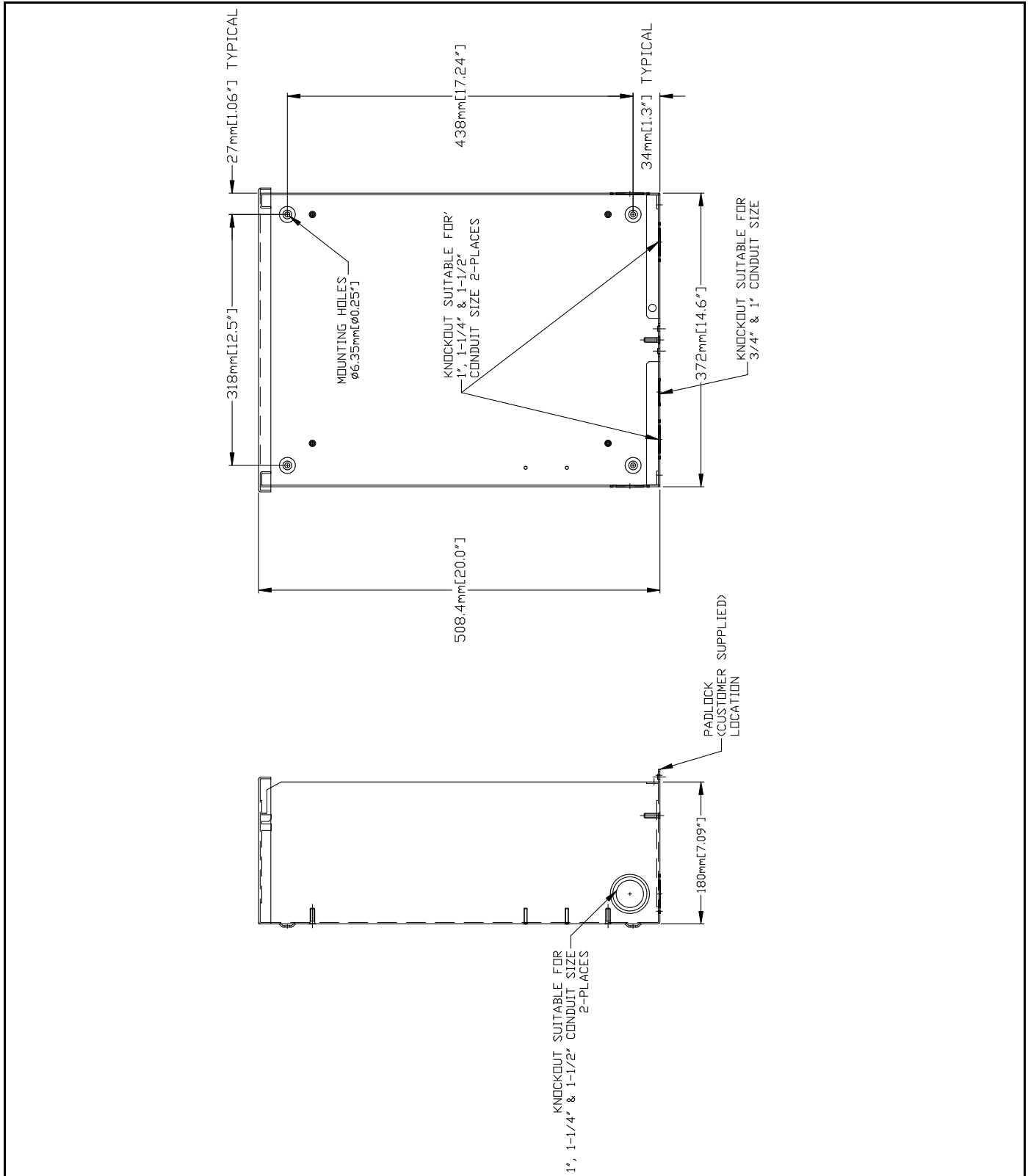

5.1.2— No. 0K2422-A 150/200A SE

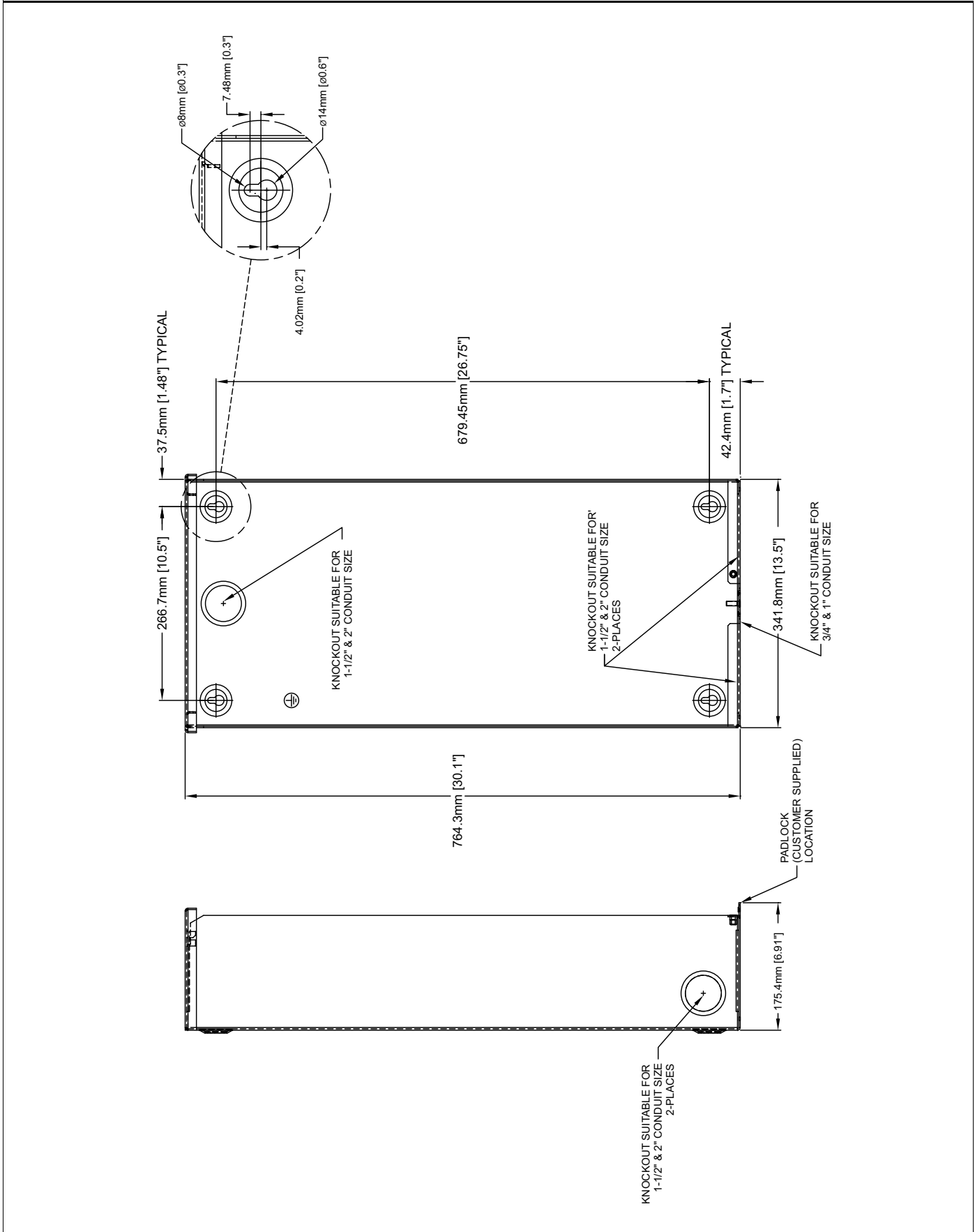

This page intentionally left blank.

5.2 — Interconnection Drawing

5.2.1— No. 0L3240-A (Part 1 of 4) Liquid-cooled Generator

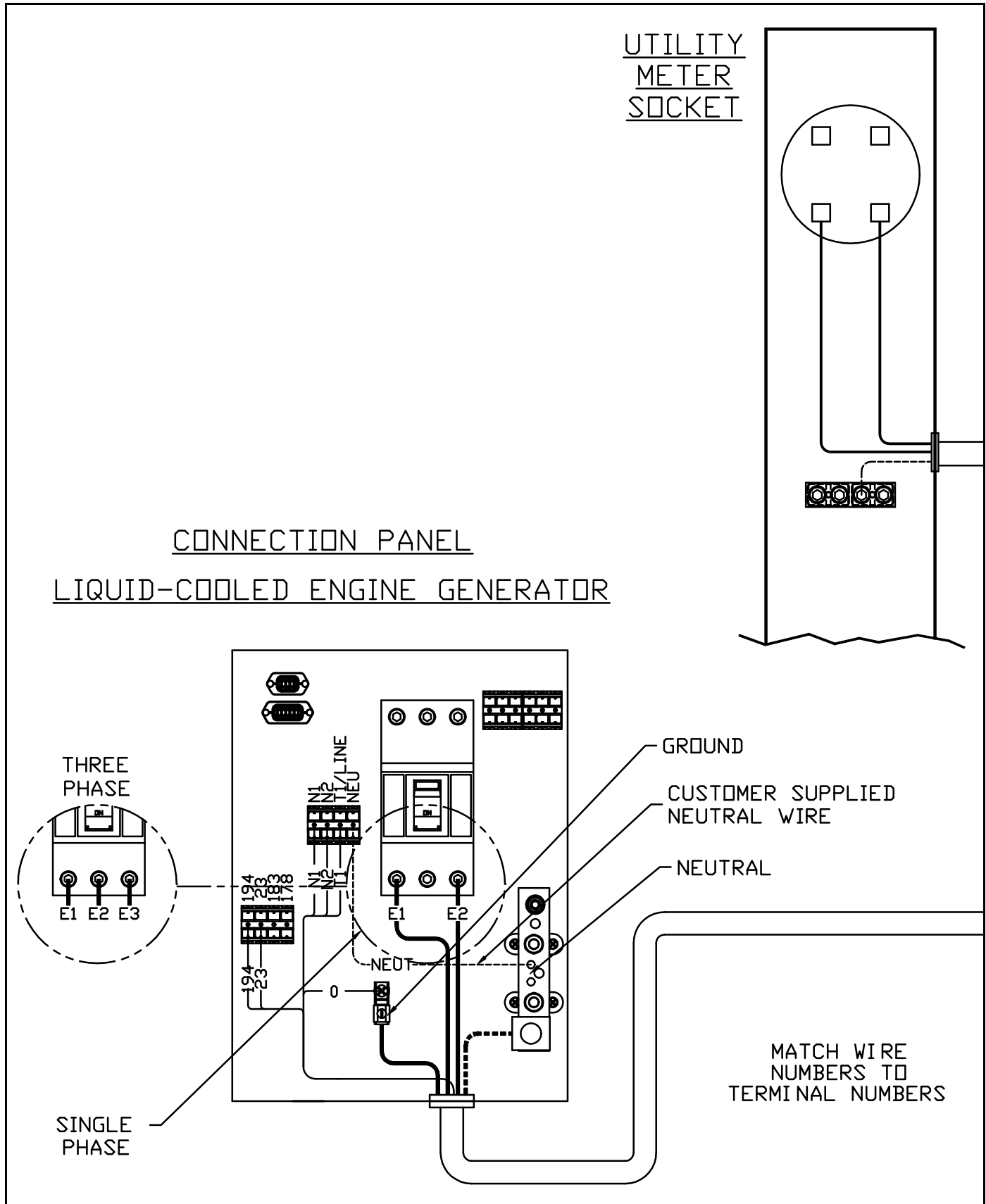

5.2.2— No. 0L3240-A (Part 2 of 4) Liquid-cooled Generator

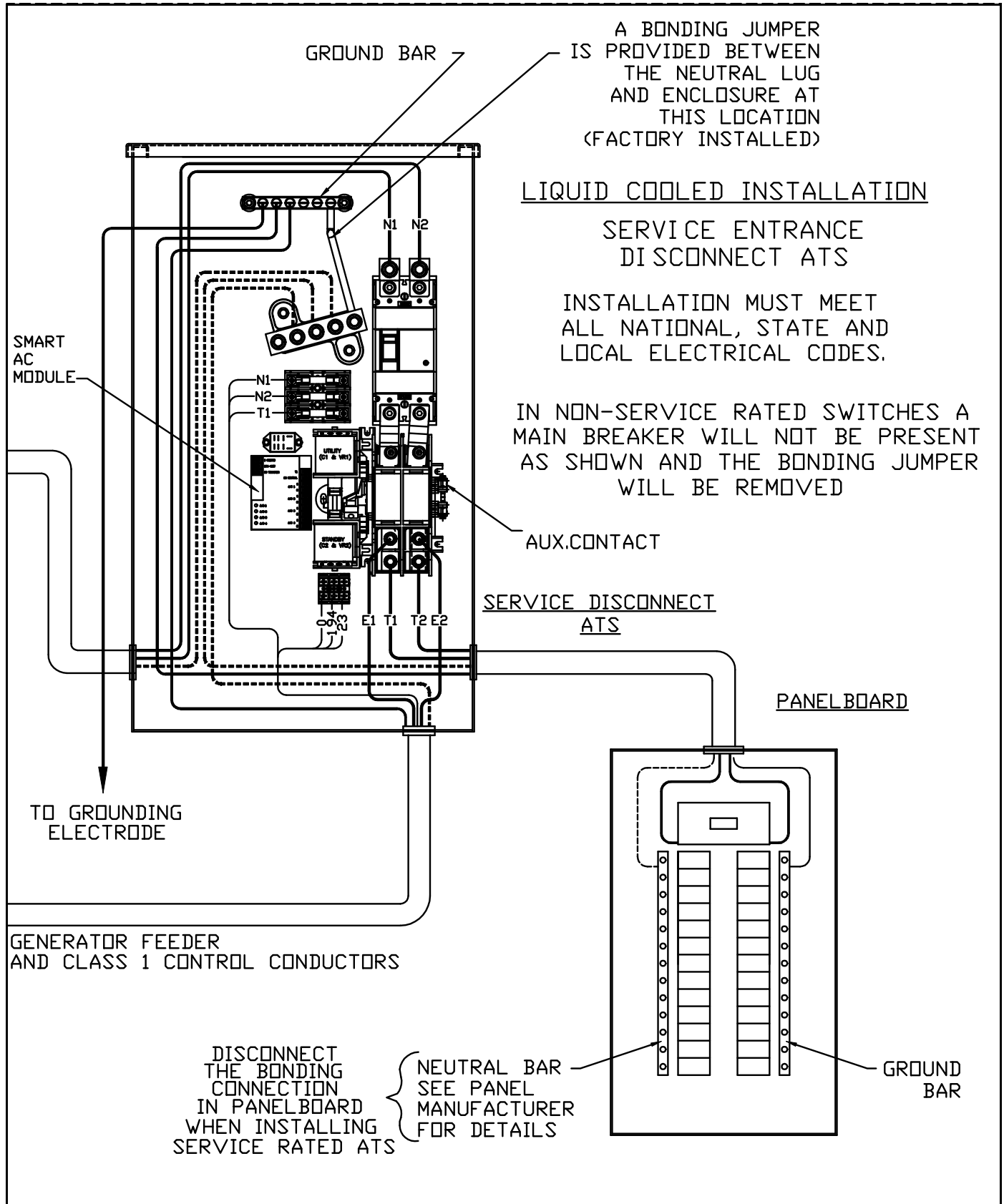

5.2.3— No. 0L3240-A (Part 3 of 4) Air-cooled Generator

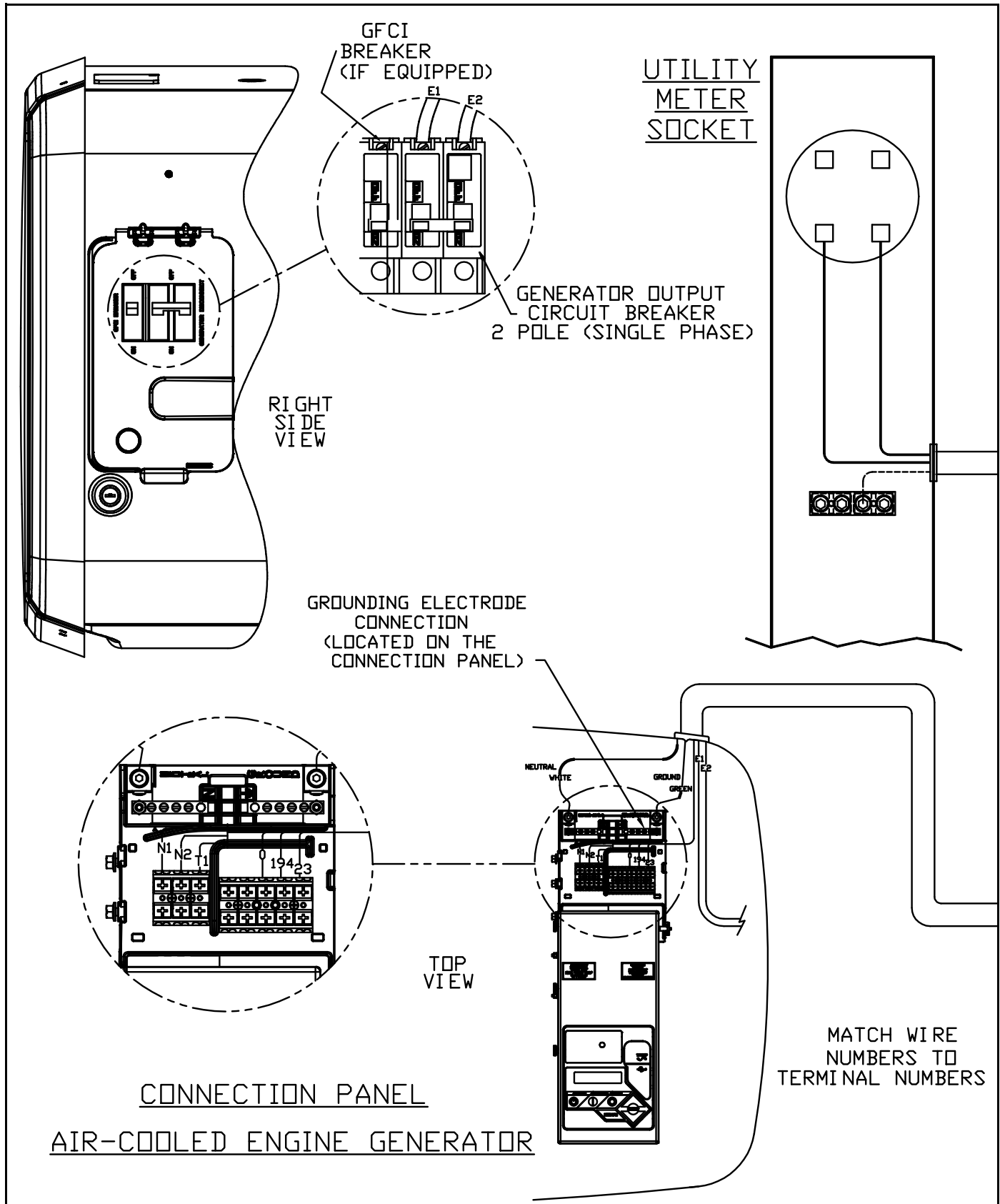

5.2.4— No. 0L3240-A (Part 4 of 4) Air-cooled Generator

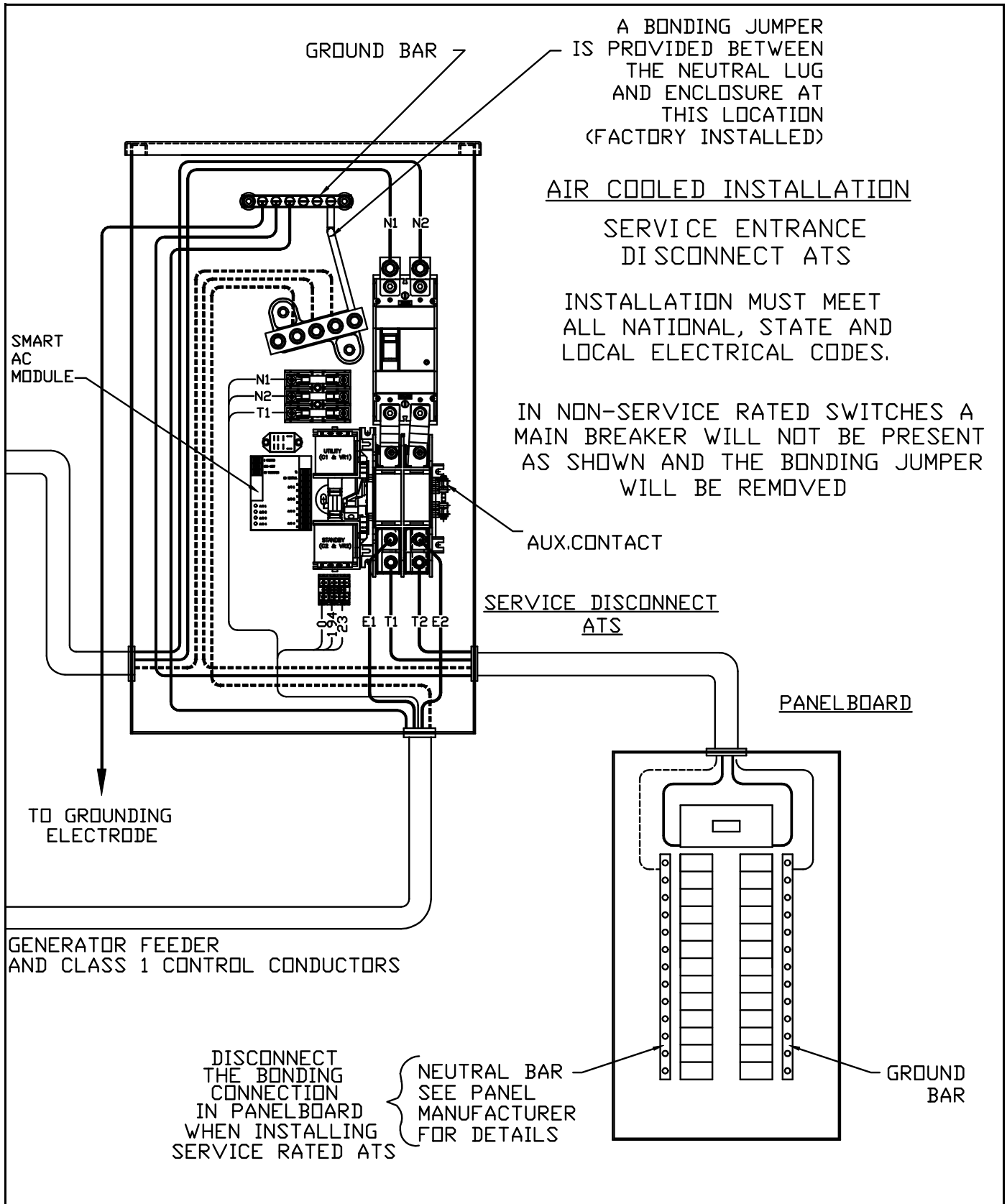

This page intentionally left blank.

Part No. 0L3202 Rev. A 05/15/15 Printed in USA
©2015 Generac Power Systems, Inc. All rights reserved
Specifications are subject to change without notice.
No reproduction allowed in any form without prior written
consent from Generac Power Systems, Inc.

GENERAC[®]



Generac Power Systems, Inc.
S45 W29290 Hwy. 59
Waukesha, WI 53189
1-888-GENERAC (1-888-436-3722)
generac.com

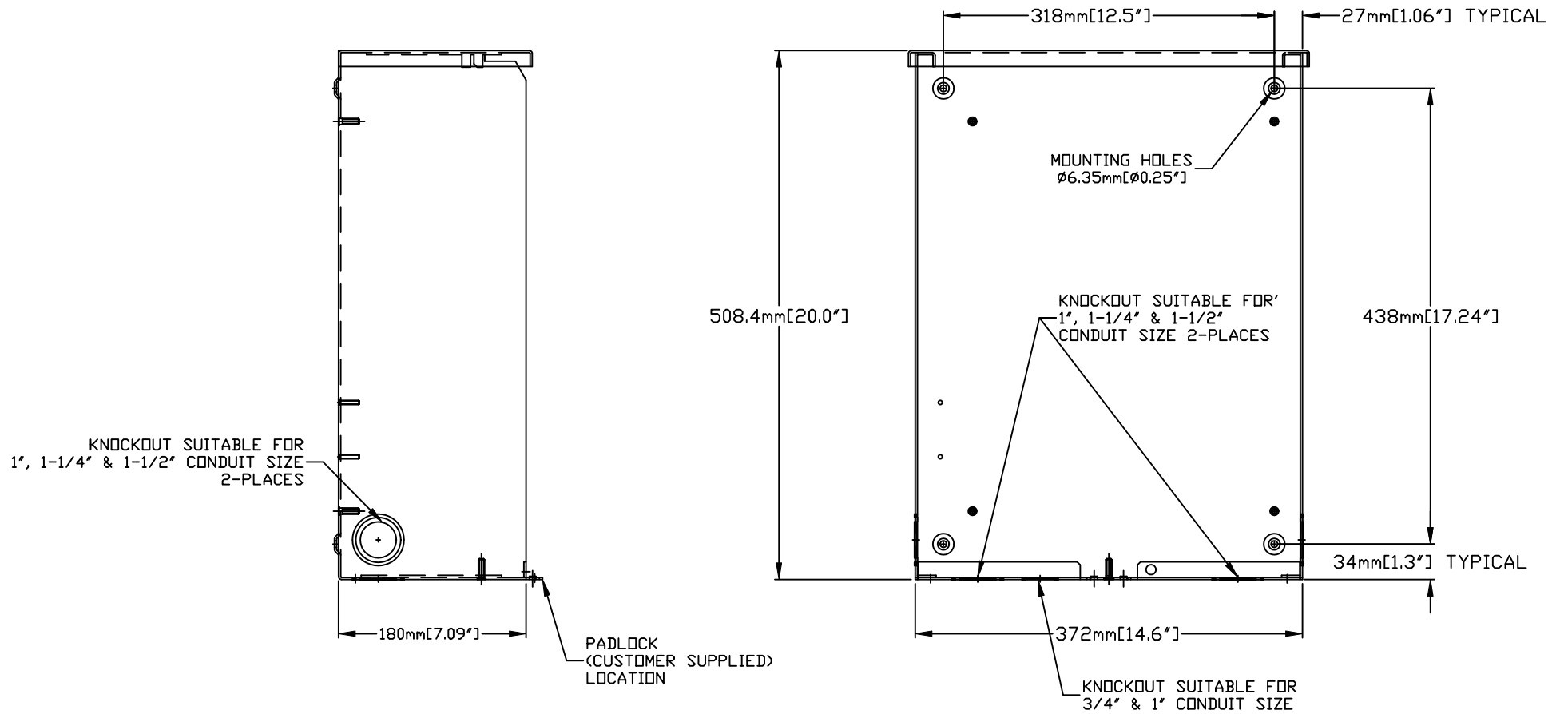

GROUP G

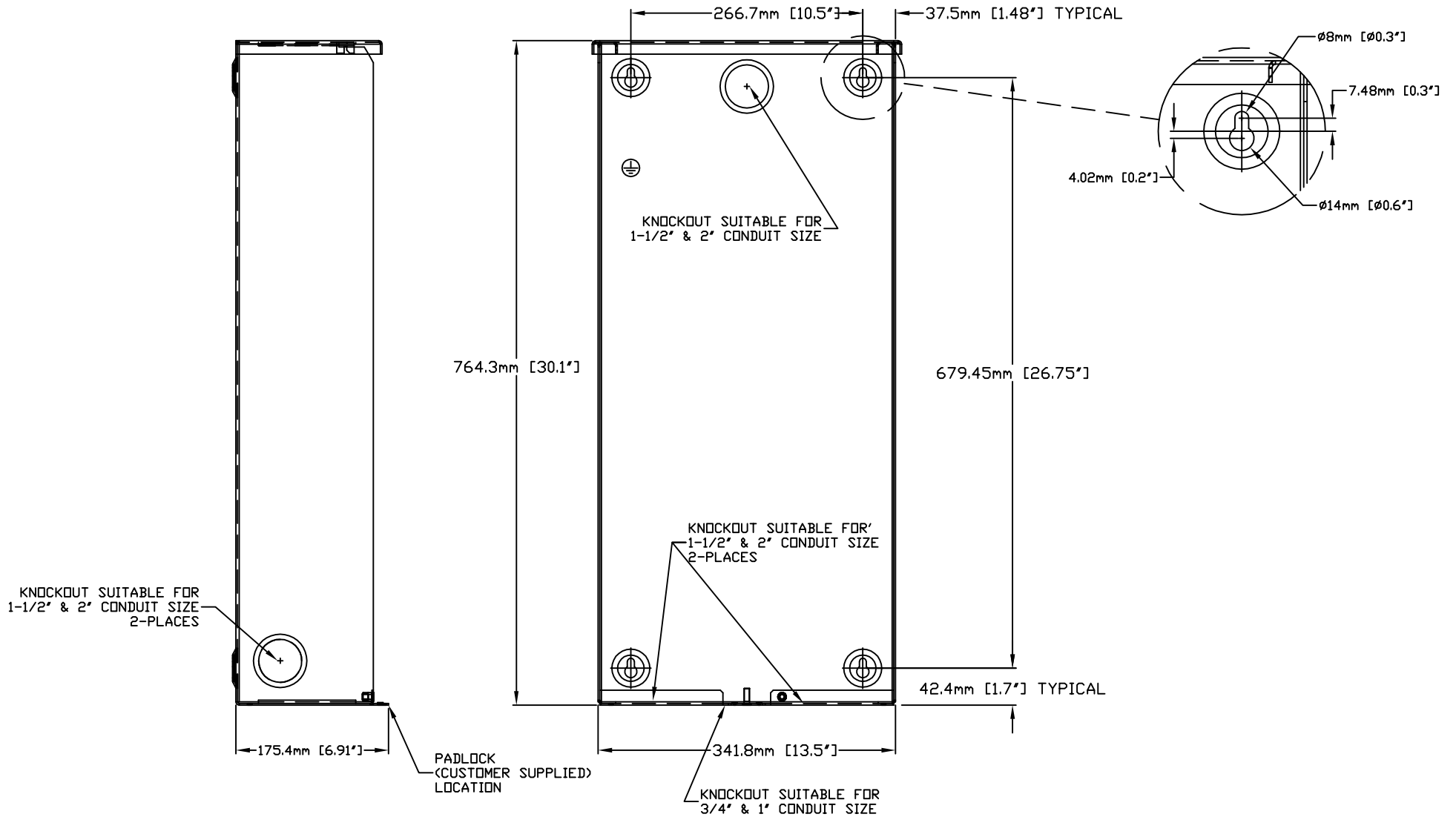

THIS PAGE IS LEFT INTENTIONALLY BLANK