

Owner's/Installation Manual 50A Generac Load Manager (LM)

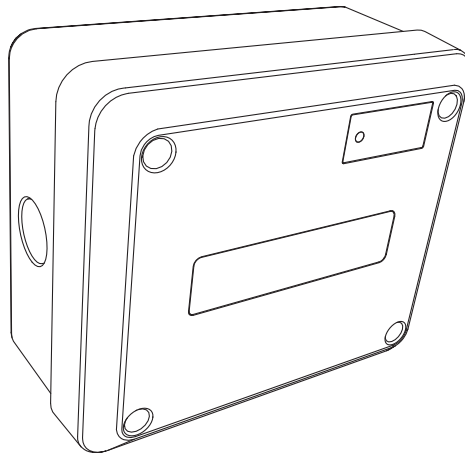

MODEL: G0070001

DATE PURCHASED: _____



WARNING

Loss of life. This product is not intended to be used in a critical life support application. Failure to adhere to this warning could result in death or serious injury. (000209b)

WWW.GENERAC.COM
1-888-GENERAC
(1-888-436-3722)

Para español , visita: <http://www.generac.com/service-support/product-support-lookup>

Pour le français, visiter : <http://www.generac.com/service-support/product-support-lookup>



SAVE THIS MANUAL FOR FUTURE REFERENCE

 **WARNING**

CANCER AND REPRODUCTIVE HARM

www.P65Warnings.ca.gov

(000393a)

Table of Contents

Section 1: Introduction and Safety

Introduction	1
Read This Manual Thoroughly	1
Safety Rules	1
General Hazards	1

Section 2: General Information and Setup

Load Management Options	3
Application Considerations	3
Generac Load Manager (LM)	3
LM and Carton Contents	4
Setting Lockout	5
Adjusting Frequency and Frequency Sensitivity	5

Section 3: Installation, Tests, & Troubleshooting

Electrical Specifications	9
Enclosure Specifications	9
Remove Contents from Carton	9
Tools Needed For Installation	9
Mounting Instructions	9
Connections	10
Setting Priorities	11
Tests	11
Utility Test	11
Installation Summary	11
Troubleshooting	12

This page intentionally left blank.

Section 1: Introduction and Safety

Introduction

Thank you for purchasing a Generac Load Manager (LM). LMs are designed to work together to prevent the home standby generator from being overloaded by large appliance loads. The LMs require no control wires, and provide a cost effective, quick installation. Use of up to eight modules is available, allowing protection of your home and necessary appliances.

The information in this manual is accurate based on products produced at the time of publication. The manufacturer reserves the right to make technical updates, corrections, and product revisions at any time without notice.

Read This Manual Thoroughly



Consult Manual. Read and understand manual completely before using product. Failure to completely understand manual and product could result in death or serious injury. (000100a)

If any section of this manual is not understood, contact the nearest Independent Authorized Service Dealer (IASD) or Generac Customer Service at 1-888-436-3722 (1-888-GENERAC), or visit www.generac.com for starting, operating, and servicing procedures. The owner is responsible for correct maintenance and safe use of the unit.

This manual must be used in conjunction with all other supporting product documentation supplied with the product.

SAVE THESE INSTRUCTIONS for future reference. This manual contains important instructions that must be followed during placement, operation, and maintenance of the unit and its components. Always supply this manual to any individual that will use this unit, and instruct them on how to correctly start, operate, and stop the unit in case of emergency.

Safety Rules

The manufacturer cannot anticipate every possible circumstance that might involve a hazard. The alerts in this manual, and on tags and decals affixed to the unit, are not all inclusive. If using a procedure, work method, or operating technique that the manufacturer does not specifically recommend, verify that it is safe for others and does not render the equipment unsafe.

Throughout this publication, and on tags and decals affixed to the unit, DANGER, WARNING, CAUTION, and NOTE blocks are used to alert personnel to special

instructions about a particular operation that may be hazardous if performed incorrectly or carelessly. Observe them carefully. Alert definitions are as follows:



Indicates a hazardous situation which, if not avoided, will result in death or serious injury.

(000001)



Indicates a hazardous situation which, if not avoided, could result in death or serious injury.

(000002)



Indicates a hazardous situation which, if not avoided, could result in minor or moderate injury.

(000003)

NOTE: Notes contain additional information important to a procedure and will be found within the regular text of this manual.

These safety alerts cannot eliminate the hazards that they indicate. Common sense and strict compliance with the special instructions while performing the action or service are essential to preventing accidents.

General Hazards



Electrocution. Turn utility and emergency power supplies to OFF before connecting power source and load lines. Failure to do so will result in death or serious injury. (000116)

This page intentionally left blank.

Section 2: General Information and Setup

Load Management Options

Load management systems are designed to work together to prevent a generator from being overloaded by large appliance loads. Options include:

- Generac Load Managers (LMs)
- Smart A/C Module (SACM)—standard in single-phase 100-800 Amp RTS or RXS transfer switches.

These options can be used in conjunction or separately.

Application Considerations

Generator overload condition is determined by generator frequency. Loads are shed when frequency drops below a preset value for a predetermined time.

A LM can be used individually or in conjunction with a SACM to manage a combined total of eight loads. LMs operate independently when used in conjunction with the SACM.

- Use Priorities A/C 1–4 on the SACM as the top priorities, then up to four LMs as Priorities 5–8.
- Use only select A/C priorities on the SACM as the top priorities, then use additional LMs as the remaining priorities.
- To reduce the loads returned to the generator all at once, it is best to set the LMs priorities to follow after the last HVAC load has returned. This allows the generator to accept loads gradually, reducing the potential for additional nuisance load shed events.

In any combination of modules, the recovery times after a loss of utility power or shutdown due to overload are shown in [Table 2-1](#).

NOTE: For digital thermostats where a 24 VAC thermostat wire is not available, a LM must be used to break the power at the HVAC load itself.

Generac Load Manager (LM)

Any 240V loads, including central air conditioners, can be managed using a LM. The system can accommodate up to eight individual LMs.

NOTE: LMs are self-contained and have individual built-in controllers.

Table 2-1. Priority Settings

Priority	Recovery Time	SACM	LM
1	5 minutes	Yes	Yes
2	5 minutes 15 seconds	Yes	Yes
3	5 minutes 30 seconds	Yes	Yes
4	5 minutes 45 seconds	Yes	Yes
5	6 minutes	NA	Yes
6	6 minutes 15 seconds	NA	Yes
7	6 minutes 30 seconds	NA	Yes
8	6 minutes 45 seconds	NA	Yes

LM and Carton Contents

Priority Dial (A) – Sets LM priority.

NOTE: PRIORITY MUST BE DIFFERENT for each LM in an installation. Priority sets the order in which loads recover from a load shed event. Recovery time from a load shed event is five minutes for Priority 1. Each priority after Priority 1 waits an additional 15 seconds after the initial recovery time. See [Table 2-1](#).

Lockout Switch (B) – Enables or disables lockout function. Switch positions are LOCKOUT LOAD ON GENERATOR (enabled) and LOCKOUT DISABLED. See [Table 2-2](#).

NOTE: Recovery time is based on priority dial settings. See [Table 2-1](#).

Test Button (C) – Disables contactor output for a specified time.

LED (D) – Provides LM status. See [Table 2-3](#).

Contactor (E) – Normally CLOSED. If the generator begins to overload, the contactor opens to take the load off generator power. The contactor also opens to take the load off generator power. See [Connections](#).

Mounting Holes (F) – Internal enclosure mounting holes provide clean and sturdy mounting.

Priority Decal (G) – Provided for recording priority of each LM in installation. Install on electrical panel.

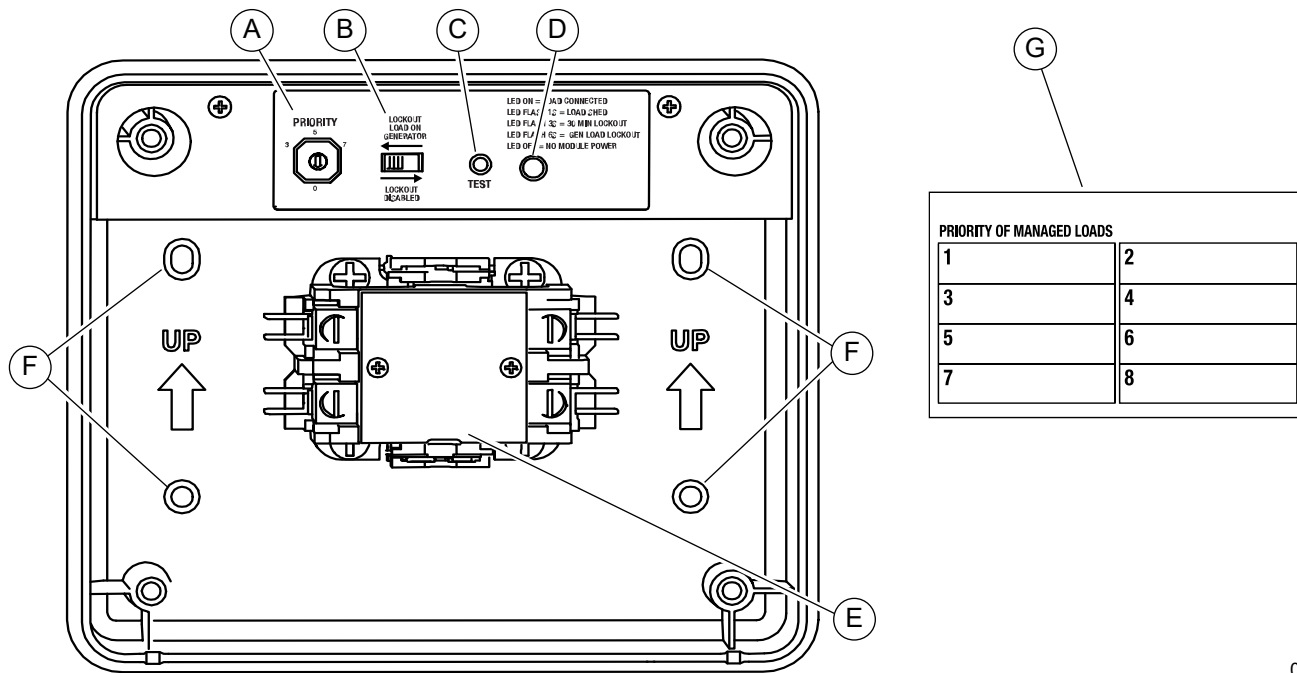

Figure 2-1. LM Features and Controls

000106

Setting Lockout

LMs are equipped with a lockout provision. The LM can be set to enable LOCKOUT mode if load is identified as non-essential and does NOT need to operate on backup power during generator overload. Load can be a single electrical load or an entire subpanel of multiple branch circuits.

NOTE: LOCKOUT mode works in an overload condition, which is determined by generator frequency. If generator has sufficient capacity, the load will be allowed to turn on even if control is set to LOCKOUT mode.

See [Figure 2-2](#). Slide lockout switch (1) to LOCKOUT LOAD ON GENERATOR to set LM to enable lockout function while using generator power. Slide lockout switch (1) to LOCKOUT DISABLED to disable lockout function while using generator power.

Adjusting Frequency and Frequency Sensitivity

See [Figure 2-2](#). The LM control board is equipped with two movable jumpers (2). Jumper locations are indicated on the diagram:

- (3) Frequency Jumper - default for 60 Hz
- (4) Frequency Sensitivity - Default (A) for 59.8–60.2 Hz

NOTE: Change in jumper (4) may be leveraged for applications where the utility power experiences variable frequency and load shed false triggers may occur. If frequency instability is commonly experienced on utility, jumper (4) may be set to B position to increase load shed activation window by 2Hz from 59.8–60.2 Hz to 58–62 Hz. This makes the LM less susceptible to frequency variability.

IMPORTANT NOTE: Jumper (3) should remain in place unless in an area with 50 Hz power.

Proceed as follows to move a jumper:

1. Remove power.
2. Grasp jumper and pull straight up until it clears the pins.
3. Move jumper to new location and press it gently onto the pins until seated.

NOTE: To avoid bending or breaking pins, do not rock jumper, use excessive force, or pull sideways to remove it from the LM control board.

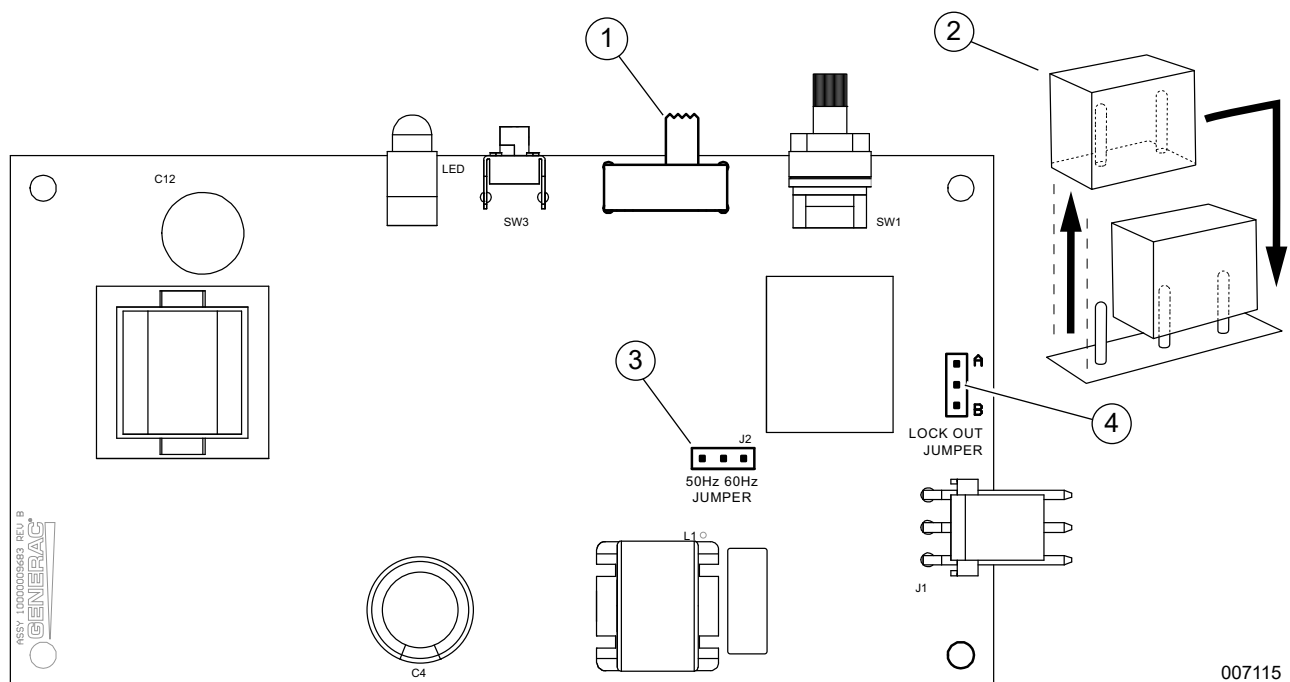

Figure 2-2. Jumper Locations

007115

Table 2-2. Lockout Switch Settings

Lockout Switch Setting	Mode Selector Jumper Position	Mode	Function
LOCKOUT LOAD ON GENERATOR	A	Generator	LM sheds load and does not reconnect until utility returns or overload goes away. See Setting Lockout . This setting is considered standard for most installations.
LOCKOUT LOAD ON GENERATOR	B	Generator	LM sheds load and does not reconnect until utility returns or overload goes away. This setting is recommended for installations in areas with unstable frequency power as described in Setting Lockout .
LOCKOUT LOAD ON GENERATOR	A or B	Utility	Power is available on LM output.
LOCKOUT DISABLED	A or B	Generator	LM operates with standard load shed logic. See Table 2-1 for more information.
LOCKOUT DISABLED	A or B	Utility	Power is available on LM output.

NOTE: Duration of Return to Utility timer is longer in Mode B.

Table 2-3. LED States

State	LED State	Mode	Note
Shed	1 second flash (1 On – 1 Off)	Generator	LM detected an overload and shed its load. This state only occurs in generator mode, or during a first time utility power-up for five minutes of initial operation.
Lockout (30 minutes)	3 second flash (3 On – 3 Off)	Generator	LM detected an overload while trying to recover from a shed situation. Operation is disabled for 30 minutes. This state only occurs in generator mode.
Lockout Switch Active	6 second flash (6 On – 6 Off)	Generator	LM output is disabled and there is no power to the appliance while in generator mode and generator is overloaded. Lockout switch must be ON. See Table 2-2 .
Lockout Switch Active	ON	Utility	Lockout switch operates in generator mode only. It has no function in utility mode. LED is solid, indicating the load is connected. Lockout switch must be ON. See Table 2-2 .
Normal	ON	Generator or Utility	Indicates the appliance has power. This is the default in utility mode. It is the normal operating state in generator mode when an overload is not detected.
Test	1 second flash	Generator or Utility	Test button triggers a typical shed condition and overrides all other states except generator lockout switch ACTIVE state. NOTE: Actual test time varies depending on LM priority setting. Use the following formula to calculate test time: Time = (P-1) x 15 seconds, where P represents priority setting. Example: LM Priority 6 test time = (6-1) x 15 seconds, or 75 seconds.

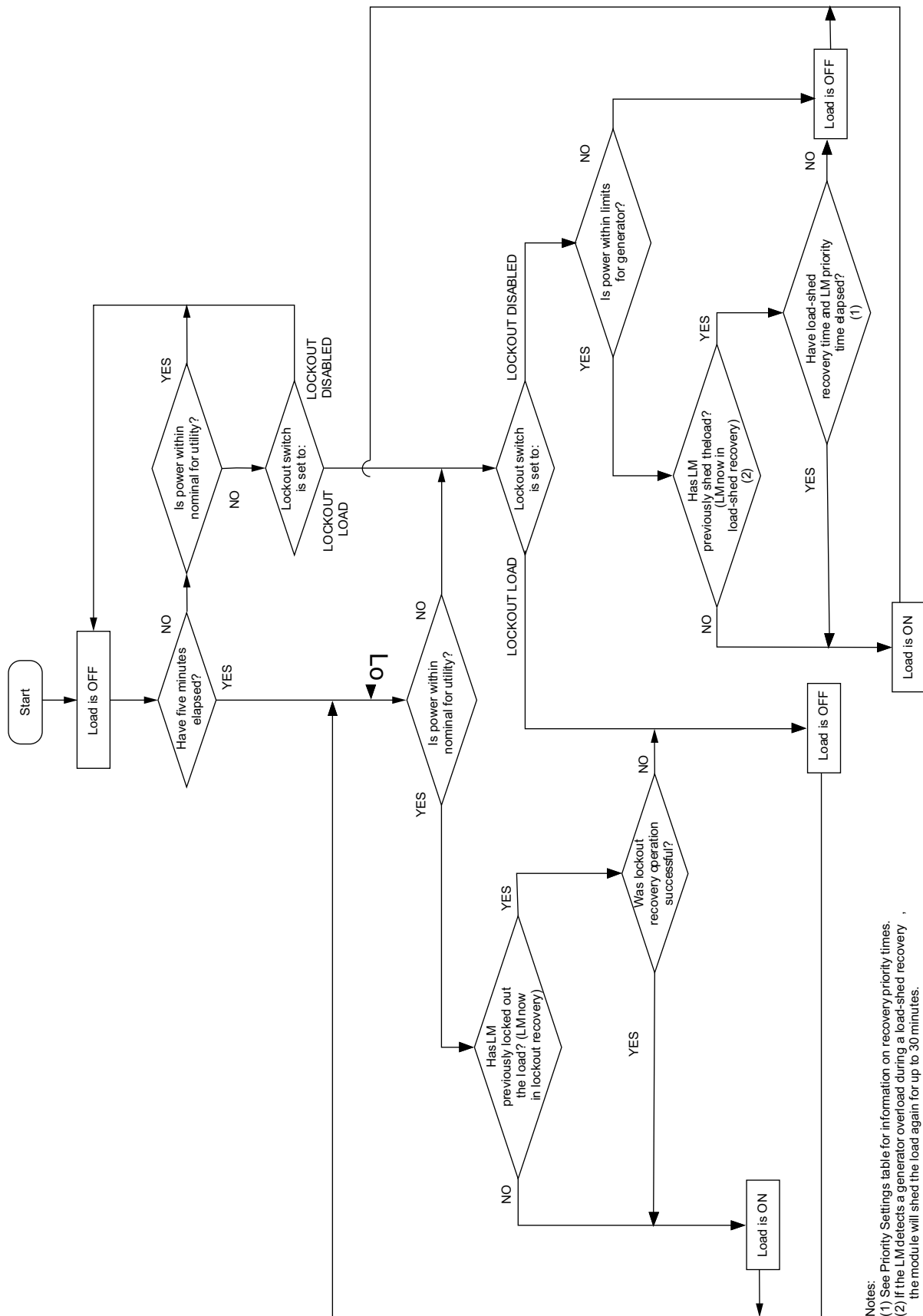

Notes:
 (1) See Priority Settings table for information on recovery priority times.
 (2) If the LM detects a generator overload during a load-shed recovery, the module will shed the load again for up to 30 minutes.

007111

Figure 2-3. LM Sequence of Operations

This page intentionally left blank.

Section 3: Installation, Tests, & Troubleshooting

Electrical Specifications

Input voltage	240 VAC
Current rating	50A resistive, 40A inductive
Locked rotor amp rating	180A
Motor rating	3 HP
Contactors coil voltage	240 VAC

Enclosure Specifications

Enclosure	Type 3R
Temperature	-22 to 122 °F (-30 to 50 °C)

Remove Contents from Carton

1. Open carton.
2. Remove and verify carton contents:
 - LM
 - Priority decal
 - Owner/installation manual
3. Retain carton for mounting template.
4. Contact place of purchase with unit model number to report any missing carton contents.
5. Record date of purchase on front cover of this manual.

Tools Needed For Installation

- Power drill and suitable drill bit
- Phillips and flat head screwdrivers
- Mounting screws or wall anchors
- Electrical materials
- Voltmeter to indicate voltage presence

NOTE: Use the Digital Multimeter (DMM) LowZ low input impedance setting to collect accurate voltage measurements. LowZ eliminates the possibility of inaccurate ghost voltage readings, also known as phantom voltage or stray voltage readings. See DMM manufacturer's literature for additional information.

Mounting Instructions



⚠ DANGER

Electrocution. Turn utility and emergency power supplies to OFF before connecting power source and load lines. Failure to do so will result in death or serious injury. (000116)

Recommended installation is near the electrical panel or appliance/load. The enclosure has a NEMA 3R rating and can be mounted indoors or outdoors. It provides a degree of protection against rain and sleet and is undamaged by the formation of ice on the enclosure.

1. Turn OFF both UTILITY (NORMAL) and EMERGENCY (STANDBY) power supplies.
2. Choose mounting location (near electrical panel, appliance or load to be managed).
3. See [Figure 3-1](#). Use a flat head screwdriver to remove appropriate knockouts (A) from LM enclosure for wiring.

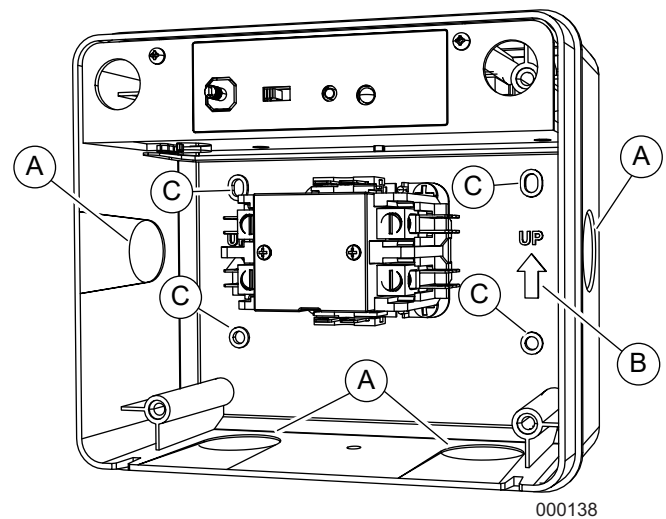
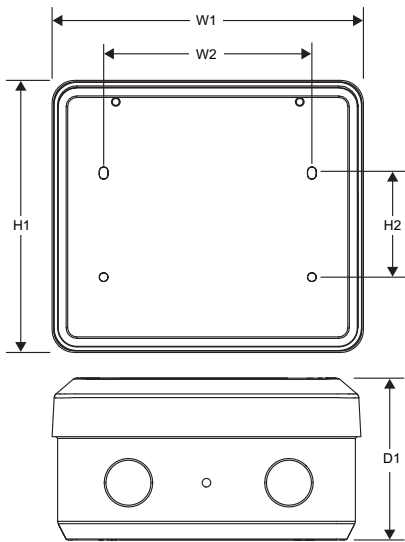

Figure 3-1. Knockouts and UP Arrows

NOTE: If outdoor installation is chosen, bottom knockouts must be used to meet NEMA 3R rating and protect against water ingress.

4. Hold LM enclosure against mounting surface with arrows (B) pointing up, and mark or drill four mounting holes (C).

NOTE: See *Figure 3-2* for mounting dimensions if needed.



000107

Figure 3-2. Mounting Dimensions

Height (in/mm)	H1	6.17 / 156.8
	H2	2.36 / 60
Width (in/mm)	W1	7.06 / 179.4
	W2	4.72 / 120
Depth (in/mm)	D1	3.7 / 94

5. Install LM enclosure to mounting surface using appropriate mounting screws or wall anchors.

Connections



⚠ DANGER

Electrocution. Turn utility and emergency power supplies to OFF before connecting power source and load lines. Failure to do so will result in death or serious injury. (000116)

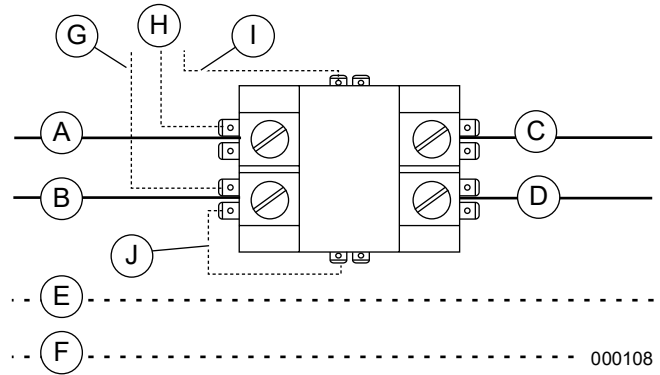

000108

Figure 3-3. Wiring Diagram

Legend	
A	Red (240 VAC - Line)
B	Black (240 VAC - Line)
C	Red (240 VAC - Load)
D	Black (240 VAC - Load)
E	White - Neutral (as required)
F	Green - Ground (as required)
G	Black - Factory (PCB)
H	Red - Factory (PCB)
I	Blue - Factory (PCB)
J	Blue - Factory (Jumper)

1. Turn off both UTILITY (NORMAL) and EMERGENCY (STANDBY) power supplies before connecting power source and load lines to transfer switch and LM.

NOTE: Suitable conduit fittings must be installed in knockout openings when running supply and load wires.

NOTE: Use at least 167 °F (75 °C) rated wire and gauge per installation instructions. See [Table 3-1](#) for recommended wire size based on load current.

Table 3-1. Recommended Wire Sizes

Temperature rating of conductor: 167 °F (75 °C)	
Conductor types (must be copper): RHW, THHW, THW, THWN, XHHW, USE, ZW	
Size AWG	Maximum Current Rating
14	15A
12	20A
10	30A
8	50A*
* 40A for Type NM cable	

2. Run line supply wires per applicable NEC code articles for wiring method selected.
3. Run load wires per applicable NEC code articles for wiring method selected.
4. See [Figure 3-3](#). Connect line supply wiring (A, B) to line side of LM contactor field terminals. Tighten field terminals to 25 **in-lb** (2.8 Nm).
5. Connect load supply wiring (C, D) to load side of LM contactor field terminals.

NOTE: If neutral (E) and ground (F) wires are included, connect inside LM using a listed termination device.

The unit is now ready to configure, apply power, and perform testing.

Setting Priorities

High priority 240 VAC loads should be set to the highest priorities so those loads recover first in the event of generator overload.

NOTE: Priority 1 is the highest priority and first load to activate. Priority 8 is the last load to activate.

Setting priority determines timing for three scenarios:

- Order in which loads recover
- Delay time until power returns during an outage
- Delay time for post load shed recovery

An example configuration is shown below. Configurations will vary depending on customer prioritization of loads:

Priority 1 - Baseboard heat	Priority 5 - Non-essential circuits
Priority 2 - Air conditioner	Priority 6 - Pool pump or hot tub
Priority 3 - Range	Priority 7 - Other circuits
Priority 4 - Clothes Dryer	Priority 8 - Other circuits

1. Set the priority of each LM as desired (using the example configuration for reference).
2. Apply priority decal in a suitable location on electrical panel to record chosen priority designations.
3. Record priorities on decal.

Tests

Utility Test

1. Turn utility power ON and enable all LM feeding circuits.
2. Verify LED begins to flash at one second intervals.
3. All contactors will close after five minutes. LED will illuminate and remain ON.

NOTE: The five minute delay allows magnetism to dissipate from the air conditioner compressor. This allows easier starting and eliminates potential for reverse compressor operation.

Installation Summary

- Install cover on electrical panel.
- Install covers on LMs.

Troubleshooting

See [Table 3-2](#) for troubleshooting problems, causes, and corrections.

Table 3-2. Troubleshooting

Problem	Cause	Correction
Load not powered; LED is OFF	Circuit breaker disabled.	Enable circuit breaker.
Load not powered; LED is OFF	Utility main line circuit breaker (MLCB) disabled and generator OFF.	Enable utility MLCB if utility is present or verify generator operation if outage.
Load not powered; LED flashing 1 second interval	Generator power just applied to unit. Utility power just applied to unit. Generator was overloaded and shed occurred.	Wait five minutes plus the priority time delay (see Table 2-1) for unit to enable output.
Load not powered; LED flashing 3 second interval	This load overloaded the generator while attempting recovery from a shed. It is in a 30 minute lockout wait period.	Wait 30 minutes from lockout for unit to attempt to re-apply load. Review all loads enabled in household. Generator may end up in another overload condition when this load is enabled. Disable some loads to prevent generator overload from recurring.
Load not powered; LED flashing 6 second interval	The lockout switch is enabled and the unit is on generator power.	During installation, it was determined that this load will be disabled during generator operation to prevent generator overload. Contact IASD for details.
Load not powered while on utility	Wiring or unstable frequency.	Inspect wiring. See Setting Lockout for information on unstable frequency.

This page intentionally left blank.

This page intentionally left blank.

Part No. 1000030493 Rev. F 08/13/2024
©2024 Generac Power Systems, Inc.
All rights reserved.
Specifications are subject to change without notice.
No reproduction allowed in any form without prior written
consent from Generac Power Systems, Inc.

GENERAC®

Generac Power Systems, Inc.
S45 W29290 Hwy. 59
Waukesha, WI 53189
1-888-GENERAC (1-888-436-3722)
www.generac.com