

ENGINE SYSTEM

- Mitsubishi® L3E-W461ML
- Diesel fueled
- EPA Tier 4
- 3 cylinder
- 0.95 L displacement
- ECOSpeed™ multi-speed operation
- Power @ 1,800 rpm – HP (kW):
 - Prime: 10.5 (7.83)
 - Standby: 12.2 (9.10)
- Air filter: Dry-type cartridge

Fuel System

- Tank usable capacity: 104.0 gal (393.68 L)
- Fuel consumption – gph (Lph):
 - Lights only: 0.195 (.738)*
 - 100% load: 0.594 (2.249)*
- Run time – hr:
 - Lights only: 530*
 - 100% load: 174*
- Exterior fill port diameter: 3.5 in (88.9 mm)
- Low fuel indicator beacon
- 100% containment

Cooling System

- Liquid cooled
- 100% containment

Lubrication System

- Oil filter: Full flow, spin-on type
- 1,000-hr service interval**

**Data based on engine manufacturer and field test data after 100-hr engine break-in period. Actual results may vary, according to factors such as age and maintenance of equipment, environmental conditions, and fuel density. For fuel and maintenance recommendations, see owner's manual.*

***For maximum service interval, replace oil filter after 50-hr break-in period. For oil filter model number, see owner's manual.*

GENERATOR

- 60 Hz engine/generator
- Marathon Electric® brushless
- Up to 6 kW output
- 120/240 VAC, 50/25 A
- ± 1% automatic voltage regulation



Picture shown may not reflect actual configuration.

CONTROLS

- Power Zone® Autolight controller
- One-touch or automated ignition
 - Automated ignition: Dusk-to-dawn or 7-day schedule
- ON-OFF switch for each light fixture
- Back-lit LCD display -40 °F/C rated heated display
- Programmable service timers – fuel filter, air filter, and engine oil
- Alarms and warnings
- Electrical trip or shutdown upon fault condition

FLOODLIGHTS

- Four 320 W LED fixtures
 - Lm/fixture: 47,000
 - Total lm: 188,000
- Efficiency: 147 lpw
- Coverage at 0.5 ft-c: 25,068 ft² (2,328 m²)
- IP68 LED modules; IP65 rated drivers
- Aluminum and polymer housing
- Fixture-mounted drivers
- 240 VAC mast cord and fixtures

Illumination Data

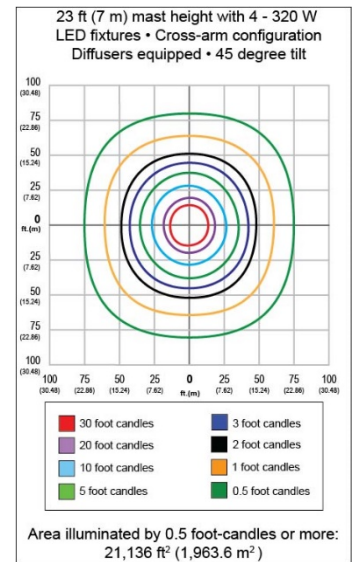
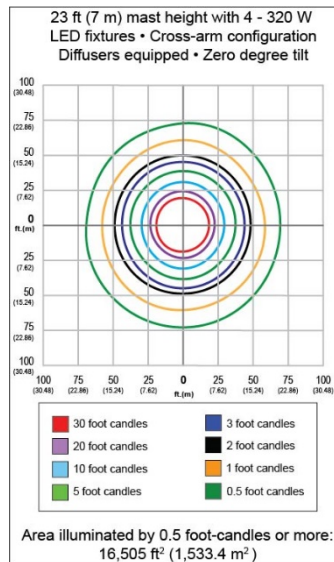
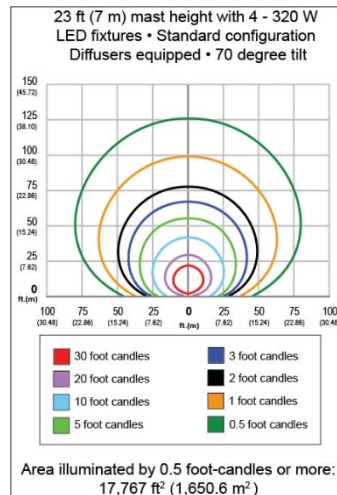
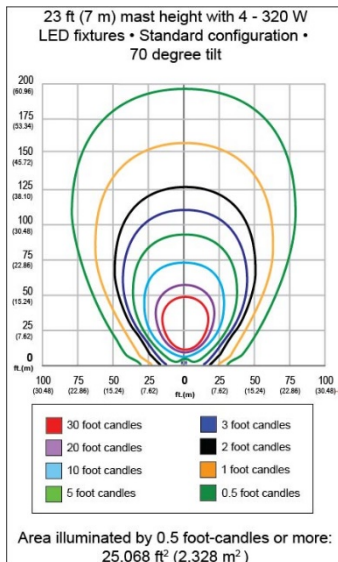

ELECTRICAL SYSTEM

- 30 A main breaker with auxiliary speed control
- Dual floodlight switch circuits with 5 A breakers
- Convenience receptacles with individual breakers:
 - Two 120 VAC, 20 A, GFCI, duplex outlets (NEMA 5-20R type)
 - One 240 VAC, 30 A, twistlock outlets (NEMA L6-30R type)
- One 440 CCA battery

MAST

- Vertical operation and storage
- Four tubular steel sections with polymer guides
- Winch: Dual handle, manual crank, self-braking
- 359° rotation – lockable and adjustable from ground with mast fully extended
- Dual handle manual winch

- Industrial black powder coat
- Self-retracting, coiled power cord

ENCLOSURE

- Aluminum - .080" 5052
- UV & fade resistant, high temperature cured, white polyester powder paint
- Sound rating: 63 dB(A) @ 23 feet
- Central lifting point and fork pockets
- Multi-lingual operating and safety decals
- Illuminated license plate holder
- Document holder with owner's manual – includes AC and DC wiring diagrams

TRAILER

- Tubular steel frame, molded polyethylene fenders
- 2 in (50.8 mm) ball hitch with tandem tow receiver
- Four 2,000 lb (907 kg) leveling jacks
- Side outriggers
- 7,800 lb (3,538 kg) safety chains with spring-loaded safety hooks
- Transportation tie-downs
- DOT approved lights: Tail, side, brake, and directionals
- 3,000 lb (1,361 kg) leaf spring axle
- Tires: 15 in (38 cm), 6 ply

OPTIONS*

- Electric mast
- Diffuse LED fixtures
- Cold weather package options
- Canadian Package (CAN)
 - 60/40 coolant
 - Radiator hose heater
 - Heated fuel filter
 - 775 CCA AGM sealed battery
 - Liquid containment for fuel and coolant

**Additional options available. Please contact a sales representative or the factory for current options.*

DIMENSIONS

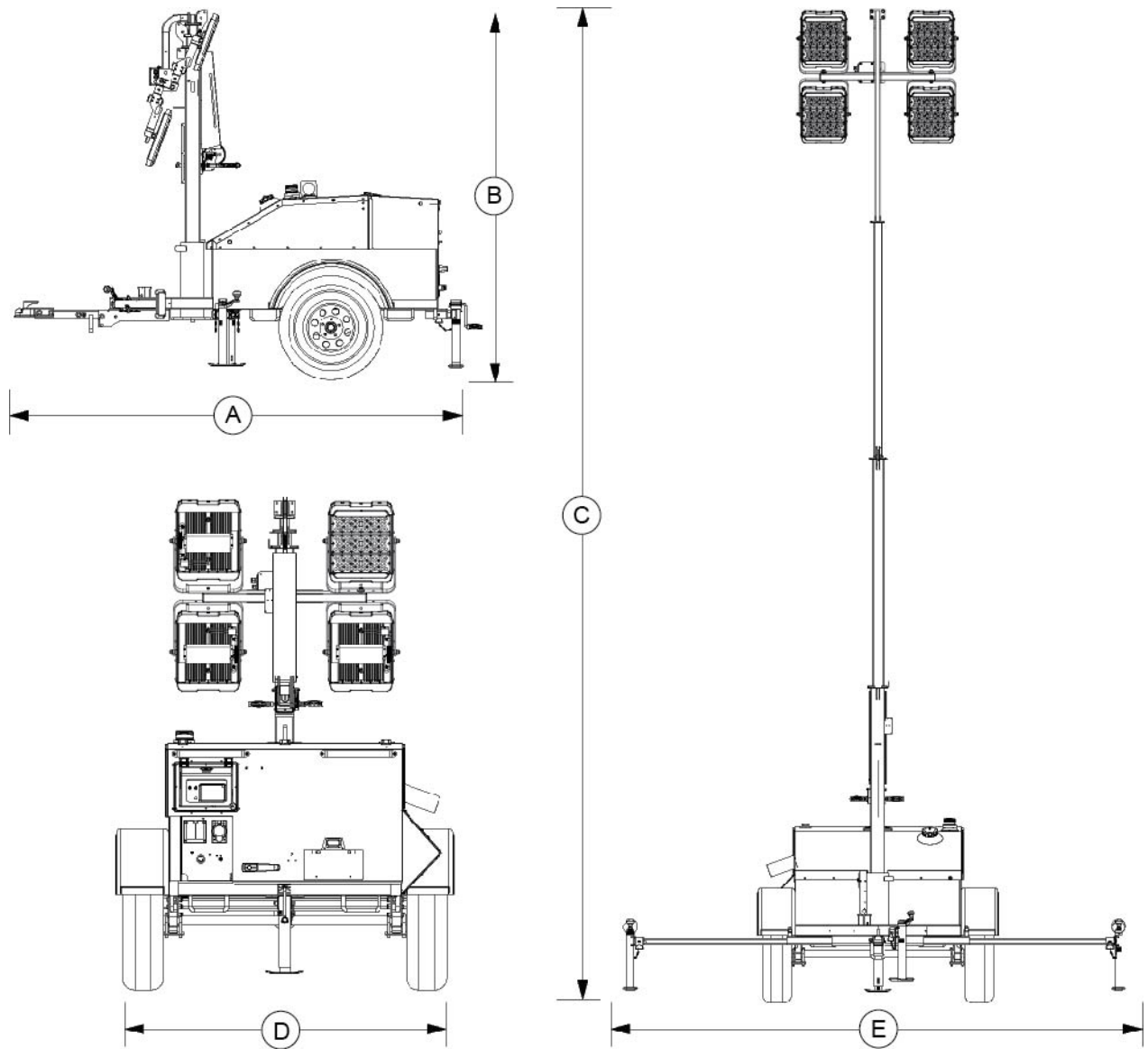

011371

A	B	C	D	E
10.4 ft (3.16 m)	8.4 ft (1.83 m)	23 ft (9.14 m)	5.7 ft (2 m)	12.07 ft (m)

WEIGHT

- Dry: 1,694 lb (768 kg)
- Operating: 2,770 lb (1256 kg)

AMBIENT CLIMATE RATINGS

- Maximum wind speed: 65 mph (105 km/h)
- Maximum air temperature: 113 °F (45 °C)

WARRANTY

- 1 year, unlimited hours/2 years, 2,000 hours
- 5 year limited warranty on LED modules and drivers

CERTIFICATIONS

CSA certified

MORE INFORMATION

Owner's manual is available at www.generacmobileproducts.com/resources-tools/manuals.