

Owner's Manual 60 Hz Air-Cooled Generators

7.5 kW PowerPact™

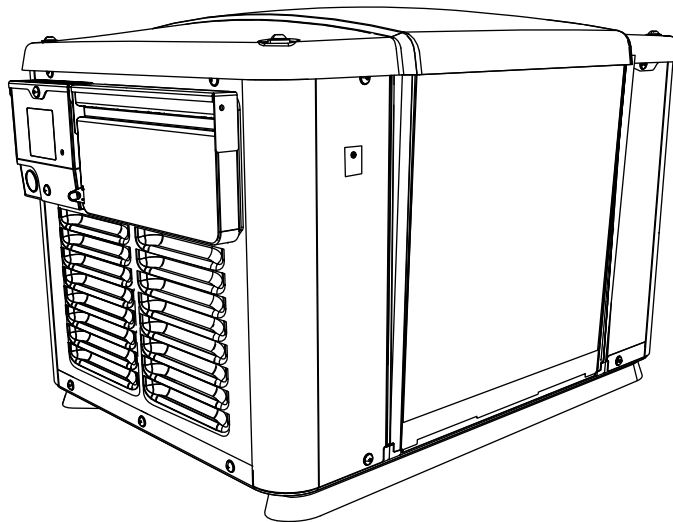

WARNING

Loss of life. This product is not intended to be used in a critical life support application. Failure to adhere to this warning could result in death or serious injury.

(000209b)

Register your Generac product at:
WWW.GENERAC.COM
1-888-GENERAC
(888-436-3722)

Para español , visita: <http://www.generac.com/service-support/product-support-lookup>

Pour le français, visiter : <http://www.generac.com/service-support/product-support-lookup>

SAVE THIS MANUAL FOR FUTURE REFERENCE

Use this page to record important information about your generator set.

Model:	
Serial:	
Prod Date Week:	
Volts:	
LPV Amps:	
NG Amps:	
Hz:	
Phase:	
Controller P/N:	

Record the information found on your unit data label on this page. The unit has a label plate affixed to the inside partition, above the battery access panel as shown in **Figure 2-1**. For directions on how to open the top lid and remove the front panel, see the Owner's Manual.

When contacting an Independent Authorized Service Dealer (IASD) about parts and service, always supply the complete model number and serial number of the unit.

Operation and Maintenance: Proper maintenance and care of the generator ensures a minimum number of problems and keeps operating expenses at a minimum. It is the operator's responsibility to perform all safety checks, to make sure that all maintenance for safe operation is performed promptly. Generac recommends that the equipment be checked periodically by an IASD. Normal maintenance, service and replacement of parts are the responsibility of the owner/operator and, as such, are not considered defects in materials or workmanship within the terms of the warranty. Individual operating habits and usage may contribute to the need for additional maintenance or service.

When the generator requires servicing or repairs, Generac recommends contacting an IASD for assistance. Authorized service technicians are factory-trained and are capable of handling all service needs. To locate the nearest IASD, please visit the dealer locator at:

www.generac.com/Service/DealerLocator/

 WARNING

Operating, servicing and maintaining this equipment can expose you to chemicals including engine exhaust, carbon monoxide, phthalates, and lead, which are known to the State of California to cause cancer and birth defects or other reproductive harm. To minimize exposure, avoid breathing exhaust, do not idle the engine except as necessary, service your equipment in a well-ventilated area and wear gloves or wash your hands frequently when servicing your equipment.

For more information go to www.P65Warnings.ca.gov.

(000393)

Table of Contents

Section 1: Safety Information

Introduction	1
Read This Manual Thoroughly	1
How to Obtain Service	1
Safety Rules	2
General Hazards	2
Exhaust Hazards	3
Electrical Hazards	3
Fire Hazards	4
Explosion Hazards	4

Section 2: General Information

The Generator	5
Data Decals	7
Protection Systems	8
Emissions	8
Fuel Requirements	8
Battery Requirements	8
Battery Charger	8
Engine Oil Requirements	8

Section 3: Operation

Site Prep Verification	11
Controller Lid	11
Main Line Circuit Breaker (Generator Disconnect)	11
Control Panel	12
Alarm Response Procedures	13
Clearing an Alarm/Warning Condition	13
Setting the Exercise Timer	13
Battery Charger	13
Manual Transfer Operation	13
Transfer to Generator Power Source	13
Transfer Back to Utility Power Source	14
Automatic Transfer Operation	14
Automatic Sequence of Operation	15
Utility Failure	15
Cranking	15
Cold Smart Start	15
Load Transfer	15

Shutting Generator Down While Under Load Or During A Utility Outage	15
Auxiliary Shutdown Switch	16

Section 4: Maintenance

Maintenance	17
Performing Scheduled Maintenance	17
Clearing a Maintenance Due Condition	17
Service Schedule	18
Checking Engine Oil Level	20
Engine Oil Recommendations	20
Changing the Oil	21
Changing the Engine Air Cleaner	21
Spark Plug	22
Valve Clearance Adjustment	22
Check Valve Clearance	22
Adjust Valve Clearance	22
Battery Maintenance	23
Attention After Submersion	24
Corrosion Protection	24
Remove From, and Return To Service Procedure	24
Remove From Service	24
Return to Service	24

Section 5: Troubleshooting

Section 6: Quick Reference Guide

System Diagnosis	27
-------------------------------	----

This page intentionally left blank.

Section 1: Safety Information

Introduction

Thank you for purchasing this compact, high performance, air-cooled, engine-driven generator. It is designed to automatically supply electrical power to operate critical loads during a utility power failure.

This unit is factory installed in an all-weather, metal enclosure intended exclusively for outdoor installation. This generator will operate using either vapor withdrawn liquid propane (LP) or natural gas (NG).

NOTE: When sized properly, this generator is suitable for supplying typical residential loads such as induction motors (sump pumps, refrigerators, air conditioners, furnaces, etc.), electronic components (computer, monitor, TV, etc.), lighting loads and microwaves.

Read This Manual Thoroughly



Consult Manual. Read and understand manual completely before using product. Failure to completely understand manual and product could result in death or serious injury. (000100a)

If any portion of this manual is not understood, contact the nearest Independent Authorized Service Dealer (IASD) for starting, operating and servicing procedures.

This manual must be used in conjunction with the appropriate Installation Manual.

SAVE THESE INSTRUCTIONS: The manufacturer suggests that this manual and the rules for safe operation be copied and posted near the unit installation site. Safety should be stressed to all operators and potential operators of this equipment.

The information in this manual is accurate based on products produced at the time of publication. The manufacturer reserves the right to make technical updates, corrections, and product revisions at any time without notice.

Safety Messages

Throughout this publication and on tags and decals affixed to the generator, DANGER, WARNING, and CAUTION blocks are used to alert personnel to special instructions about a particular operation that may be hazardous if performed incorrectly or carelessly. Observe them carefully. Their definitions are as follows:



Indicates a hazardous situation which, if not avoided, will result in death or serious injury.

(000001)



Indicates a hazardous situation which, if not avoided, could result in death or serious injury.

(000002)



Indicates a hazardous situation which, if not avoided, could result in minor or moderate injury.

(000003)

NOTE: Notes provide additional information important to a procedure or component.

These safety alerts cannot eliminate the hazards they indicate. Observing safety precautions and strict compliance with the special instructions while performing the action or service are essential to preventing accidents.

The operator is responsible for proper and safe use of the equipment. The manufacturer strongly recommends that if the operator is also the owner, to read the Owner's Manual and thoroughly understand all instructions before using this equipment. The manufacturer also strongly recommends instructing other users to properly start and operate the unit. This prepares them if they need to operate the equipment in an emergency.

How to Obtain Service

When the generator requires servicing or repairs, Generac recommends contacting an IASD for assistance. Service technicians are factory-trained and are capable of handling all service needs. For assistance locating an IASD, go to www.generac.com/Service/DealerLocator/.

When contacting an IASD about parts and service, always supply the complete model number and serial number of the unit as given on its data decal, which is located on the generator. Refer to [Figure 2-1](#) for decal location. Record the model number and serial numbers in the spaces provided on the inside front cover of this manual.

Safety Rules

Study these SAFETY RULES carefully before installing, operating or servicing this equipment. Become familiar with this Owner's Manual and with the unit. The generator can operate safely, efficiently and reliably only if it is properly installed, operated and maintained. Many accidents are caused by failing to follow simple and fundamental rules or precautions.

The manufacturer cannot anticipate every possible circumstance that might involve a hazard. The warnings in this manual and on tags and decals affixed to the unit are, therefore, not all-inclusive. If using a procedure, work method, or operating technique the manufacturer does not specifically recommend, verify that it is safe for others. Also, make sure the procedure, work method or operating technique utilized does not render the generator unsafe.

General Hazards

⚠ DANGER

Loss of life. Property damage. Installation must always comply with applicable codes, standards, laws and regulations. Failure to do so will result in death or serious injury. (000190)

⚠ DANGER

Automatic start-up. Disconnect utility power and render unit inoperable before working on unit. Failure to do so will result in death or serious injury. (000191)



⚠ WARNING

Loss of life. This product is not intended to be used in a critical life support application. Failure to adhere to this warning could result in death or serious injury. (000209b)

⚠ WARNING

Equipment damage. This unit is not intended for use as a prime power source. It is intended for use as an intermediate power supply in the event of temporary power outage only. Doing so could result in death, serious injury, and equipment damage. (000247a)



⚠ WARNING

Electrocution. Potentially lethal voltages are generated by this equipment. Render the equipment safe before attempting repairs or maintenance. Failure to do so could result in death or serious injury. (000187)

⚠ WARNING

Accidental Start-up. Disconnect the negative battery cable, then the positive battery cable when working on unit. Failure to do so could result in death or serious injury. (000130)

⚠ WARNING

Equipment damage. Only qualified service personnel may install, operate, and maintain this equipment. Failure to follow proper installation requirements could result in death, serious injury, and equipment or property damage. (000182a)

⚠ WARNING

Electric shock. Only a trained and licensed electrician should perform wiring and connections to unit. Failure to follow proper installation requirements could result in death, serious injury, and equipment or property damage. (000155a)



⚠ WARNING

Moving Parts. Do not wear jewelry when starting or operating this product. Wearing jewelry while starting or operating this product could result in death or serious injury. (000115)



⚠ WARNING

Moving Parts. Keep clothing, hair, and appendages away from moving parts. Failure to do so could result in death or serious injury. (000111)



⚠ WARNING

Hot Surfaces. When operating machine, do not touch hot surfaces. Keep machine away from combustibles during use. Hot surfaces could result in severe burns or fire. (000108)

⚠ WARNING

Equipment and property damage. Do not alter construction of, installation, or block ventilation for generator. Failure to do so could result in unsafe operation or damage to the generator. (000146)

⚠ WARNING

Risk of injury. Do not operate or service this machine if not fully alert. Fatigue can impair the ability to service this equipment and could result in death or serious injury.

(000215)

⚠ WARNING

Injury and equipment damage. Do not use generator as a step. Doing so could result in falling, damaged parts, unsafe equipment operation, and could result in death or serious injury.

(000216)

Inspect the generator regularly. Generac recommends contacting the nearest Independent Authorized Service Dealer for parts needing repair or replacement.

Exhaust Hazards



⚠ DANGER

Asphyxiation. Running engines produce carbon monoxide, a colorless, odorless, poisonous gas. Carbon monoxide, if not avoided, will result in death or serious injury.

(000103)



⚠ WARNING

Asphyxiation. Always use a battery operated carbon monoxide alarm indoors and installed according to the manufacturer's instructions. Failure to do so could result in death or serious injury.

(000178a)

- Adequate, unobstructed flow of cooling and ventilating air is critical to correct generator operation. Do not alter the installation or permit even partial blockage of ventilation provisions, as this can seriously affect safe operation of the generator. The generator must be installed and operated outdoors only.

Electrical Hazards



⚠ DANGER

Electrocution. Contact with bare wires, terminals, and connections while generator is running will result in death or serious injury.

(000144)



⚠ DANGER

Electrocution. Never connect this unit to the electrical system of any building unless a licensed electrician has installed an approved transfer switch. Failure to do so will result in death or serious injury.

(000150)

⚠ DANGER

Electrical backfeed. Use only approved switchgear to isolate generator from the normal power source. Failure to do so will result in death, serious injury, and equipment damage.

(000237)



⚠ DANGER

Electrocution. Verify electrical system is properly grounded before applying power. Failure to do so will result in death or serious injury.

(000152)



⚠ DANGER

Electrocution. Do not wear jewelry while working on this equipment. Doing so will result in death or serious injury.

(000188)



⚠ DANGER

Electrocution. Water contact with a power source, if not avoided, will result in death or serious injury.

(000104)



⚠ DANGER

Electrocution. Contact with bare wires, terminals, and connections while generator is running will result in death or serious injury.

(000144)



⚠ DANGER

Electrocution. In the event of electrical accident, immediately shut power OFF. Use non-conductive implements to free victim from live conductor. Apply first aid and get medical help. Failure to do so will result in death or serious injury.

(000145)

Fire Hazards



⚠️ WARNING

Fire hazard. Do not obstruct cooling and ventilating airflow around the generator. Inadequate ventilation could result in fire hazard, possible equipment damage, death or serious injury. (000217)



⚠️ WARNING

Fire and explosion. Installation must comply with all local, state, and national electrical building codes. Noncompliance could result in unsafe operation, equipment damage, death or serious injury. (000218)



⚠️ WARNING

Fire hazard. Use only fully-charged fire extinguishers rated “ABC” by the NFPA. Discharged or improperly rated fire extinguishers will not extinguish electrical fires in automatic standby generators. (000219)



⚠️ WARNING

Consult Manual. Read and understand manual completely before using product. Failure to completely understand manual and product could result in death or serious injury. (000100a)



⚠️ WARNING

Electrocution. Refer to local codes and standards for safety equipment required when working with a live electrical system. Failure to use required safety equipment could result in death or serious injury. (000257)



⚠️ WARNING

Risk of Fire. Unit must be positioned in a manner that prevents combustible material accumulation underneath. Failure to do so could result in death or serious injury. (000147)

Comply with regulations the Occupational Safety and Health Administration (OSHA) has established. Also, verify that the generator is installed in accordance with the manufacturer’s instructions and recommendations. Following proper installation, do nothing that might alter a safe installation and render the unit in noncompliance with the aforementioned codes, standards, laws and regulations.

Explosion Hazards



⚠️ DANGER

Explosion and fire. Fuel and vapors are extremely flammable and explosive. No leakage of fuel is permitted. Keep fire and spark away. Failure to do so will result in death or serious injury. (000192)

⚠️ DANGER

Explosion and fire. Connection of fuel source must be completed by a qualified professional technician or contractor. Incorrect installation of this unit will result in death, serious injury, and property and equipment damage. (000151a)



⚠️ DANGER

Risk of fire. Allow fuel spills to completely dry before starting engine. Failure to do so will result in death or serious injury. (000174)



⚠️ WARNING

Risk of Fire. Hot surfaces could ignite combustibles, resulting in fire. Fire could result in death or serious injury. (000110)

Section 2: General Information

The Generator

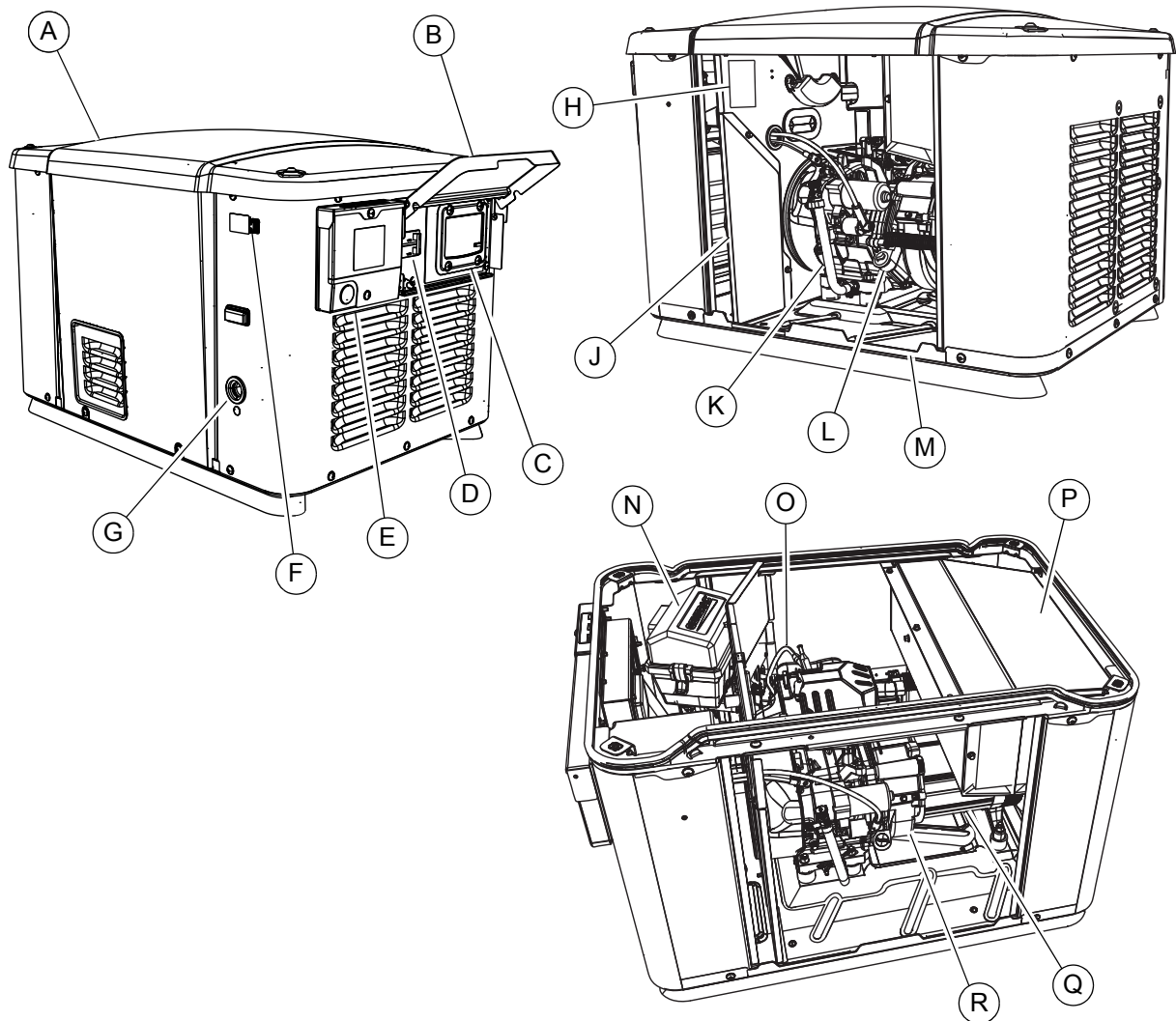

005568

Figure 2-1. Features and Components

- | | | |
|-------------------------------------|----------------------------|----------------------|
| A. Top Lid | G. Fuel Connection Hole | N. Air Box |
| B. Controller Lid | H. Data Label | O. Spark Plug |
| C. Control Panel | J. Battery Access Panel | P. Exhaust Enclosure |
| D. Circuit Breaker | K. Oil Drain Hose | Q. Alternator |
| E. Customer Connection Box | L. Oil Fill / Dipstick | R. Starter Motor |
| F. Auxiliary Engine Shutdown Switch | M. Front Panel (not shown) | |

Specifications

Generator

Model	7.5 kW
Rated Voltage	240
Rated Maximum Load Current (Amps) at Rated Volts (LP)*	31.25
Main Line Circuit Breaker (Generator Disconnect)	35 Amp
Phase	1
Rated AC Frequency	60 Hz
Battery Requirement	Group U1, 12 Volts and 300 CCA Minimum (see Replacement Parts)
Enclosure	Galvanneal Steel
Unit Weight	280 lb (127.3 kg)
Normal Operating Range	This unit is tested in accordance to UL 2200 standards with an operating temperature of -20 °F (-29 °C) to 122 °F (50 °C). For areas where temperatures fall below 32 °F (0 °C) a cold weather kit is recommended. When operated above 77 °F (25 °C) there may be a decrease in engine power. (Please reference the engine specifications section.)
<p>These generators are rated in accordance with UL 2200, Safety Standard for Stationary Engine Generator Assemblies, and CSA-C22.2 No. 100-04 Standard for Motors and Generators.</p> <p>* Natural Gas ratings will depend on specific fuel joules/Btu content. Typical derates are between 10-20% off the LP gas rating.</p> <p>** Circuits to be moved must be protected by same size breaker. For example, a 15 amp circuit in the main panel must be a 15 amp circuit in the transfer switch.</p>	



Engine

Model	7.5 kW
Type of Engine	GA-420
Number of Cylinders	1
Displacement	25.6 in ³ (420 cc)
Cylinder Block	Aluminum w/ cast iron sleeve
Recommended Spark Plug	see Replacement Parts
Spark Plug Gap	0.030 in (0.76 mm)
Valve Clearance	0.002 - 0.004 in (0.05 - 0.1 mm)
Starter	12 VDC
Oil Capacity	Approx. 1.2 qt (1.1 L)
Recommended Air Filter	see Replacement Parts
<p>Engine power is subject to and limited by such factors as fuel Btu/joules, ambient temperature and altitude. Engine power decreases about 3.5 percent for each 1000 feet (304.8 meters) above sea level, and also will decrease about 1 percent for each 10 °F (6 °C) above 60 °F (15 °C) ambient temperature.</p>	

A detailed specification sheet for your particular generator is available from your local Independent Authorized Service Dealer (IASD).

Data Decals

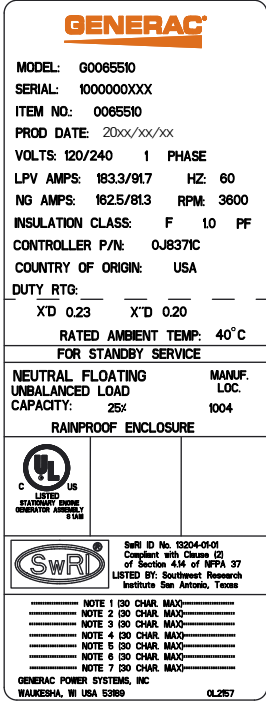
Two decals on the generator provide information about the unit itself and the required fuel inlet pressure for proper operation.

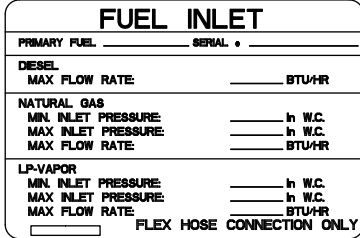
 <p>GENERAC</p> <p>MODEL: G0065510 SERIAL: 1000000XXX ITEM NO: 0065510 PROD DATE: 20xx/xx/xx VOLTS: 120/240 1 PHASE LPV AMPS: 183.3/91.7 HZ: 60 NG AMPS: 162.5/81.3 RPM: 3600 INSULATION CLASS: F 10 PF CONTROLLER P/N: OJB371C COUNTRY OF ORIGIN: USA DUTY RTG: _____ X'D 0.23 X'D 0.20 RATED AMBIENT TEMP: 40°C FOR STANDBY SERVICE</p> <p>NEUTRAL FLOATING UNBALANCED LOAD CAPACITY: 25% 1004</p> <p>RAINPROOF ENCLOSURE</p> <p> LISTED STATISTICAL SOURCE GENERATOR ASSEMBLY & LAB</p> <p> SwRI ID No. 13204-08-01 Compliant with Class 02 of Section 4.14 of NFPA 37 LISTED BY: Southwest Research Institute San Antonio, Texas</p> <p>NOTE 1 (30 CHAR. MAX) _____ NOTE 2 (30 CHAR. MAX) _____ NOTE 3 (30 CHAR. MAX) _____ NOTE 4 (30 CHAR. MAX) _____ NOTE 5 (30 CHAR. MAX) _____ NOTE 6 (30 CHAR. MAX) _____ NOTE 7 (30 CHAR. MAX) _____</p> <p>GENERAC POWER SYSTEMS, INC. WALKERSHA, WI USA 53089 0L267</p>	<h3>Model Data Decal</h3> <p>Includes important information about the unit including:</p> <ul style="list-style-type: none"> • model number • serial number • production date • voltage • frequency • amps • country of origin • rated ambient temperature. <p>The model data decal also displays certification symbols by Underwriter's Laboratory (UL) and the Southwest Research Institute (SwRI).</p>
 <p>FUEL INLET</p> <p>PRIMARY FUEL _____ SERIAL # _____</p> <p>DIESEL MAX FLOW RATE: _____ BTU/HR</p> <p>NATURAL GAS MIN. INLET PRESSURE: _____ in W.C. MAX INLET PRESSURE: _____ in W.C. MAX FLOW RATE: _____ BTU/HR</p> <p>LP-VAPOR MIN. INLET PRESSURE: _____ in W.C. MAX INLET PRESSURE: _____ in W.C. MAX FLOW RATE: _____ BTU/HR</p> <p>_____ FLEX HOSE CONNECTION ONLY</p>	<h3>Fuel Inlet Pressure</h3> <p>Displays the unit serial number, along with the minimum and maximum inlet pressures for natural gas (NG) and liquid propane (LP) supply. Space is provided for the installer to enter maximum flow rates based on installed pipe sizes and lengths.</p>

Protection Systems

The generator may have to run for long periods of time with no operator present to monitor the engine/generator conditions. Therefore, the generator is equipped with a number of systems to automatically shut down the unit to protect it against potentially damaging conditions. Some of these systems are as follows:

- Low Oil Level Sensor
- High Temperature Sensor
- Overcrank Detection
- Overspeed Detection
- RPM Sensor
- Underspeed Detection
- Charger Problem Detection
- Battery Problem Detection
- Fuse Problem Detection (missing or failed)
- Wiring Error Detection

The control panel contains LEDs which alert the operator when a fault condition occurs. The above list is not all inclusive. For more information about alarms and control panel operation, see Section 3 [Operation](#).

Emissions

The United States Environmental Protection Agency (US EPA) (and California Air Resources Board (CARB), for engines/equipment certified to California standards) requires that this engine/equipment complies with exhaust and evaporative emissions standards. Locate the emissions compliance decal on the engine to determine applicable standards. For emissions warranty information, please reference the included emissions warranty. It is important to follow the maintenance specifications in the manual to ensure that the engine complies with the applicable emissions standards for the duration of the product's life.

This generator is certified to operate on Liquid Propane Vapor fuel or pipeline Natural Gas.

The Emission Control System code is EM (Engine Modification). The Emission Control System on this generator consists of the following:

System	Components
Air Induction	- Airbox Assembly - Air Cleaner
Fuel Metering	- Carburetor / Mixer Assembly - Fuel Regulator - Fuel Jet
Ignition	- Spark Plug - Ignition Module
Exhaust	- Exhaust Manifold - Muffler - Muffler System

Fuel Requirements



⚠ DANGER

Explosion and Fire. Fuel and vapors are extremely flammable and explosive. Add fuel in a well ventilated area. Keep fire and spark away. Failure to do so will result in death or serious injury. (000105)

The engine has been fitted with a dual fuel carburetion system. The unit will run on natural gas or LP gas (vapor), but it has been factory set to run on natural gas. The fuel system will be configured for the available fuel source during installation.

Recommended fuels should have a BTU content of at least 1000 BTUs per cubic foot (37.26 megajoules per cubic meter) for natural gas, or at least 2500 BTUs per cubic foot (93.15 megajoules per cubic meter) for LP gas (vapor).

NOTE: If converting to LP gas from natural gas, consult with your local LP fuel provider to properly size the generator fuel tank. See the Installation Manual for complete procedures and details.

Battery Requirements

Group U1, 12V, minimum 300 CCA.

For proper battery maintenance procedures, see Section 4 [Maintenance](#).

Battery Charger

The battery charger is integrated into the control panel module in all models. It operates as a Smart Charger which ensures output charging levels are safe and continuously optimized to promote maximum battery life.

Engine Oil Requirements

For proper oil viscosity, see chart in [Figure 4-2](#).

Replacement Parts

Description	7.5 kW
U1 Exide Battery	0J5584
Spark Plug	0L3059
Air Filter	0E9371A
Control Panel Fuse (7.5 Amp)	0D7178T
Transfer Switch Fuses	Refer to Transfer Switch Owner's Manual for part number

Accessories

Performance enhancing accessories are available for air-cooled generators.

Accessory	Description
Cold Weather Kit G006808-1	Recommended in areas where temperatures fall below 32 °F (0 °C).
Scheduled Maintenance Kit G006806-0	Includes all pieces necessary to perform maintenance on the generator along with oil recommendations.
Touch-Up Paint Kit G005703-0	Very important to maintain the look and integrity of the generator enclosure. This kit includes touch-up paint and instructions.
Wireless Local Monitor G006664-0	Completely wireless and battery powered, the Wireless Local Monitor provides you with instant status without ever leaving the house. Status lights (red, yellow and green) alert owners when the generator needs attention. Magnetic backing permits refrigerator mounting and gives a 600 foot (183 m) line of sight communication.
Wi-Fi LP Fuel Level Monitor G007005-0	The Wi-Fi enabled LP fuel level monitor provides constant monitoring of the connected LP fuel tank. Monitoring the LP fuel tank's fuel level is an important step in making sure your generator is ready to run during an unexpected power failure. Status alerts are available through a free application to notify when your LP tank is in need of a refill.
Extended Warranty Coverage (Available only in U.S. and Canada)	Extend your generator warranty coverage by purchasing extended warranty coverage. Covers both parts and labor. Extended coverage can be purchased within 12 months of the end-users purchase date. This extended coverage is applicable to registered units and end-user proof of purchase must be available upon request. Available for Generac®, Guardian® and PowerPact® products. Not available for Corepower™ and EcoGen™ products or all international purchases.

NOTE: Contact an IASD or visit www.generac.com for additional information on replacement parts, accessories, and extended warranties.

This page intentionally left blank.

Section 3: Operation

Site Prep Verification

It is important that the generator is installed in such a way that the airflow into and out of the generator is not impeded. Verify that all shrubs or tall grasses have been removed within 3 ft (0.91 m) of the intake and discharge louvers on the sides of the enclosure. It is also important that the generator is not subject to water intrusion. Verify that all potential sources such as water sprinklers, roof run-off, rain gutter down spouts and sump pump discharges are directed away from the generator enclosure.



WARNING

Risk of fire. Keep air inlet and exhaust areas free from leaves, grass, snow and other debris. Failure to do so could result in death, serious injury, property, and equipment damage. (000251)

DANGER

Automatic start-up. Disconnect utility power and render unit inoperable before working on unit. Failure to do so will result in death or serious injury. (000191)

Turn the generator OFF before performing maintenance. Remove 7.5 Amp fuse, T1 battery charge fuse from the transfer switch, and disconnect battery cables to prevent accidental start up. Disconnect the NEGATIVE (-) cable first, then disconnect the POSITIVE (+) cable. When connecting the cables, connect the POSITIVE cable first, the NEGATIVE cable last.

WARNING

Equipment damage. Only qualified service personnel may install, operate, and maintain this equipment. Failure to follow proper installation requirements could result in death, serious injury, and equipment or property damage. (000182a)

Controller Lid

To open or close the controller lid:

1. See view "A" in **Figure 3-1**. Lift lid from bottom to open. Lid will lock in place when raised.
2. See view "B" in **Figure 3-1**. Pull raised lid up and out slightly to unlock, then lower to close.

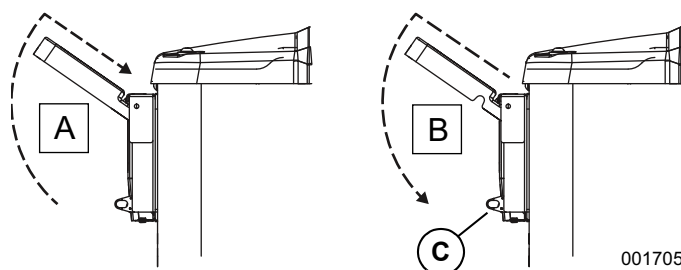

Figure 3-1. Open and Close Controller Lid

NOTE: Local codes may require this compartment to be locked. A hasp is provided so the owner/operator can secure the compartment with a padlock (C in **Figure 3-1**). Check local codes for side compartment locking requirements.

NOTE: All appropriate panels must be in place during any operation of the generator. This includes operation by a servicing technician while conducting troubleshooting procedures.

Main Line Circuit Breaker (Generator Disconnect)

The Main Line Circuit Breaker (MLCB) is located under the Controller Lid. Open the Controller Lid to access the circuit breaker (A in **Figure 3-2**).

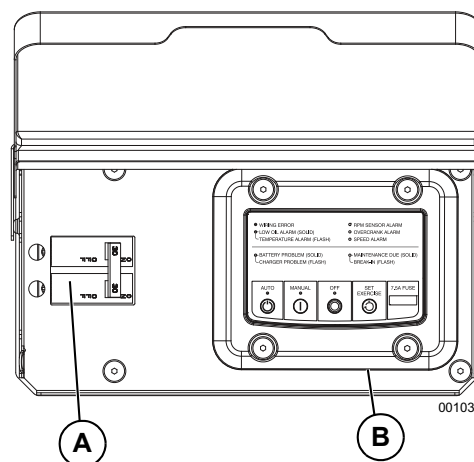

Figure 3-2. Control Panel and Circuit Breaker

Control Panel

The Control Panel is located under the Controller Lid. Open the Controller Lid to access the control panel (B in [Figure 3-2](#)).

The Auto/Off/Manual Interface located on the Control Panel has the following features (see [Figure 3-3](#)):

- Alarm LEDs (A)
- Warning LEDs (B)
- Operation Mode Buttons and LEDs (C)

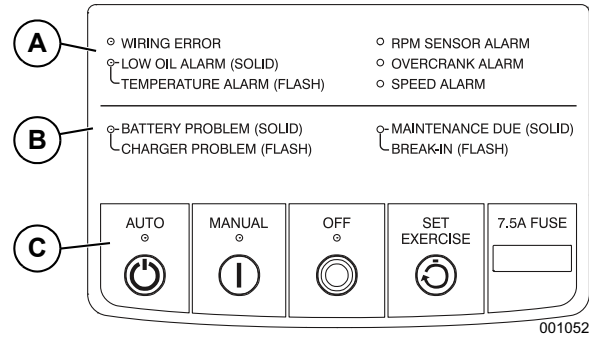

Figure 3-3. Generator Control Panel and LEDs

Using the Auto/Off/Manual Interface

Button	Description of Operation
AUTO (GREEN)	Selecting this button activates fully automatic system operation. It also allows the unit to automatically start and exercise the engine every seven days with the setting of the exercise timer (see Setting the Exercise Timer).
MANUAL (BLUE)	This button will crank and start the generator. Transfer to standby power will not occur unless there is a utility failure.
OFF (RED)	This button shuts down the engine and also prevents automatic operation of the unit.
SET EXERCISE (GREY)	Used to establish generator exercise time. Hold the button for 3 seconds at the new exercise time desired. NOTE: Exercise time can only be set at the time you wish exercise to actually take place.

NOTE: Transfer to generator power will cause either the AUTO (green), MANUAL (blue), or OFF (red) button to flash depending on which mode the generator is in at the time of utility loss.

Using the LED Interface

The user interface includes seven (7) LEDs to indicate generator alarms, warnings, and maintenance actions due. See [Figure 3-3](#) and the following table for details on each indication.

The user interface also includes 3-mode LEDs to indicate the current generator mode setting (AUTO, MANUAL, or OFF). The active LED is also used to indicate whether

the utility voltage is present. The active LED will be solid when utility is available. It will flash to indicate the loss of utility power. For example; when the generator is in AUTO and Utility is present, the green AUTO LED will be solid ON. When the generator is in AUTO and utility is lost, the AUTO LED will flash.

LED Alarm	Description (LED Flashing)	Description (LED Solid)
Temperature Alarm (Flashing)	Temperature levels are excessive	—
Low Oil Level Alarm (Solid) *	Auxiliary shutdown switch is OPEN (O).	Engine oil level is insufficient
Charger Warning (Flashing)	Charging problem exists	—
Battery Problem Warning (Solid) *	—	Battery problem exists
RPM Sensor Alarm	—	RPM sensor problem exists
Overcrank Alarm	—	Overcranking condition exists
Speed Alarm *	Overspeed condition exists	Underspeed condition exists
Break-in Maintenance Due (Flashing)	20 hour break-in maintenance due	—
Regular Maintenance Due (Solid) *	—	1 year / 100 hour maintenance due

* These LEDs are shared with multiple alarm conditions. Solid light indicates one alarm. Flashing light indicates the other alarm condition.

Alarm Response Procedures

The generator is protected by a series of sensors that will detect an Alarm/Warning condition and alert the owner/operator of the condition via the Control Panel display. When certain alarm conditions are detected, the generator will shut down.

NOTE: Unless properly trained to clear and correct Warning and Alarm conditions, contact the nearest IASD or Trained Technician.

Clearing an Alarm/Warning Condition

To clear an alarm or warning condition from the Control Panel, press the OFF button. Press OFF button again. The flashing or solid indicator LED will turn off.

LED Condition	Action	2nd Action	3rd Action
Clear Alarm / Warning or Maintenance LED Alarm(s)	press OFF	press OFF again	—
Clear Maintenance LED when Alarm or Warning LED is also present	press OFF	press OFF again	press OFF 3rd time

NOTE: Clearing a code will not correct the problem. It will simply turn off the LED indicating that told you that a problem occurred. The problem indicated must be diagnosed and corrected to prevent a re-occurring alarm condition.

NOTE: Removing or failure of the 7.5 Amp ATO® fuse will turn off all the panel LEDs. Replacement of the fuse will initiate the LED self test.

Setting the Exercise Timer

This generator is equipped with an exercise timer. Once it is set, the generator will start and exercise every seven days, on the day of the week and at the time of day this procedure was initiated. During this exercise period, the unit runs for approximately 12 minutes and then shuts down. Transfer of loads to the generator output does not occur during the exercise cycle unless utility power is lost.

1. Place the generator in the AUTO mode.
2. Hold the SET EXERCISE Button for 3 seconds. The generator will start, run an exercise cycle and confirm the setting.
3. The exercise time is now established. The generator will exercise each week at this time.

To CHANGE the exercise time once it has been set, hold the SET EXERCISE button on the generator for three (3) seconds at the time you wish the new exercise time to take place. The exercise timer does not correct for daylight savings time.

NOTE: The exerciser will only work in the AUTO mode and will default to exercise weekly at the time the Control Panel was last powered ON unless this procedure is performed. The exercise function will need to be reset every time the 12 volt battery and T1 power to the generator are disconnected and then reconnected, or when the fuse is removed and T1 power is removed from the generator, or both.

NOTE: If the unit is equipped with Mobile Link™, the exercise time can be remotely set for any desired day or time.

Battery Charger

NOTE: The battery charger is integrated into the control panel.

The battery charger operates as a Smart Charger that:

- verifies output is continually optimized to promote maximum battery life.
- verifies that charging levels are safe.

NOTE: Battery Problem LED is illuminated when the battery needs service.

Manual Transfer Operation



▲ DANGER

Electrocution. Do not manually transfer under load. Disconnect transfer switch from all power sources prior to manual transfer. Failure to do so will result in death or serious injury, and equipment damage. (000132)

Prior to automatic operation, manually exercise the transfer switch to verify that there is no interference with proper operation of the mechanism. Manual operation of the transfer switch is required if electronic operation should fail.

Transfer to Generator Power Source

1. Verify generator is in the OFF mode.
2. Set the main line circuit breaker (Generator Disconnect) to OFF or OPEN.
3. Turn off the utility power supply to the transfer switch using the means provided (such as a utility main line circuit breaker).
4. Use the manual transfer handle (A in [Figure 3-4](#)) inside the transfer switch to move the main contacts to the STANDBY position (loads connected to the standby power source, B in [Figure 3-4](#)).

5. To crank and start the engine, press the control panel MANUAL button.
6. Allow the engine to stabilize and warm up for a few minutes.
7. Set the main line circuit breaker (Generator Disconnect) to ON or CLOSED. The standby power source now powers the loads.

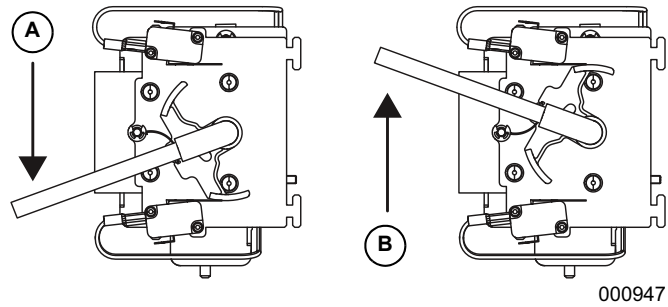

Figure 3-4. Manual Transfer Switch Operation

IMPORTANT NOTE: Actual switch operation may vary. Follow directions in the appropriate transfer switch manual.

MANUAL	<ul style="list-style-type: none"> • Will not transfer to generator if utility is present. • Will transfer to generator if utility fails (below 65% of nominal for 10 consecutive seconds). • Will transfer back when utility returns for 15 consecutive seconds. The engine will continue to run until removed from the MANUAL mode.
AUTO	<ul style="list-style-type: none"> • Will start and run if utility fails (below 65% of nominal for five consecutive seconds). • Will start a six second engine warm-up timer (or 30 seconds; refer to Cold Smart Start). <ul style="list-style-type: none"> –Will not transfer if utility subsequently returns. –Will transfer to generator if utility is not present. • Will transfer back to utility once utility returns (above 80% of nominal) for 15 seconds. • Will not transfer back to utility unless utility returns. The generator will shut down if the OFF button is pressed or a shutdown alarm is present. • Once utility power is returned, the generator will shut down after one minute cool-down time.
EXERCISE	<ul style="list-style-type: none"> • Will not exercise if generator is already running in either AUTO or MANUAL mode. • During exercise, the control panel will only transfer if utility fails during exercise for six seconds (or 30 seconds; refer to Cold Smart Start) and will operate as normal in AUTO mode.

Transfer Back to Utility Power Source

When utility power has been restored, transfer back to utility source and shut down the generator. To manually transfer back to utility power and shut down the generator:

1. Set the Main Line Circuit Breaker (Generator Disconnect) to OFF or OPEN.
2. Allow the engine to run for two minutes at no-load to stabilize the internal temperatures.
3. Press the control panel OFF button. The engine should shut down.
4. Verify that utility power supply to the transfer switch is turned off.
5. Use the manual transfer handle inside the transfer switch to move the main contacts back to the UTILITY position (loads connected to the utility power source, A in [Figure 3-4](#)).
6. Turn on the utility power supply to the transfer switch using the means provided.
7. Press the control panel AUTO button.

Automatic Transfer Operation

To select automatic operation:

1. Make sure the transfer switch main contacts are set to the UTILITY position (loads connected to the utility power source).
2. Verify that normal UTILITY power source voltage is available to transfer switch terminal lugs N1 and N2.
3. Press the AUTO button on the control panel interface.
4. Set the main circuit breaker (Generator Disconnect) to the ON (Closed) position.

With these steps complete, the generator will start automatically when utility source voltage drops below a preset level. After the unit starts, loads are transferred to the standby power source.

Automatic Sequence of Operation

Utility Failure

With the generator set to AUTO, when utility fails (below 65% of nominal) a five second line interrupt delay time is started. If utility is still gone when the timer expires, the engine will crank and start. Once started, a six second engine warm-up timer will be initiated (or a 30 second warm-up timer; refer to **Cold Smart Start**). When the warm-up time expires, the control panel will transfer the load to the generator. If the utility power is restored (above 80% nominal) at any time from the initiation of the engine start until the generator is ready to accept load (warm-up time has not elapsed), the control panel will complete the start cycle and run the generator through its normal cool down cycle, however, the load will remain on the utility source.

Cranking

The system will control cyclic cranking cycles as follows: 16 second crank, seven (7) second rest, 16 second crank, seven (7) second rest, followed by three (3) additional cycles of seven (7) second cranks followed by seven (7) second rests. An alarm will be triggered if the generator does not start after five attempts.

Cold Smart Start

The Cold Smart Start feature enables the generator to monitor ambient temperature. The warm-up delay will be adjusted based on prevailing conditions.

On a startup in AUTO mode, if the ambient temperature is below a fixed temperature (based on model) the generator will warm up for 30 seconds. This allows the engine to warm before a load is applied. If the ambient temperature is at or above the fixed temperature, the generator will start up with the normal warm-up delay of six seconds.

Load Transfer

The transfer of load when the generator is running is dependent upon the operating mode.

Shutting Generator Down While Under Load Or During A Utility Outage

⚠ DANGER

Automatic start-up. Disconnect utility power and render unit inoperable before working on unit. Failure to do so will result in death or serious injury.

(000191)

IMPORTANT NOTE: To avoid equipment damage, follow these steps, in order, during utility outages. Shutdowns may be required during utility outages to perform routine maintenance or to conserve fuel.

To turn the generator OFF:

1. Set the main utility disconnect to OFF (OPEN).
2. Set the generator MLCB (generator disconnect) to OFF (OPEN).
3. Allow the generator to run for a cool-down period of approximately one minute.
4. At the controller, set the generator to OFF.
5. Remove the 7.5A fuse from the controller.

To turn the generator back ON:

1. Install 7.5A fuse in controller.
2. Confirm the generator MLCB (generator disconnect) is OFF (OPEN).
3. At the controller, set the generator to AUTO mode.
4. Generator will start and run. Allow generator to run and warm up for a few minutes.
5. Set the MLCB (generator disconnect) to ON (CLOSED).
6. Set the main utility disconnect to ON (CLOSED).

The system now operates in automatic mode.

Auxiliary Shutdown Switch

All generators are provided with an external means to shut down the generator that complies with the 2017 NEC code requirement. The primary generator shutdown sequence is described in the previous topic.

See [Figure 3-5](#). An auxiliary shutdown switch is located on the exterior of the generator back panel. This switch shuts down the generator and disables restarts.

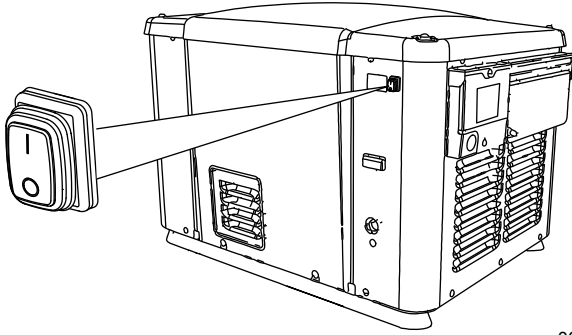

005570

Figure 3-5. Auxiliary Shutdown Switch

NOTE: Whenever possible, perform the primary shutdown procedure before disabling the generator with the auxiliary shutdown switch.

NOTE: If the auxiliary shutdown switch is open (O), the generator will not start. The controller displays a High Temperature alarm and the High Temperature LED on the controller flashes until the switch is closed (I). Once the switch is closed (I), the generator will return to either AUTO mode or OFF mode.

NOTE: The controller displays the same alarm message for either a High Temperature Alarm or an open auxiliary shutdown switch.

Section 4: Maintenance

Maintenance

Regular maintenance will improve performance and extend engine/equipment life. Generac Power Systems, Inc. recommends that all maintenance work be performed by an Independent Authorized Service Dealer (IASD). Regular maintenance, replacement or repair of the emissions control devices and systems may be performed by any repair shop or person of the owner's choosing. However, to obtain emissions control warranty service free of charge, the work must be performed by an IASD. See the emissions warranty.



Equipment damage. Only qualified service personnel may install, operate, and maintain this equipment. Failure to follow proper installation requirements could result in death, serious injury, and equipment or property damage.

(000182a)

Performing Scheduled Maintenance

It is important to perform maintenance as specified in the [Service Schedule](#) for proper generator operation and to verify that the generator complies with the applicable emission standards for the duration of its useful life. Service and repairs may be performed by any qualified service person or repair shop.

Additionally, emissions-critical maintenance must be performed as scheduled in order for the Emissions Warranty to be valid. Emissions-critical maintenance consists of servicing the air filter and spark plugs in accordance with the [Service Schedule](#). The Control Panel will prompt for break-in or regular maintenance, when it is required, to be performed. Break-in maintenance consists of the oil change, valve clearance and tune-up. Regular maintenance includes the oil, tune-up, air cleaner, spark plug and valve clearance.

NOTE: The control panel *Maintenance Due* light will flash when the initial 20 hour break-in interval has been reached. The same light will be lit solid when following regular maintenance intervals are required (every 1 year/100 hours).

Clearing a Maintenance Due Condition

After performing maintenance, the *Maintenance Due* light must be cleared. To reset the *Maintenance Due* light, the generator must be in OFF mode. Set the Generator to OFF and press the OFF button to reset *Maintenance Due*. If an alarm condition exists, the alarm condition must be cleared prior to resetting the *Maintenance Due* light.

Service Schedule

Table 4-1. Service Maintenance Schedule

System Component	Procedure			Frequency
X = Action * = Notify dealer if repair is needed	Inspect	Change	Clean	W = Weekly M = Monthly Y = Yearly
Fuel				
Fuel lines and connections	X			M
Lubrication				
Oil level	X			M or 24 hours of continuous operation
Oil		X		6 M or 100 hours of operation **
Enclosure louvers	X		X	W
Battery				
Remove corrosion; ensure dryness	X		X	Y
Clean and tighten battery terminals	X		X	Y
Check charge state	X	X		Y
Electrolyte level (unsealed batteries only)*	X	X		Every 6 M
Engine and mounting				
Air cleaner	X	X	X	3 M / 50 hours - clean 1 Y / 300 hours - replace
Spark plug	X	X		6 M or 100 hours - inspect 1 Y or 300 hours - change
Valve clearance	X			1 Y or 300 hours***
General condition				
Vibration, noise, leakage *	X			M
<p>Contact the nearest Independent Authorized Service Dealer for assistance if necessary.</p> <p>* Contact the nearest Independent Authorized Service Dealer for assistance if necessary.</p> <p>** Change oil after the first 20 hours of operation or 1 month. Continue to check at intervals of 100 hours or 6 months, whichever occurs first. Severe duty oil drain intervals: In cold weather conditions (ambient below 40 °F [4.4 °C]) change engine oil every 6 months or 50 hours of operation to prevent accumulation of water in the oil. If the unit will be operated continuously in hot ambient conditions (ambient above 85 °F [29.4 °C]) or operation in an extremely dusty or dirty environment change the engine oil every 3 months or 50 hours of operation to prevent oil breakdown.</p> <p>*** Check valve clearance after the first 20 hours of operation. Continue to check at intervals of 300 hours.</p>				

NOTE: Contact an Independent Authorized Service Dealer or visit www.generac.com for additional information on replacement parts.

Maintenance Log

Battery inspection and charge check

Dates Performed:

Oil, oil filter, air filter and spark plug replacement

Dates Performed:

Valve Adjustment

Dates Performed:

Notes:

Checking Engine Oil Level



⚠️ WARNING

Risk of burns. Allow engine to cool before draining oil or coolant. Failure to do so could result in death or serious injury.

(000139)

⚠️ WARNING

Skin irritation. Avoid prolonged or repeated contact with used motor oil. Used motor oil has been shown to cause skin cancer in laboratory animals. Thoroughly wash exposed areas with soap and water.

(000210)

⚠️ CAUTION

Engine damage. Verify proper type and quantity of engine oil prior to starting engine. Failure to do so could result in engine damage.

(000135)

When power outages necessitate running the generator for extended periods, the oil level should be checked daily. To check the engine oil level:

1. If the generator is running during a utility outage, turn OFF all associated loads running in the residence using the main utility disconnect.
2. Turn the generator main line circuit breaker (generator disconnect) to OFF.
3. Press the control panel OFF button.
4. Remove the 7.5 Amp fuse from the generator control panel.
5. Remove the enclosure top lid by unscrewing the fasteners, and lift the front panel off.
6. Remove the dipstick/fill cap and wipe it dry with a clean cloth.
7. Insert the dipstick/fill cap, but do not thread into the crankcase threads, then again remove it.
8. Verify oil level is within safe operating range. The level should be at the "H" mark on the dipstick/fill cap. See A in [Figure 4-1](#).

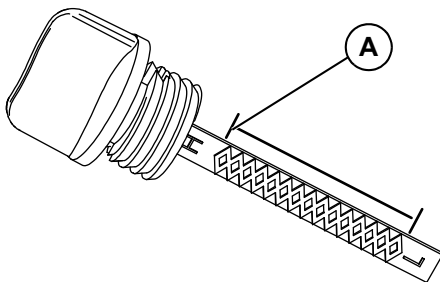

Figure 4-1. Safe Oil Operating Range

9. If necessary, remove the dipstick/fill cap and add oil to the engine until the level reaches the FULL mark and reinsert the dipstick and fill cap.
10. If the generator was running during a utility outage, turn the main circuit breaker to the ON position.
11. Install the 7.5 Amp fuse in the generator control panel.
12. Press the control panel AUTO button.
13. Turn ON the needed loads in the residence.

Engine Oil Recommendations

To maintain the product warranty, the engine oil should be serviced in accordance with the recommendations of this manual. For your convenience, Generac Maintenance Kits are available that include engine oil, oil filter, air filter, spark plug(s), a shop towel and funnel. These kits can be obtained from an IASD.

All Generac Maintenance kits meet minimum American Petroleum Institute (API) Service Class SJ, SL, or better. Use no special additives. Select the appropriate viscosity oil grade according to the expected operating temperature. Synthetic oil also can be used in the appropriate weight as standard.

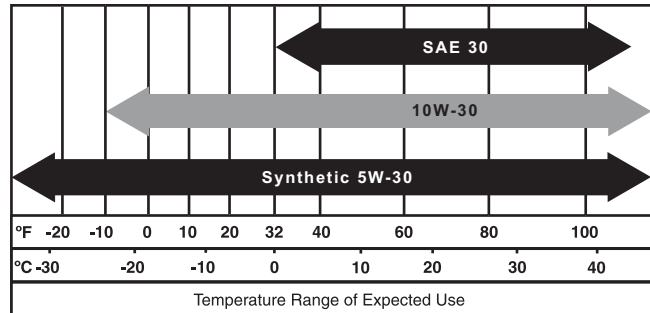

005799

Figure 4-2. Recommended Oil Based on Temperature

- SAE 30 above 32 °F (0 °C)
- SAE 10W-30 between -10 °F (4 °C) and above
- Synthetic SAE 5W-30 for all temperature ranges

⚠️ CAUTION

Engine damage. Verify proper type and quantity of engine oil prior to starting engine. Failure to do so could result in engine damage.

(000135)

Changing the Oil

WARNING

Skin irritation. Avoid prolonged or repeated contact with used motor oil. Used motor oil has been shown to cause skin cancer in laboratory animals. Thoroughly wash exposed areas with soap and water.

(000210)

1. Start the engine by pressing the MANUAL button on the control panel and allow the engine to run until it is thoroughly warmed up. Then, press the Control Panel OFF button to shut down the engine.
2. A few minutes after the engine shuts OFF, when it has cooled slightly, remove the enclosure top lid by unscrewing the fasteners, and lift the front panel off.
3. Remove the battery access panel (A) by loosening the two hex head screws. See [Figure 4-3](#).
4. Disconnect the battery and remove the fuse.
5. Pull the oil drain hose (B) free of its retaining clip (C). See [Figure 4-3](#).
6. Remove the cap from the hose and direct the hose into a suitable container.
7. Unscrew the drain hose cap and allow engine oil to drain. Remove dipstick/ fill plug to permit oil to drain faster. For proper drainage, drain the oil into a pan placed at a lower level than the engine.

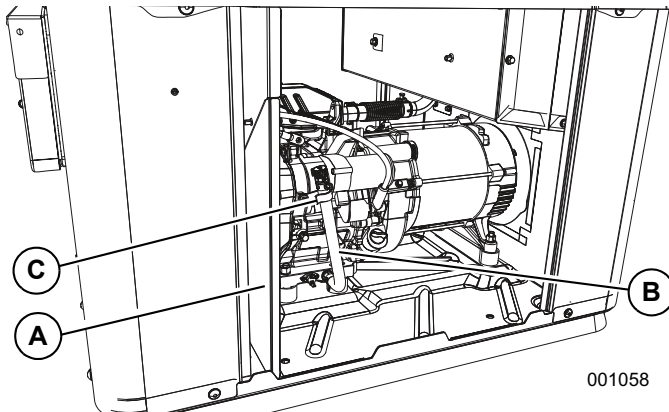

001058

Figure 4-3. Oil Drain Location

8. After the oil has drained, replace the cap onto the end of the oil drain hose. Reposition and secure the hose with the retaining clip.
9. Refill the engine with the proper recommended oil. For recommended oil, see [Figure 4-2](#).
10. Connect the battery, secure the battery access panel, insert the fuse, and switch the unit to MANUAL.
11. Start the engine, run for one minute, and check for leaks.
12. Shutdown the engine and check the oil level. Add oil as needed. **DO NOT OVERFILL.**

13. Insert dipstick/fill cap and hand tighten.
14. Press the Control Panel AUTO button.
15. Dispose of the used oil and filter at a proper collection center.

Changing the Engine Air Cleaner

1. With the generator shut down, remove the top lid.
2. See [Figure 4-4](#). Disengage the wire clip (A) and remove the air cleaner access cover (B).

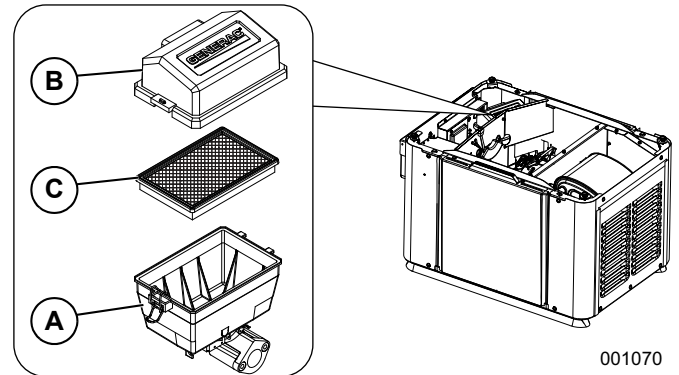

001070

Figure 4-4. Air Filter Location

3. Remove the old air filter (C) and discard.
4. Thoroughly clean the air cleaner enclosure of any dust or debris while ensuring that none of the debris falls in to the engine intake.
5. Install a new air filter.
6. Install the air cleaner cover and engage the wire clip.
7. Install the enclosure top lid. Tighten fasteners securely.
8. Place generator in AUTO.

Spark Plug

Check the spark plug gap and replace the spark plug as necessary:

1. With the generator shut down, remove the top lid.
2. Clean the area around the base of the spark plug to keep dirt and debris out of the engine.
3. Gently pull the spark plug boot off of the spark plug.
4. Remove the spark plug and check the condition. Install a new plug if the old plug is worn or if reuse is questionable.
5. Clean the plug by scraping or washing with a wire brush and commercial solvent. Do not blast the plug to clean.
6. See [Figure 4-5](#). Check the spark plug gap using a wire feeler gauge. The gap should measure 0.030 in (0.76 mm). If the gap is out of specification, replace the spark plug. See Section 2—[Replacement Parts](#).

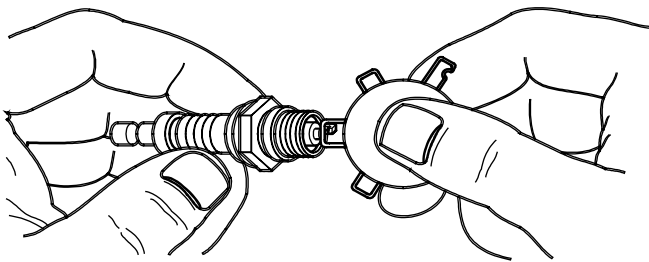

Figure 4-5. Spark Plug Gap Measurement

7. Install spark plug. Torque to 20–22 ft-lb (27–30 Nm).
8. Install spark plug boot.
9. Install the enclosure top lid. Tighten fasteners securely.

Valve Clearance Adjustment

Check the valve clearance after the first 20 hours of operation, then after 300 hour intervals. Adjust if necessary.

Important: Please contact an Independent Authorized Service Dealer for service assistance. This is a very important step to ensure longest life for the engine.

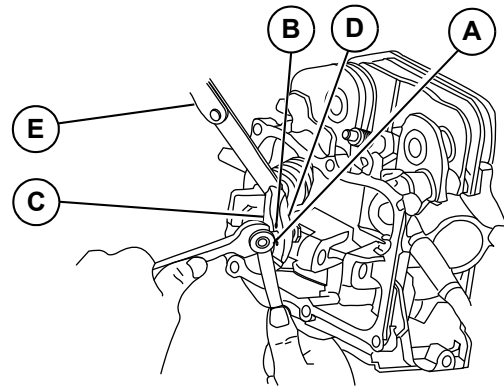

001071

Figure 4-6. Valve Clearance Adjustment

Check Valve Clearance

1. The engine should be cool before checking. Adjustment is not needed if valve clearance is within the specification in Section 2 — [Specifications](#).
2. Turn the generator OFF.
3. Remove enclosure lid fasteners and lid. Then remove the back panel.
4. Remove spark plug wire and position wire away from plug.
5. Remove spark plug.
6. Make sure the piston is at top dead center (TDC) of its compression stroke (both valves closed). To get the piston at TDC, remove the intake screen at the front of the engine to gain access to the flywheel nut. Use a large socket and socket wrench to rotate the nut and hence the engine in a clockwise direction. While watching the piston through the spark plug hole. The piston should move up and down. The piston is at TDC when it is at its highest point of travel.
7. See [Figure 4-6](#). Check clearance between the rocker arm (C) and the valve stem (D) with a feeler gauge (E).
8. If valve clearance is 0.002–0.004 in. (0.05–0.1 mm), adjustment is not needed.

Adjust Valve Clearance

See [Figure 4-6](#):

1. The engine should be cool before adjustment.
2. Remove enclosure lid fasteners and lid. Then remove the back panel (if not already removed).
3. Remove spark plug wire and position wire away from plug.
4. Remove spark plug.
5. Remove the four screws attaching the valve cover. Remove and discard gasket.
6. Loosen the rocker jam nut (A) using a 10mm wrench.

7. Turn the pivot ball stud (B) while checking clearance between the rocker arm (C) and the valve stem (D) with a feeler gauge (E). Correct clearance is 0.002–0.004 in. (0.05–0.1 mm).

NOTE: Hold the rocker arm jam nut in place as the pivot ball stud is turned.

8. When valve clearance is correct, hold the pivot ball stud in place with the wrench and tighten the rocker arm jam nut. Tighten the jam nut to 174 **in-lbs** (19.68 Nm) torque. After tightening the jam nut, recheck valve clearance to make sure it did not change.
9. Install new valve cover gasket.
10. Install the valve cover. Tighten fasteners in a cross pattern, torquing to 35–62 **in-lbs** (4–7 Nm).

NOTE: Start all four screws before tightening or it will not be possible to get all the screws in place. Make sure the valve cover gasket is in place.

11. Install the rubber plug into the fan screen.
12. Install the spark plug and attach the spark plug wire.
13. Install the back panel. Ensure that the alternator intake bellow is captured by the frame on back panel securely with out any kinks. Install enclosure top lid. Tighten all fasteners securely.
14. Place the generator in AUTO.

Battery Maintenance

The battery should be regularly inspected per the [Service Schedule](#):

1. With the generator shut down, lift the lid and remove the front panel and the battery access panel.
2. Inspect the battery posts and cables for tightness and corrosion. Tighten and clean as necessary.
3. Check the battery fluid level of unsealed batteries, and if necessary, fill with distilled water only. **DO NOT** use tap water. Also, have the Independent Authorized Service Dealer or a qualified Service Technician check the state of charge and condition.



⚠️ WARNING

Explosion. Do not dispose of batteries in a fire. Batteries are explosive. Electrolyte solution can cause burns and blindness. If electrolyte contacts skin or eyes, flush with water and seek immediate medical attention.

(000162)



⚠️ WARNING

Explosion. Batteries emit explosive gases while charging. Keep fire and spark away. Wear protective gear when working with batteries. Failure to do so could result in death or serious injury.

(000137a)



⚠️ WARNING

Electrical shock. Disconnect battery ground terminal before working on battery or battery wires. Failure to do so could result in death or serious injury.

(000164)



⚠️ WARNING

Risk of burns. Batteries contain sulfuric acid and can cause severe chemical burns. Wear protective gear when working with batteries. Failure to do so could result in death or serious injury.

(000138a)

⚠️ WARNING

Environmental Hazard. Always recycle batteries at an official recycling center in accordance with all local laws and regulations. Failure to do so could result in environmental damage, death or serious injury.

(000228)

Strictly observe the following precautions when working on batteries:

- Remove the 7.5 Amp fuse from the generator control panel.
- Remove all jewelry (watches, rings, metal objects, etc.)
- Use tools with insulated handles.
- Wear rubber gloves and boots.
- Do not place tools or metallic objects on top of the battery.
- Disconnect the charging source by pulling T1 fuse in the transfer switch prior to connecting or disconnecting battery terminals.
- Wear full eye protection and protective clothing.
- Where electrolyte contacts the skin, wash it off immediately with water.
- Where electrolyte contacts the eyes, flush thoroughly and immediately with water and seek medical attention.
- Wash down spilled electrolyte with an aid neutralizing agent. A common practice is to use a solution of 1 pound (500 grams) bicarbonate of soda to 1 gallon (4 liters) of water. The bicarbonate of soda solution is to be added until the evidence of reaction (foaming) has ceased. The resulting liquid is to be flushed with water and the area dried.
- **DO NOT** smoke when near the battery.
- **DO NOT** cause flame or spark in the battery area.
- Discharge static electricity from the body before touching the battery by first touching a grounded metal surface.

Always recycle batteries in accordance with local laws and regulations. Contact your local solid waste collection site or recycling facility to obtain information on local recycling processes. For more information on battery recycling, visit the Battery Council International website at: <http://batteryCouncil.org/>.

Attention After Submersion

If the generator has been submerged in water, it **MUST NOT** be started and operated. Following any submersion in water, have an Independent Authorized Service Dealer thoroughly clean, dry, and inspect the generator. If the structure (home) has been flooded, it should be inspected by a certified electrician to verify there won't be any electrical problems during generator operation or when utility power is returned.

Corrosion Protection

Periodically wash and wax the enclosure using automotive type products. Do not spray the unit with a hose or power washer. Use warm, soapy water and a soft cloth. Frequent washing is recommended in salt water/coastal areas. Spray engine linkages with a light oil such as WD-40®.

Remove From, and Return To Service Procedure

Remove From Service

If the generator cannot be exercised every 7 days and will be out of service longer than 90 days, prepare the generator for storage:

1. Start the engine and let it warm up.
2. Close the fuel shutoff valve in the fuel supply line and allow the unit to shut down.
3. Once the unit has shut down, set the generator main circuit breaker (Generator Disconnect) to OFF (OPEN).
4. Turn off the utility power to the transfer switch.
5. Remove the 7.5 Amp fuse from the generator's control panel.
6. Disconnect the battery cables. Remove negative cable first.
7. Remove battery charger AC input T1/Neutral cable (has white sleeve) at controller.
8. While the engine is still warm, drain the oil completely, and then refill the crankcase with oil.
9. Attach a tag to the engine indicating the viscosity and classification of the new oil in the crankcase.
10. Remove the spark plug(s) and spray a fogging agent into the spark plug(s) threaded openings. Reinstall and tighten the spark plug(s).

11. Remove the battery and store it in a cool, dry room.
12. Clean and wipe down the entire generator.

Return to Service

To return the unit to service after storage:

1. Verify utility power is OFF.
2. Check the tag on the engine for oil viscosity and classification. If necessary, drain and refill with proper oil.
3. Check the state of the battery. Fill all cells of unsealed batteries to the proper level with distilled water. **DO NOT** use tap water. Recharge the battery to 100% state of charge. If defective, replace the battery.
4. Clean and wipe down the entire generator.
5. Make sure the 7.5 Amp fuse is removed from the generator Control Panel.
6. Reconnect the battery. Observe battery polarity. Damage may occur if the battery is connected incorrectly. Install positive cable first.
7. Reconnect the battery charger AC input T1/Neutral cable (has white sleeve) at controller.
8. Open the fuel shutoff valve.
9. Insert the 7.5 Amp fuse into the generator control panel.
10. Start the unit by pressing the MANUAL button. Allow the unit to warm up for a few minutes.
11. Stop the unit by pressing the control panel OFF button.
12. Turn on the utility power to the transfer switch.
13. Set the control panel to AUTO.

The generator is ready for service.

NOTE: When a battery is dead or has been disconnected, the exercise timer and current date and time must be reset.

Section 5: Troubleshooting

System Diagnosis

Problem	Cause	Correction
Engine will not crank.	<ol style="list-style-type: none"> 1. Fuse blown. 2. Loose, corroded or defective battery cables. 3. Defective starter contact. 4. Defective starter motor. 5. Dead battery. 6. Auxiliary shutdown switch is OPEN (O). 	<ol style="list-style-type: none"> 1. Correct short circuit condition by replacing 7.5 Amp fuse in generator control panel. 2. Tighten, clean or replace as necessary.* 3. *See #2. 4. *See #2. 5. Charge or replace battery. 6. Set auxiliary shutdown switch to CLOSED (I) position and clear the alarm.
Engine cranks but will not start.	<ol style="list-style-type: none"> 1. Out of fuel. 2. Defective fuel solenoid (FS). 3. Defective spark plug(s). 4. Valve clearance out of adjustment. 5. In cold weather condition. 	<ol style="list-style-type: none"> 1. Replenish fuel / Turn on fuel valve. 2. * 3. Clean, re-gap or replace plug(s). 4. Reset valve clearance. 5. Install recommended cold weather kit.
Engine starts hard and runs rough.	<ol style="list-style-type: none"> 1. Air cleaner plugged or damaged. 2. Defective spark plug(s). 3. Fuel pressure incorrect. 4. Fuel selector in wrong position. 	<ol style="list-style-type: none"> 1. Check / replace air cleaner. 2. Clean, re-gap or replace plug(s). 3. Confirm fuel pressure to regulator is 10–12 in. water column (19-22 mm mercury) for LP, and 5–7 in. water column (9-13 mm mercury) for natural gas. 4. Turn fuel conversion valve to correct position.
Generator is set to OFF, but the engine continues to run.	<ol style="list-style-type: none"> 1. Controller wired incorrectly 2. Defective control board. 	<ol style="list-style-type: none"> 1. Repair wiring.* 2. Replace control panel*
No AC output from generator.	<ol style="list-style-type: none"> 1. Main line circuit breaker is in the OFF (or OPEN) position. 2. Generator internal failure. 	<ol style="list-style-type: none"> 1. Reset circuit breaker to ON (or CLOSED). 2. *
No transfer to standby after utility source failure.	<ol style="list-style-type: none"> 1. Main line circuit breaker is in the OFF (or OPEN) position. 2. Defective transfer switch coil. 3. Defective transfer relay. 4. Transfer relay circuit open. 5. Defective control logic board. 	<ol style="list-style-type: none"> 1. Reset circuit breaker to ON (or CLOSED). 2. * 3. * 4. * 5. *
Unit consumes large amounts of oil.	<ol style="list-style-type: none"> 1. Engine overfilled with oil. 2. Engine breather defective. 3. Improper type or viscosity of oil. 4. Damaged gasket, seal or hose. 	<ol style="list-style-type: none"> 1. Adjust oil to proper level. 2. * 3. See Engine Oil Requirements. 4. Check for oil leaks.
* Contact an IASD for assistance.		

This page intentionally left blank.

Section 6: Quick Reference Guide

System Diagnosis

To clear an active alarm, press the OFF button twice and then press AUTO. If the alarm reoccurs, contact an Independent Authorized Service Dealer (IASD).

Table 6-1. System Diagnosis

Active Alarm	Problem	Things to Check	Solution
NONE	Unit running in AUTO but no power in house.	Check MLCB.	Check MLCB. If it is in the ON position, contact an IASD.
HIGH TEMPERATURE	Unit shuts down during operation. Auxiliary Shutdown Switch in OPEN (O) position.	Check the Controller for alarms. Check Auxiliary Shutdown Switch position.	Check ventilation around the generator, intake, exhaust and rear of generator. If no obstructions exist, contact an IASD. Set Auxiliary Shutdown Switch to CLOSED (I) position.
HIGH TEMPERATURE	Unit will not start.	Check Auxiliary Shutdown switch position.	Set auxiliary shutdown switch to CLOSED (I) position.
RPM SENSE LOSS	Unit was running and shuts down, attempts to restart.	Check the Controller for alarms.	Clear alarm and remove household loads from the generator. Put back in AUTO and restart. If generator does not start, contact an IASD.
NOT ACTIVATED	Unit will not start in AUTO with utility loss.	Observe if all six Alarm and Warning LEDs are blinking simultaneously.	Refer to "Generator Activation" in the Installation Manual.
LOW OIL PRESSURE	Unit will not start in AUTO with utility loss.	Check the Controller for alarms.	Check oil level / add oil per Owners Manual. If oil level is correct, contact an IASD.
OVERCRANK	Unit will not start in AUTO with utility loss.	Check the Controller for alarms.	Check fuel line shutoff valve is in the ON position. Clear alarm. Attempt to start the unit in MANUAL. If it does not start or starts and runs rough, contact an IASD.
NO LEDs LIT	Unit will not start in AUTO with utility loss.	Check the Controller for alarms.	Check ATO 7.5 Amp ATO® fuse. Replace with same type fuse if bad. Contact IASD if fuse is good.
SPEED ALARM	Unit will not start in AUTO with utility loss.	Check the Controller for alarms.	Contact IASD.
WIRING ERROR	Unit will not start in AUTO with utility loss.	Check the Controller for alarms.	Contact IASD.
BATTERY PROBLEM	Yellow LED steadily illuminated	Check the Controller for additional information.	Contact IASD.
CHARGER PROBLEM	Yellow LED flashes	Check the Controller for additional information.	Contact IASD.
BREAK-IN MAINTENANCE DUE	Control panel indicates break-in maintenance due.LED flashes.	None	Perform break-in maintenance. Clear Maintenance Due light.

Table 6-1. System Diagnosis (Continued)

Active Alarm	Problem	Things to Check	Solution
1 YEAR / 100 HOUR MAINTENANCE DUE	Control panel indicates scheduled maintenance due.LED illuminates.	None	Perform scheduled maintenance. Clear Maintenance Due light.
NONE	Utility present. Generator running. Active mode LED (AUTO/MANUAL/OFF) is flashing.	Check utility sense lines / utility disconnect.	Contact IASD. Close utility disconnect.

This page intentionally left blank.

This page intentionally left blank.

Part No. 1000021790 Rev. A 02/21/18
©2018 Generac Power Systems, Inc.
All rights reserved
Specifications are subject to change without notice.
No reproduction allowed in any form without prior written
consent from Generac Power Systems, Inc.

GENERAC®

Generac Power Systems, Inc.
S45 W29290 Hwy. 59
Waukesha, WI 53189
1-888-GENERAC (1-888-436-3722)
www.generac.com