

Residential generator set RS Air-Cooled Series RS20A/AC & RS14AF Model GSBB



Cummins Onan



Performance you rely on.™

Features and benefits

- Very quiet operation
- Internet remote monitoring and email notification
- Automatic load management - The intelligent generator control automatically manages non-essential household loads for maximum utilization of generator power
- Cummins Onan designed alternator and electronic control
- Powerful motor starting - starts and runs a 5 ton A/C¹ under full pre-load
- GFCI "Ready"
- Self-diagnostic capability
- Service and maintenance information displayed on in home display
- Easy installation with innovative molded polymer installation base - no need for a concrete pad

- Electronic governor for precise frequency control
- Flexible 12 inch fuel line provided with genset
- Generator designed and manufactured in the USA
- U.S. EPA and CARB Emissions Certified
- UL 2200 Listed and CSA Certified generator and transfer switch for your protection
- Quality power output, less than 5% THD
- 5 year, 2000 hour limited warranty

Weight, size and sound level

Weight: 540 lb (245 kg)

Size: Length 53 in (1346 mm), width 43 in (1092 mm), height 34.7 in (880 mm)

Sound: 62 dB(A) at 23 ft (7 m) at normal load²

Series	Order model	Part number	Fuel	Voltage	Frequency	Rated amps ³	Circuit breaker	Cold weather equipped	Listing
RS20A	20GSBB-6713A	A029T463	Natural gas	120/240	60 Hz	144/72	100 A, 2 pole	No	UL
RS20A	20GSBB-6713A	A029T463	LP vapor	120/240	60 Hz	162.5/81.25	100 A, 2 pole	No	UL
RS20A	20GSBB-6714A	A029U509	Natural gas	120/240	60 Hz	144/72	100A, 2 pole	Yes	UL
RS20A	20GSBB-6714A	A029U509	LP vapor	120/240	60 Hz	162.5/81.25	100A, 2 pole	Yes	UL
RS20AC	20GSBB-6717A	A030S533	Natural gas	120/240	60 Hz	140/70	100A, 2 pole	Yes	CSA
RS20AC	20GSBB-6717A	A030S533	LP vapor	120/240	60 Hz	154/77	100A, 2 pole	Yes	CSA
RS14AF	14GSBB-6716A	A029U513	Natural gas	115/230	50 Hz	113/56.5	60A, 2 pole	No	None
RS14AF	14GSBB-6716A	A029U513	LP vapor	115/230	50 Hz	113/56.5	60A, 2 pole	No	None

¹ Air-conditioners vary by type, efficiency, operational conditions, etc. Consult with a qualified HVAC specialist or Cummins Onan distributor/dealer for proper sizing.

² Normal load is defined as typical household consumption of 3kW.

³ Derating guidelines: Maximum wattage or maximum current are subject to and limited by such factors as fuel Btu content, ambient temperature, altitude, engine power and condition, etc. Full rated power available at 60 °F (15.5°C) and sea level. Derate 3.5% for each 1000 ft (304.8 m) above sea level and 3% for each 10 °F (5.5 °C) increase in ambient temperature above 60 °F (15.5 °C). Maximum wattage or maximum current are based upon minimum service voltage in accordance with UL 2200 (Stationary Engine Generator Assemblies) or CSA C22.2 No. 100-04 (Motors and Generators).

Engine

Model: 993 cc, air-cooled v-twin OHV

Compression ratio: 8.3:1

Displacement: 60.6 cu in (993 cc)

Oil sump capacity: 2.43 qt (2.3 L) with filter

Operating speed: 3600 rpm

Fuel supply pressure: NG 5-11 in H₂O, LP 7-11 in H₂O

- Integrated oil drain valve and extension tube included
- Simple fuel conversion between natural gas and LP
- 20 A battery charger
- Highly reliable solenoid shift starter
- Transistorized magneto ignition
- Automotive-style lubrication system
- Oil cooler
- Spin-on oil filter
- Electronic governor
- Large-capacity air cleaner
- CARB Certified, U.S. EPA Certified

Weather protective sound enclosure

- Thick 11 gauge aluminum enclosure with resilient architectural grade powder coat paint
- Durable polypropylene base eliminates need for concrete pad
- UL Listed, impact resistant, fully colored, automotive grade polypropylene cover with UV stabilizer
- All maintenance points are accessible without the use of tools
- "Under the hood" oil dipstick check and fill
- Electrical stub-up and side knockouts provided on genset for installation flexibility
- Patented, innovative, compact and neighborhood friendly design blends into any residential setting
- Lift-off enclosure for close proximity installations
- No exposed fasteners
- Key lockable
- High intake and exhaust to reduce rain ingestion and snow blockage
- GFCI "Ready" mounting location provided on genset enclosure
- Externally mounted circuit breaker with weatherproof cover

Exhaust muffler

- Large automotive grade corrosion resistant muffler design
- Low noise

Load management

- Automatically turns on/off loads to prevent generator overload
- Easy to set up from in-home display
- Easily connected at the generator

Note: Additional installation and relays are required.

Control system

- Cummins Proprietary electronic control with self diagnostics and generator set protection and safety features included
- Automatically starts and stops generator upon identification of a power outage
- Microprocessor control manages generator set operation, fault detection and service diagnostics
- Illuminated run/off/auto switch
- Convenient access to all connection points
- Fully automatic operation

Internet/email capability

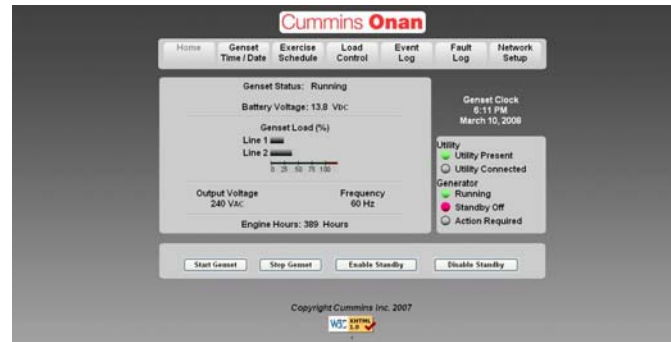

- Sends you or your service technician an email if service or maintenance is required.
- View generator status from the internet.
Note: Network Specialist required for set-up
- Installation and set-up is required. See Installation Manual for additional details.

In-home display



- Wired in-home LCD display is offered standard on every set.
- Surface mountable at genset (standard) or remotely (installation required).
- Power continually supplied to the display; no need for replaceable batteries.
- Genset can be started/stopped from the display.
- Easily set/adjust genset exercise for day and time, with capability to choose weekly, bi-weekly or monthly.
- Displays maintenance and service reminders.
- Percent load is displayed allowing user to manage load.
- Displays last 30 faults for troubleshooting.
- Displays last 30 events (i.e., day and time of power outage, exercise, etc.).
- Adjust and configure RSS service entrance ATS models.

Cummins®, Onan®, the "C" logo and Performance you rely on.™ are servicemarks, trademarks and/or registered trademarks of Cummins Inc. Other company, product or service names may be trademarks or service marks of others. Specifications are subject to change without notice.

©2010 Cummins Power Generation. All Rights Reserved.

A-1555b (8/10)

Average fuel consumption:*

Fuel consumption-natural gas

Load:	1/4	1/2	3/4	Full
ft ³ /hr	90	135	175	240
m ³ /hr	2.5	3.8	5.0	6.8
Kg/hr	2.5	3.4	4.8	6.6
Btu/hr	90000	135000	175000	240000
Nominal fuel rating - 37 MJ/m ³ (1000 Btu/ft ³).				

Fuel consumption-LP vapor

Load:	1/4	1/2	3/4	Full	Conversion factor
ft ³ /hr	35	53	75	110	8.58 ft ³ = 1 lb
m ³ /hr	1.0	1.5	2.1	3.1	0.535 m ³ = 1 kg
Gal/h:	1.0	1.5	2.1	3.0	36.39 ft ³ = 1 Gal
L/hr	3.6	5.5	7.8	11.4	
Kg/hr	2.5	3.8	5.7	7.9	
Btu/hr	87500	132500	187500	275000	
Nominal fuel rating - 93 MJ/m ³ (2500 Btu/ft ³).					

* Approximately 15% lower fuel consumption at 50 Hz

Alternator details

Design: Cummins Onan 2-pole, self-excited revolving field. Permanently aligned to engine by a tapered shaft.
 AC waveform total harmonic distortion: Less than 5% THD (total harmonic distortion).
 Insulation system and temperature rise: Class H insulation per NEMA MG-1-1-66.
 Cooling: Direct-drive, centrifugal blower.
 Rotor: Laminated electrical steel assembly skewed for improved voltage waveform, heavy insulated copper wire windings.
 Bearing: Double-sealed pre-lubricated ball bearing.
 DC brushes: Electrographitic, long life, easily serviced.

Generator set performance

Voltage regulation: ±1.5% no load to full load.
 Frequency regulation: Isochronous, 0% no load to full load.
 Motor starting kVA (30% voltage dip): 40
 Operating temperature:
 122 °F (50 °C) to 20 °F (-7 °C): Standard Model
 122 °F (50 °C) to 0 °F (-18 °C): Cold Weather Equipped Model
 Additional accessories are available to allow for operation down to -20 °F (-29 °C) or high humidity. See Accessories section for details.

Easy Service & Installation

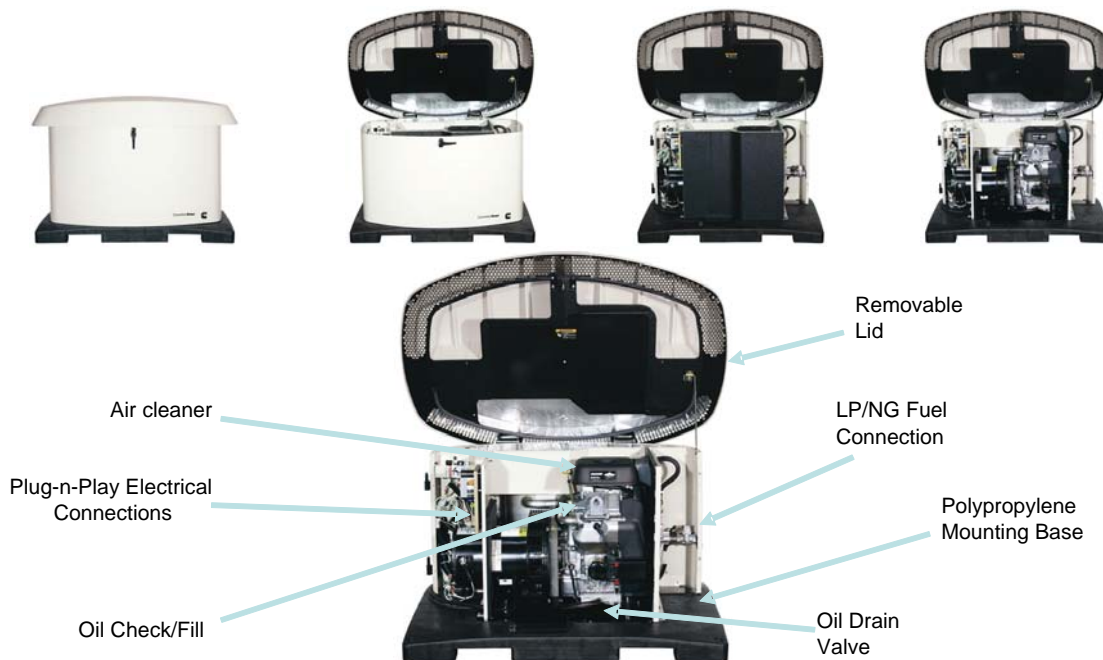

Automatic transfer panel configurations

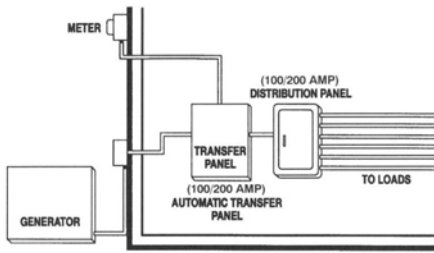

Service entrance installation (USA only) (100/200 A)

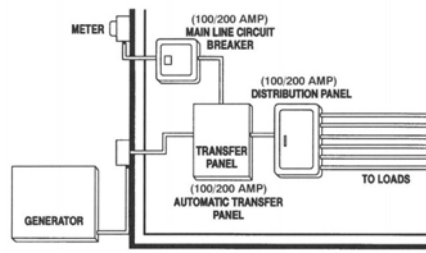

Service entrance installation (USA and Canada) (100/200 A)

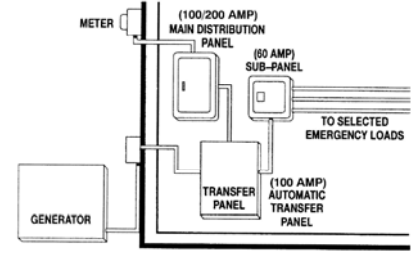

Dedicated emergency standby service system (100/200 A) (USA and Canada)

Basic dimensions

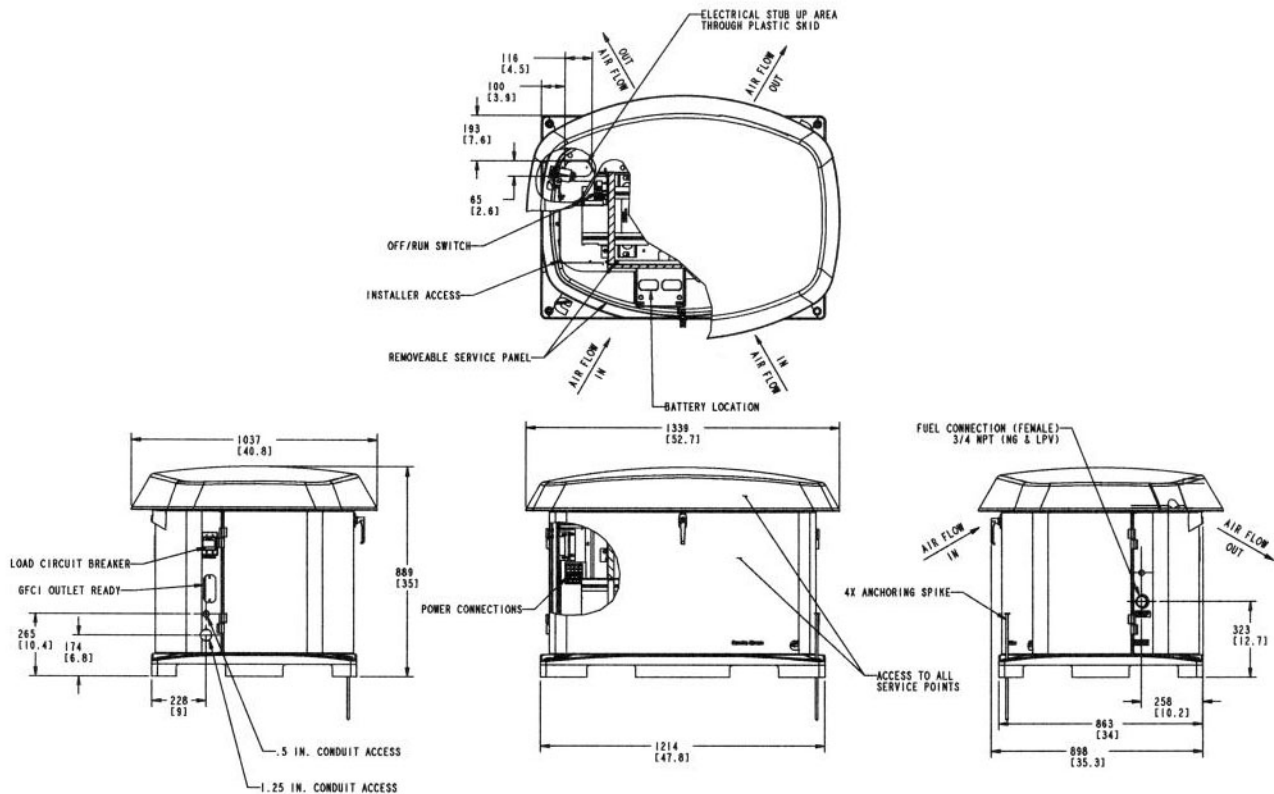

Note: This outline drawing (A029Z911) is provided for general reference only and is not intended for use in design or installation. For more information, see Operators and Installation manuals or contact your distributor or dealer for assistance.

UL 1008 Listed: RSS100-6868, RSS200-6869 (0500-4824)

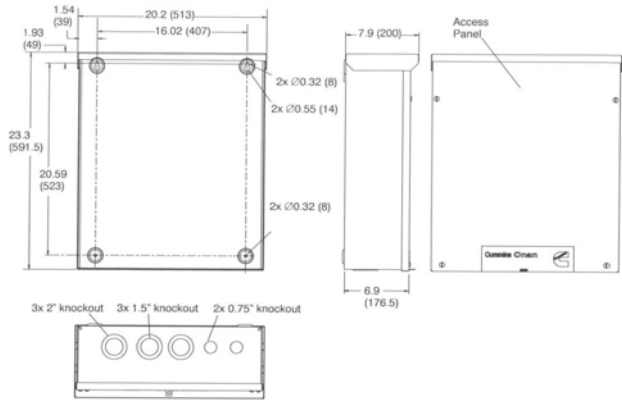

CSA/UL RSS100-6634 (0500-4502)

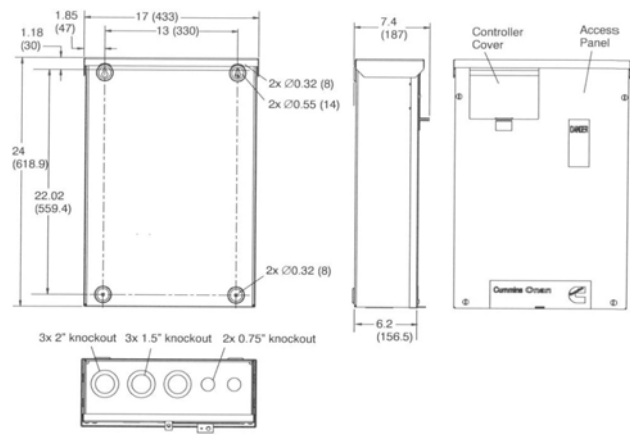

CSA/UL RSS200-6635 (0500-4503)

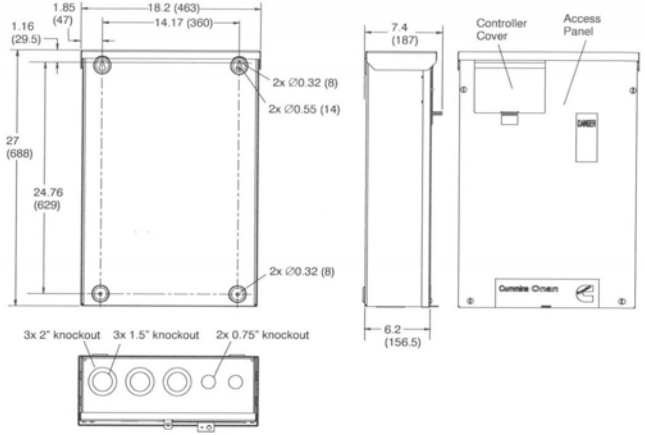

Options and accessories

- Installation wheel kit (P/N 0541-1624)
- Additional in-home display (P/N 0300-6576)

Climate Accessories:

- Breather heater kit (P/N A030W752)
- Battery heater kit (P/N 0333-0770)
- Alternator dryer kit (P/N A029J885)

Climate	Breather Heater	Battery Heater*	Alternator Dryer
Below 0 °F	X		
Below -10 °F	X	X	
High Humidity			X

* A battery with higher CCA can be used in place of this accessory.

Battery requirement

- 12 V, group 26R, 530 CCA Maintenance Free

Warranty policy

Cummins Onan RS20A, RS20AC, and 14AF generators come standard with a 5 year/2000 hour limited warranty. Extended warranty options available. See warranty statement for additional details.



⚠ IMPORTANT

Standby rating based on: Applicable for supplying emergency power for the duration of normal power interruption. No sustained overload capability is available for this rating. (Equivalent to fuel stop power in accordance with ISO3046, AS2789, DIN6271 and BS5514.) nominally rated. See T030.

⚠ WARNING:

Back feed to a utility system can cause electrocution and/or property damage. Do not connect to any building electrical except through an approved device or after building main breaker is open.

Transfer switch (also sold separately)

- 100 and 200 amp automatic transfer switch NEMA 3R.
- Fully automatic operation with Cummins Onan RSS model automatic transfer switch.
- Reduces installation time with indoor/outdoor flexibility and whole house install.
- Two amp trickle battery charger included
- UL 1008 Listed Service Entrance Rated: RSS100-6868, RSS200-6869
- CSA Approved and UL 1008 Listed: RSS100-6634, RSS200-6635

Plug-n-play installation harnesses

- Generator to ATS harness:
 - 1 ft. length (p/n A029U298)
 - 50 ft. length (p/n A029U302)
 - 100 ft. length (p/n A029U303)
 - 200 ft. length (p/n A029U304)
- Remote display harness:
 - 1 ft. length (p/n A029U306)
 - 50 ft. length (p/n A029U308)
 - 100 ft. length (p/n A029U310)
 - 200 ft. length (p/n A029U311)

After sale support

Largest distributor/dealer support network
 Cummins Onan generator sets are supported by the largest and best trained worldwide certified distributor/dealer network in the industry. This network of knowledgeable distributor/dealers will help you select and install the right generator set and accessories to meet the requirements of your specific application. This same network offers a complete selection of commonly used generator set maintenance parts, accessories and products plus manuals and specification sheets. Plus, they can answer your questions regarding proper operation, maintenance schedules and more.

Manuals: Operation and installation manuals ship with the generator set. To obtain additional copies or other manuals for this model, see your distributor/dealer and request the following manual numbers: Operator (A029V089), Installation (A029V088) Parts (A029Y325), Service (A030A239).

To easily locate the nearest certified distributor/dealer for Cummins Onan generators in your area, or for more information, contact us at 1-800-344-0039 or visit www.cumminsonan.com.

Contact your distributor/dealer for more information.

Cummins Onan

Cummins Power Generation
 1400 73rd Ave. NE
 Minneapolis, MN 55432 USA
 Toll-free 1 800 344-0039
 Fax 1 763 574 5298
 Email www.cumminsonan.com/contact
www.cumminsonan.com



Cummins®, Onan®, the "C" logo and Performance you rely on.™ are servicemarks, trademarks and/or registered trademarks of Cummins Inc. Other company, product or service names may be trademarks or service marks of others. Specifications are subject to change without notice.

©2010 Cummins Power Generation. All Rights Reserved.

A-1555b (8/10)