

# **Robin** **Generator**

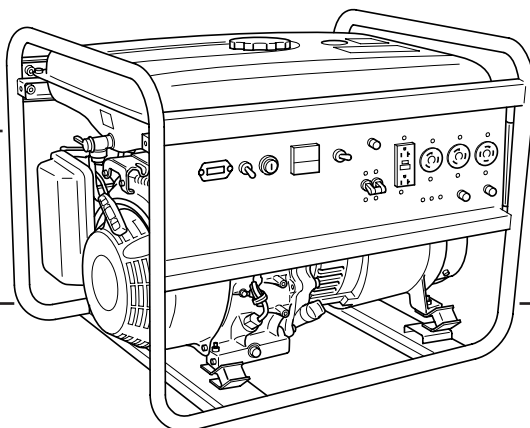

MODEL  
**RGV7500**

**INSTRUCTIONS for USE**



**3ZZ9020169**



## WARNING:



The engine exhaust from this product contains chemicals known to the State of California to cause cancer, birth defects or other reproductive harm.

## NOTICE

FEDERAL EMISSION COMPONENT DEFECT WARRANTY and CALIFORNIA EMISSION CONTROL WARRANTY are applicable to only those engines/generators complied with EPA (Environmental Protection Agency) and CARB (California Air Resources Board) emission regulations in the U.S.A.

## NOTICE

To the engines/generators exported to and used in the countries other than the U.S.A., warranty service shall be performed by the distributor in each country in accordance with the standard Robin engine/generator warranty policy as applicable.

## AIR INDEX

To show compliance with California emission regulations, a hangtag has been provided displaying the Air Index level and durability period of this engine.

The Air Index level defines how clean an engine's exhaust is over a period of time. A bar graph scaled from "0" (most clean) to "10" (least clean) is used to show an engine's Air Index level. A lower Air Index level represents cleaner exhaust from an engine.

The period of time (in hours) that the Air Index level is measured is known as the durability period. Depending on the size of the engine, a selection of time periods can be used to measure the Air Index level (see below).

<u>Descriptive Term</u>	<u>Applicable to Emissions Durability Period</u>
Moderate	- 50 hours (engine from 0 to 80 cc)
	- 125 hours (engine greater than 80 cc)
Intermediate	- 125 hours (engine from 0 to 80 cc)
	- 250 hours (engine greater than 80 cc)
Extended	- 300 hours (engine from 0 to 80 cc)
	- 500 hours (engine greater than 80 cc)

**Notice :** This hangtag must remain on this engine or piece of equipment, and only be removed by the ultimate purchaser before operation.

# FEDERAL EMISSIONS COMPONENT DEFECT WARRANTY

**EMISSIONS COMPONENT DEFECT WARRANTY COVERAGE** - This emission warranty is applicable in all States, except the State of California

Fuji Heavy Industries Ltd. and Robin America Inc., Wood Dale Illinois, (herein "ROBIN AMERICA") warrant(s) to the initial retail purchaser and each subsequent owner, that this Nonroad engine (herein "engine") has been designed, built, and equipped to conform at the time of initial sale to all applicable regulations of the U.S. Environmental Protection Agency (EPA), and that the engine is free of defects in materials and workmanship which would cause this engine to fail to conform with EPA regulations during its warranty period.

For the components listed under PARTS COVERED, the service dealer authorized by ROBIN AMERICA will, at no cost to you, make the necessary diagnosis, repair, or replacement necessary to ensure that the engine complies with applicable U.S. EPA regulations.

## EMISSION COMPONENT DEFECT WARRANTY PERIOD

The warranty period for this engine begins on the date of sale to the initial purchaser and continues for a period of 2 years.

## PARTS COVERED

Listed below are the parts covered by the Emission Components Defect Warranty. Some of the parts listed below may require scheduled maintenance and are warranted up to the first scheduled replacement point for that part.

- |   |  |
|---|--|
| (1) Fuel Metering System  | (3) Ignition System                                  |
| (i) Carburetor and internal parts (and/or pressure regulator or fuel injection system). | (i) Spark plugs.                                     |
| (ii) Air/fuel ratio feedback and control system, if applicable.                         | (ii) Magneto or electronic ignition system.          |
| (iii) Cold start enrichment system, if applicable.                                      | (iii) Spark advance/retard system, if applicable.    |
| (iv) Regulator assy (gaseous fuel, if applicable)                                       | (4) Exhaust manifold, if applicable                  |
| (2) Air Induction System  | (5) Miscellaneous Items Used in Above Systems        |
| (i) Intake manifold, if applicable  | (i) Electronic controls, if applicable               |
| (ii) Air filter.  | (ii) Hoses, belts, connectors, and assemblies.       |
|   | (iii) Filter lock assy (gaseous fuel, if applicable) |

## OBTAINING WARRANTY SERVICE

To obtain warranty service, take your engine to the nearest authorized Robin America service dealer. Bring your sales receipts indicating date of purchase for this engine. The service dealer authorized by ROBIN AMERICA will perform the necessary repairs or adjustments within a reasonable amount of time and furnish you with a copy of the repair order. All parts and accessories replaced under this warranty become the property of ROBIN AMERICA.

## WHAT IS NOT COVERED

\*Conditions resulting from tampering, misuse, improper adjustment (unless they were made by the service dealer authorized by ROBIN AMERICA during a warranty repair), alteration, accident, failure to use the recommended fuel and oil, or not performing required maintenance services.

- \*The replacement parts used for required maintenance services.
- \*Consequential damages such as loss of time, inconvenience, loss of use of the engine or equipment, etc.
- \*Diagnosis and inspection charges that do not result in warranty-eligible service being performed.
- \*Any non-authorized replacement part, or malfunction of authorized parts due to use of non-authorized parts.

## **OWNER'S WARRANTY RESPONSIBILITIES**

As the engine owner, you are responsible for the performance of the required maintenance listed in your owner's manual. ROBIN AMERICA recommends that you retain all receipts covering maintenance on your engine, but ROBIN AMERICA cannot deny warranty solely for the lack of receipts or for your failure to ensure the performance of all scheduled maintenance.

As the engine owner, you should however be aware that ROBIN AMERICA may deny warranty coverage if your engine or a part has failed due to abuse, neglect, improper maintenance or unapproved modifications.

You are responsible for presenting your engine to the nearest service dealer authorized by ROBIN AMERICA when a problem exists.

If you have any questions regarding your warranty rights and responsibilities, you should contact the Robin America customer service department at 1-630-350-8200 for the information.

## **THINGS YOU SHOULD KNOW ABOUT THE EMISSION CONTROL SYSTEM WARRANTY MAINTENANCE AND REPAIRS**

You are responsible for the proper maintenance of the engine. You should keep all receipts and maintenance records covering the performance of regular maintenance in the event questions arise. These receipts and maintenance records should be transferred to each subsequent owner of the engine. ROBIN AMERICA reserves the right to deny warranty coverage if the engine has not been properly maintained. Warranty claims will not be denied, however, solely because of the lack of required maintenance or failure to keep maintenance records.

MAINTENANCE, REPLACEMENT OR REPAIR OF EMISSION CONTROL DEVICES AND SYSTEMS MAY BE PERFORMED BY ANY REPAIR ESTABLISHMENT OR INDIVIDUAL ; HOWEVER, WARRANTY REPAIRS MUST BE PERFORMED BY A SERVICE DEALER AUTHORIZED BY ROBIN AMERICA. THE USE OF PARTS THAT ARE NOT EQUIVALENT IN PERFORMANCE AND DURABILITY TO AUTHORIZED PARTS MAY IMPAIR THE EFFECTIVENESS OF THE EMISSION CONTROL SYSTEM AND MAY HAVE A BEARING ON THE OUTCOME OF A WARRANTY CLAIM.

If other than the parts authorized by ROBIN AMERICA are used for maintenance replacements or for the repair of components affecting emission control, you should assure yourself that such parts are warranted by their manufacturer to be equivalent to the parts authorized by ROBIN AMERICA in their performance and durability.

## **HOW TO MAKE A CLAIM**

All repair qualifying under this limited warranty must be performed by a service dealer authorized by ROBIN AMERICA. In the event that any emission-related part is found to be defective during the warranty period, you shall notify Robin America customer service department at 1-630-350-8200 and you will be advised of the appropriate warranty service dealer or service providers where the warranty repair can be performed.

# **CALIFORNIA EMISSION CONTROL WARRANTY STATEMENT YOUR WARRANTY RIGHTS AND OBLIGATIONS**

The California Air Resources Board and Fuji Heavy Industries Ltd. (herein "FUJI") are pleased to explain the emission control system warranty on your 2005 and later Small Off-Road engine (herein "engine"). In California, the engine must be designed, built and equipped to meet the State's stringent anti-smog standards. FUJI must warrant the emission control system on your engine for the periods of time described below, provided there has been no abuse, neglect or improper maintenance of your engine. Your emission control system may include parts such as the carburetor or fuel-injection system, and the ignition system. Also included may be hoses, belts, connectors and other emission-related assemblies. Where a warrantable condition exists, FUJI will repair your engine at no cost to you including diagnosis, parts and labor.

## **MANUFACTURER'S WARRANTY COVERAGE :**

The 2005 and later engines are warranted for two (2) years. If any emission related part on your engine is defective, the part will be repaired or replaced by FUJI.

## **OWNER'S WARRANTY RESPONSIBILITIES :**

- As the engine owner, you are responsible for the performance of the required maintenance listed in your Owner's Manual. FUJI recommends that you retain all receipts covering maintenance on your engine, but FUJI cannot deny warranty solely for the lack of receipts or for your failure to ensure the performance of all scheduled maintenance.
- As the engine owner, you should ,however, be aware that FUJI may deny you warranty coverage if your engine or a part has failed due to abuse, neglect, improper maintenance or unapproved modifications.
- You are responsible for presenting your engine to a service dealer or warranty station authorized by ROBIN AMERICA Inc. 940 Lively Blvd., Wood Dale, IL 60191 (herein ROBIN AMERICA) as soon as a problem exists. The warranty repairs should be completed in a reasonable amount of time, not to exceed 30 days.

If you have any questions regarding your warranty rights and responsibilities, you should contact the Robin America Inc. Customer Service Department at 1-630-350-8200

# **LIMITED WARRANTY**

## **on Emission Control Systems**

### **– California Only –**

FUJI warrants to the owner of the 2005 and later engine that the engine (1) has been designed, built and equipped so as to conform at the time of manufacture with the applicable regulations of the California Air Resources Board, and (2) is free from defects in materials and workmanship that could cause it to fail to conform with those regulations as may be applicable in the terms and conditions stated below.

#### **A. COMMENCEMENT DATE**

The warranty period begins on the date the engine is delivered to a first retail purchaser.

#### **B. LENGTH OF COVERAGE**

FUJI warrants to a first retail purchaser and each subsequent purchaser that the engine is free from defects in materials and workmanship that cause the failure of a warranted emission-related part for a period of two (2) years after the date of delivery to the first retail purchaser.

#### **C. WHAT IS COVERED :**

##### **1. REPAIR OR REPLACEMENT PARTS**

Repairs and replacement of any warranted part will be performed at no charge to you by an authorized service dealer or a warranty station. You may contact the Robin America Inc. Customer Service Department at 1-630-350-8200 to obtain the name of the nearest appropriate location where your warranty repairs are performed.

##### **2. WARRANTY PERIOD**

This warranty continues for a period of two (2) years and applies only to the repair, replacement or adjustment of the component parts that are not scheduled for replacement as required maintenance. Further, component parts which are scheduled only for regular inspection to the effect of "repair or replace as necessary" are warranted for the warranty period. Any warranted part which is scheduled for replacement as required maintenance is warranted for the period of time up to the first scheduled replacement point for that part.

##### **3. DIAGNOSIS**

You will not be charged for diagnostic labor that leads to the determination that a warranted part is defective, if the diagnostic work is performed at an authorized service dealer or warranty station.

##### **4. DAMAGES**

If a warranted part failed causing damage to other engine components, consult an warranty station.

#### **D. WHAT IS NOT COVERED**

1. This limited warranty does not cover any part which malfunctions, fails or is damaged due to failure to follow the maintenance and operating instructions set forth in the 2005 and later Owner's Manual including:

- (1) improper maintenance of any warranted parts
- (2) improper installation, adjustment or repair of the engine or of any warranted part unless performed by an authorized service dealer
- (3) failure to follow recommendations on fuel use contained in the 2005 and later Owner's Manual

- (4) repairs performed outside of the authorized warranty service dealers
  - (5) use of parts which are not authorized by FUJI.
2. Add-on or modified parts  
This warranty does not cover any part that malfunctions, fails or is damaged due to alterations by changing, adding to or removing parts from the engine.
3. Expenses incurred by processing warranty claims  
FUJI, any authorized service dealer and warranty station shall not be liable for any loss of use of the engine, for any alternative usage, for any damage to goods, loss of time or inconvenience.

#### E. HOW TO FILE A CLAIM

All repairs qualifying under this Limited Warranty must be performed by a dealer who sold you the engine or warranty station authorized by ROBIN AMERICA. In the event that any emission-related part is found to be defective during the warranty period, you must notify the Robin America Inc. Customer Service Department at 1-630-350-8200 and you will be advised of the appropriate warranty service facilities where the warranty repair is to be performed.

#### F. WHERE TO OBTAIN WARRANTY SERVICE

It is recommended that warranty service be performed by the authorized dealer who sold you the engine, although warranty service will be performed by any authorized service dealers or warranty stations anywhere in the United States. When warranty repair is needed, the engine must be brought to an authorized service dealer or warranty station's place of business during normal business hours. In all cases, a reasonable time, not to exceed 30 days, must be allowed for the warranty repair to be completed after the engine is received by the authorized service dealer or warranty station.

#### G. MAINTENANCE, REPLACEMENT AND REPAIR OF EMISSION-RELATED PARTS

Only warranted engine replacement parts approved by FUJI should be used in the performance of any warranty maintenance or repairs on emission-related parts. If other than authorized parts are used for maintenance, replacement or repair of components affecting emission control, you should assure yourself that such parts are warranted by their manufacturer to be equivalent to authorized parts in performance and durability. FUJI, however, assumes no liability under this warranty with respect to parts other than authorized parts. The use of non-authorized replacement parts does not invalidate the warranty on other components unless the non-authorized parts cause damage to warranted parts.

#### H. PARTS COVERED UNDER THE CALIFORNIA EMISSIONS WARRANTY

##### (1) Fuel Metering System

- (i) Carburetor and internal parts (and/or pressure regulator or fuel injection system).
- (ii) Air/fuel ratio feedback and control system, if applicable.
- (iii) Cold start enrichment system, if applicable.
- (iv) Regulator assy (gaseous fuel, if applicable)

##### (2) Air Induction System

- (i) Intake manifold, if applicable
- (ii) Air filter.

##### (3) Ignition System

- (i) Spark plugs.
- (ii) Magneto or electronic ignition system.
- (iii) Spark advance/retard system, if applicable.

- (4) Exhaust manifold, if applicable
- (5) Miscellaneous Items Used in Above Systems
  - (i) Electronic controls, if applicable
  - (ii) Hoses, belts, connectors, and assemblies.
  - (iii) Filter lock assy (gaseous fuel, if applicable)

## I. MAINTENANCE STATEMENTS

It is your responsibility to have all scheduled inspection and maintenance services performed at the times recommended in the 2005 and later Owner's Manual and to retain proof that inspection and maintenance services are performed at the times when recommended. FUJI will not deny a warranty claim solely because you have no record of maintenance; however, FUJI may deny a warranty claim if your failure to perform required maintenance resulted in the failure of warranted part. The proof which you maintain should be given to each subsequent owner of the engine. You are responsible for performing the scheduled maintenance described below based on the procedures specified in the 2005 and later Owner's Manual. The scheduled maintenance below is based on a normal engine operating schedule.

PROCEDURE	INTERVAL
1) Change engine oil	: Initial 20 hours and every 100 hours afterward
2) Clean air cleaner (element)	: Every 50 hours
3) Replace air cleaner element	: Every 200 hours
4) Clean and adjust spark plug and electrodes	: Every 200 hours

Note: More frequent maintenance may be necessary under dusty, dirty or severe conditions.



# FOREWORD

Thank you for purchasing a Robin generator.

This manual covers operation and maintenance of the Robin generators. All information in this publication is based on the latest production information available at the time of approval for printing.

Pay special attention to statements preceded by the following words:

## **WARNING**

Indicates a strong possibility of severe personal injury, loss of life and equipment damage if instructions are not followed.

## **[CAUTION]**

Indicates a possibility of personal injury or equipment damage if instructions are not followed.

## **NOTE :**

Gives helpful information.

If a problem should arise, or if you have any questions about the generator, consult an authorized dealer or service shop

## **WARNING**





- **The generator is designed to give safe and dependable service if operated according to instructions.**
- **Do not operate the generator before you have read and understood the instructions. Failure to do so could result in death, personal injury or equipment damage.**









# CONTENTS

1. SAFETY PRECAUTIONS . . . . .	1
2. SPECIFICATIONS . . . . .	4
3. COMPONENTS . . . . .	5
4. PRE-OPERATION CHECKS . . . . .	6
5. OPERATING PROCEDURES . . . . .	11
6. WATTAGE INFORMATION . . . . .	22
7. SPARK ARRESTER . . . . .	24
8. MAINTENANCE SCHEDULE . . . . .	25
9. "HOW-TO" MAINTENANCE . . . . .	27
10. PREPARATION FOR STORAGE . . . . .	30
11. TROUBLESHOOTING . . . . .	31
12. WIRING DIAGRAM . . . . .	32
13. OPTIONAL PARTS . . . . .	34

# 1. SAFETY PRECAUTIONS

---

-  Do not operate the generator near gasoline or gaseous fuel because of the potential danger of explosion or fire.  
Do not fill the fuel tank with fuel while the engine is running. Do not smoke or use open flame near the fuel tank. Be careful not to spill fuel during refueling. If fuel is spilt, wipe it off and let dry before starting the engine.
-  Do not place in flammables near the generator.  
Be careful not to place fuel, matches, gunpowder, oily cloths, straw, trash, or any other in flammables near the generator.
-  Do not operate the generator inside a room, cave, tunnel, or other insufficiently ventilated area. Always operate it in a well-ventilated area, otherwise the engine may become overheated, and the poisonous carbon monoxide gas contained in the exhaust gases will endanger human lives. Keep the generator at least 1 meter (3 feet) away from any structure or building during use.  
If the generator must be used indoors, the area must be well-ventilated and extreme caution must be taken regarding the discharge of exhaust gases.
-  Do not enclose the generator nor cover it with a box.  
The generator has a built-in forced air cooling system, and may become overheated if it is enclosed. If generator has been covered to protect it from the weather during non use, be sure to remove it and keep it well away from the area during generator use.
-  Operate the generator on a level surface.  
It is not necessary to prepare a special foundation for the generator. However, the generator will vibrate on an irregular surface, so choose a level place without surface irregularities.  
If the generator is tilted or moved during operation, fuel may spill and / or the generator may tip over, causing a hazardous situation.  
Proper lubrication cannot be expected if the generator is operated on a steep incline or slope. In such a case, piston seizure may occur even if the oil is above the upper level.

- 
-  Pay attention to the wiring or extension cords from the generator to the connected device.  
If the wire is under the generator or in contact with a vibrating part, it may break and possibly cause a fire, generator burnout, or electric shock hazard. Replace damaged or worn cords immediately.
  -  Do not operate in rain, in wet or damp conditions, or with wet hands.  
The operator may suffer severe electric shock if the generator is wet due to rain or snow.
  -  If wet, wipe and dry it well before starting. Do not pour water directly over the generator, nor wash it with water.
  -  Be extremely careful that all necessary electrical grounding procedures are followed during each and every use. Failure to do so can be fatal.
  -  Do not contact the generator to a commercial power line. Connection to a commercial power line may short circuit the generator and ruin it or cause electric shock hazard. Use the transfer switch for connecting to domestic circuit.
  -  No smoking while handling the battery. The battery emits flammable hydrogen gas, which can explode if exposed to electric arcing or open flame. Keep the area well-ventilated and keep open flames/sparks away when handling the battery.
  -  Engine becomes extremely hot during and for some time after operation. Keep combustible materials well away from generator area.  
Be very careful not to touch any parts of the hot engine especially the muffler area or serious burns may result.
  -  Keep children and all bystanders at a safe distance from work areas.

---

 It is absolutely essential that you know the safe and proper use of the power tool or appliance that you intend to use. All operators must read, understand and follow the tool/appliance owners manual. Tool and appliance applications and limitations must be understood. Follow all directions given on labels and warnings. Keep all instruction manuals and literature in a safe place for future reference.

 Use only "LISTED" extension cords. When a tool or appliance is used outdoors, use only extension cords marked "For Outdoor Use". Extension cords, when not in use should be stored in a dry and well ventilated area.

 Always switch off generator's no-fuse breaker and disconnect tools or appliances when not in use, before servicing, adjusting, or installing accessories and attachments.

# 2. SPECIFICATIONS

MODEL		RGV7500		
Alternator	Type	Brush, Self-Exciting, 2-Poles, Single Phase		
	Voltage regulator	A.V.R type		
	Rated voltage	60 Hz	120 V/ 240 V	
	Maximum output	60 Hz	7.3 kW	
	Rated output	60 Hz	6.0 kW	
	Rated power factor		1.0	
	DC output		12V-8.3A	
	Over current protector		No-fuse Breaker	
Engine	Model	EH41D (EH41DS)*		
	Type	Forced air-cooled, 4-cycle, Gasoline Engine		
	Displacement	404 cm <sup>3</sup>		
	Fuel	Automotive unleaded gasoline		
	Fuel tank capacity	7.26 US-gal (27.5 liter)		
	Rated continuous operation (Approx.)	60 Hz	7.0 hours	
	Starting system	Recoil (Electric starter)*		
Dimension	Length	27.2 in. (690 mm) / 33.9 in. (860 mm) *		
	Width	20.9 in. (530 mm)		
	High	20.9 in. (530 mm)		
Dry weight		198.4 lb (90 kg) / 209.4 lb (95 kg) *		
Valve Clearance (Intake & Exhaust)		0.0039±0.0012 in. (0.1±0.03 mm) Note : Adjust the valve clearance while the engine is cold.		
Emissions Durability Period (California only)		500 hours		

Specifications are subject to change without notice.

\* : Electric starter model.

# 3. COMPONENTS

---

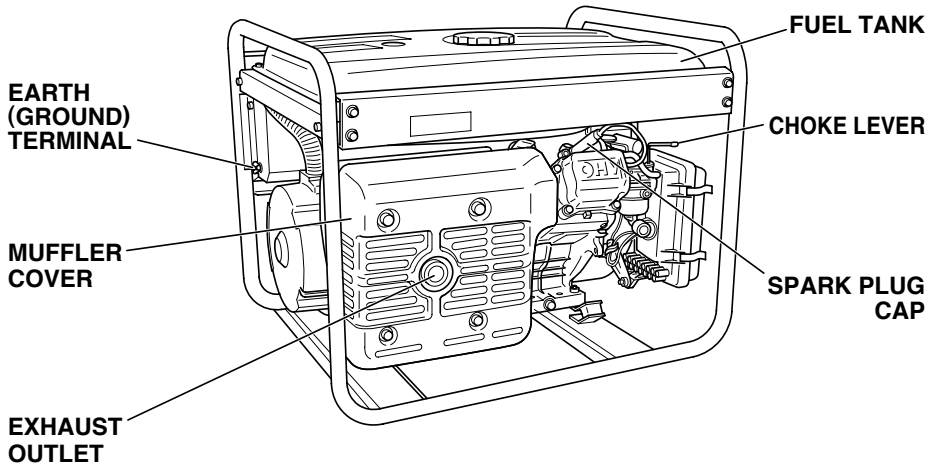
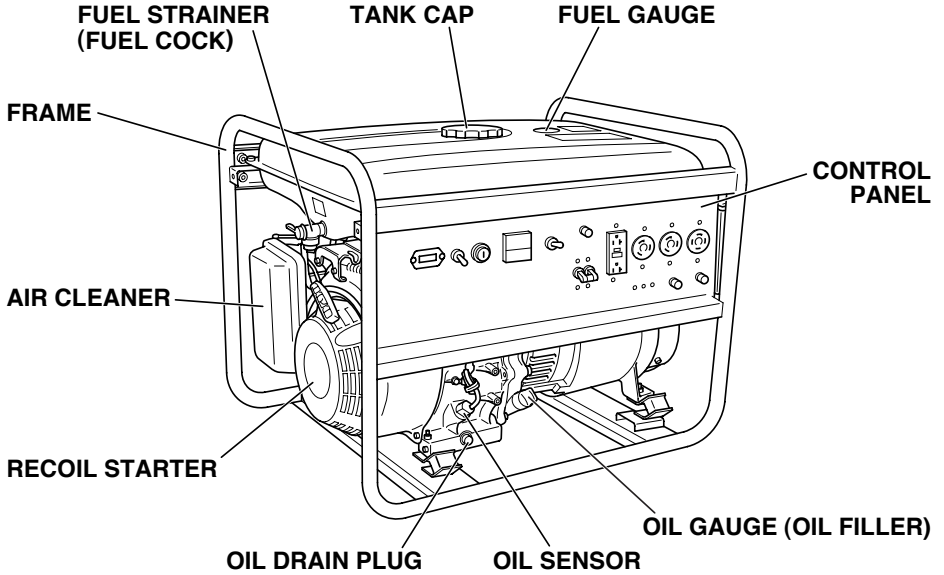

# 4. PRE-OPERATION CHECKS

## CHECK ENGINE OIL.

Before checking or refilling oil, be sure generator is located on stable and level surface with engine stopped.

- Remove oil filler cap and check the engine oil level.
- If oil level is below the lower level line, refill with suitable oil (see table) to upper level line. Do not screw in the oil filler cap when checking oil level.
- Change oil if contaminated. (See "How-To" Maintenance.)

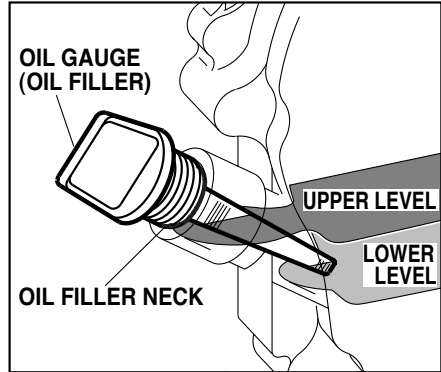

**Oil capacity : 0.32 US-gal  
(1.2 liters)**

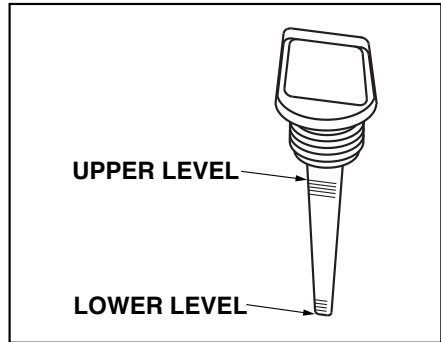

## Recommended engine oil :

Use 4-stroke automotive detergent oil of API service class SE or higher grade (SG, SH or SJ is recommended). SAE 10W-30 or 10W-40 is recommended for general, all-temperature use. If single viscosity oil is used, select the appropriate viscosity for the average temperature in your area.

Single grade	5W								
	10W								
Multigrade	20W								
	#20								
Ambient temperature	#30								
	#40								
	10W-30								
	10W-40								
	-20	-10	0	10	20	30	40°C		
	-4	14	32	50	68	86	104°F		



## CHECK ENGINE FUEL.

### **⚠ WARNING**

Do not refuel while smoking or near open flame or other such potential fire hazards. Otherwise fire accident may occur.

- Check fuel level at fuel level gauge.
- If fuel level is low, refill with automotive unleaded gasoline only.  
This engine is certified to operate on automotive unleaded gasoline.
- Be sure to use the fuel filter screen on the fuel filter neck.

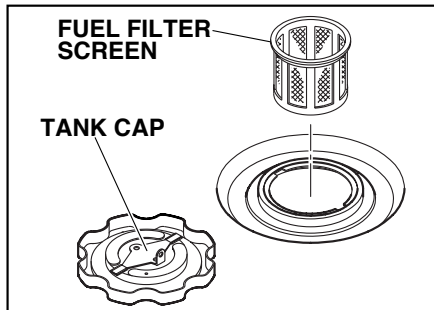

**Fuel tank capacity : 7.26 US-gal  
(27.5 liters)**

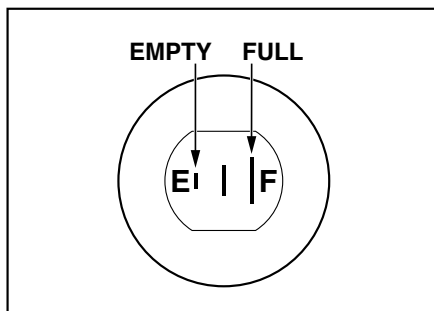

### **⚠ WARNING**

**Make sure you review each warning in order to prevent fire hazard.**

- Do not refill tank while engine is running or hot.
- Close fuel cock before refueling with fuel.
- Be careful not to admit dust, dirt, water or other foreign objects into fuel.
- Wipe off spilt fuel thoroughly before starting engine.
- Keep open flames away.

---

## CHECKING COMPONENT PARTS

Check following items before starting engine:

- Fuel leakage from fuel hose, etc.
- Bolts and nuts for looseness.
- Components for damage or breakage.
- Generator not resting on or against any adjacent wiring.

## CHECK GENERATOR SURROUNDINGS.

### **WARNING**

**Make sure you review each warning in order to prevent fire hazard.**

- **Keep area clear of in flammables or other hazardous materials.**
- **Keep generator at least 3 feet (1 meter) away from buildings or other structures.**
- **Only operate generator in a dry, well ventilated area.**
- **Keep exhaust pipe clear of foreign objects.**
- **Keep generator away from open flame. No smoking!**
- **Keep generator on a stable and level surface.**
- **Do not block generator air vents with paper or other material.**

## BATTERY INSTALLTION (Electric starter model)

Recommended Battery: A capacity of 12V-24AH or larger.

### WARNING

Death, personal injury and/or property damage may occur unless instructions are followed carefully.

- Use battery of recommended capacity.
- Turn the starter switch to the "STOP" position when mounting or dismanting battery. When mounting battery, connect the positive (+) cable first and then the negative (-) cable to the battery. Be careful not to short battery cables. When dismanting battery, disconnect negative (-) cable first.

RED CABLE : To positive (+) terminal

BLACK CABLE : To negative (-) terminal

- Should the connection be made in incorrect manner, the generator will be broken.
- Tighten bolts and nuts on terminals securely so they will not be loosened by vibration.
- Disconnect battery cables when charging battery.

### "HOW TO" INSTALL BATTERY (See "OPTIONAL PARTS")

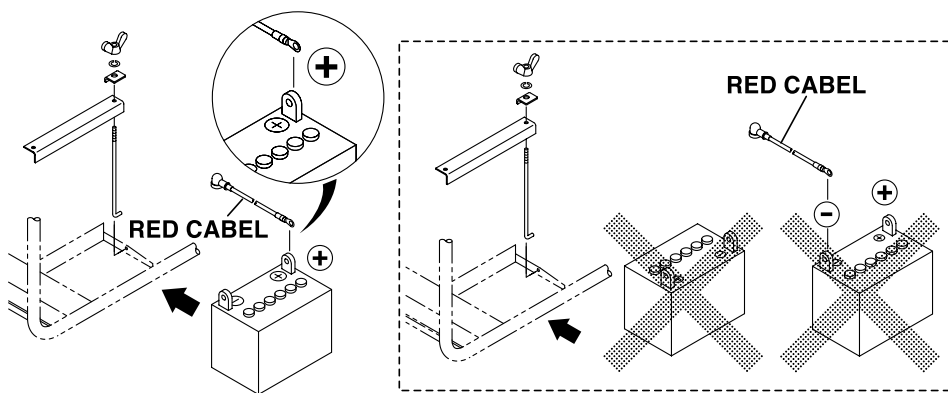

---

## GROUNDING THE GENERATOR

- To ground the generator to the earth, connect the grounding lug of the generator to the grounding spike driven into the earth or to the conductor which has been already grounded to the earth.
- If such grounding conductor or grounding electrode is unavailable, connect the grounding lug of the generator to the grounding terminal of the using electric tool or appliance.

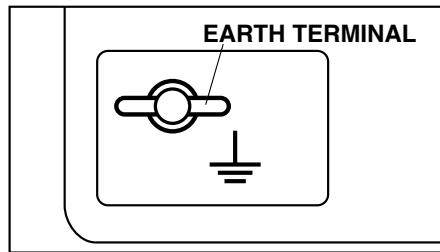
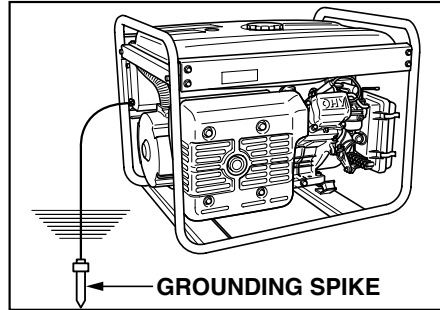

# 5. OPERATING PROCEDURES

## STARTING THE ENGINE

### [CAUTION]

Check the oil level before each operations as outlined on page 6.

- (a) Turn the engine switch to the position "ON". (Recoil starter model only)
- (b) Turn the no-fuse breaker to the "OFF" position.
- (c) Open the fuel cock.
- (d) Turn the choke lever to close if the engine is cold.

### (e) [Recoil starter model]

Pull the starter handle slowly until resistance is felt.

This is the "compression" point. Return the handle to its original position and then pull swiftly.

- If the engine fails to start after several attempts, repeat above procedures with choke knob returned to open.
- Do not fully pull out the rope.
- After starting, allow the starter handle to return to its original position while still holding the handle.

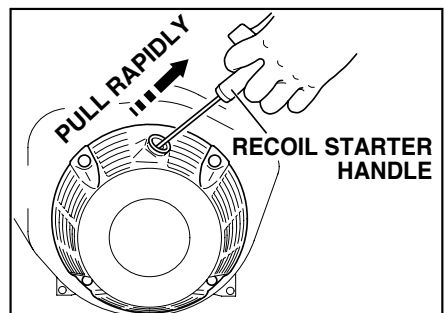
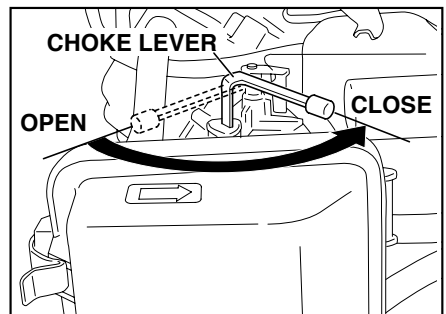
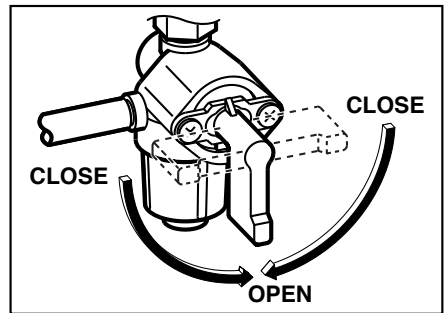
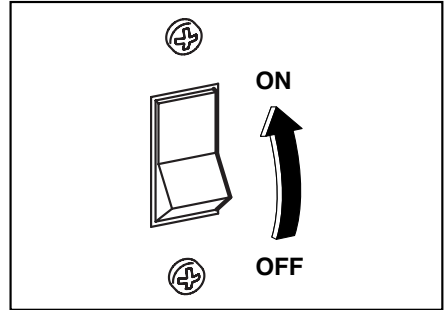

(f) **[Electric starter model]**

Insert the key into the key switch and turn it clockwise to the "RUN" position to start the engine.

Then turn the key further to the "START" position. The engine will be started by starting motor.

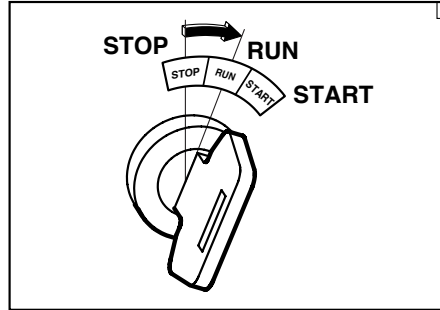

**[CAUTION]**

- Do not run the starting motor over 5 seconds continuously. If the engine fails to start, return the key to the "RUN" position and wait about 10 seconds then start again.
- Do not turn the key switch to "START" when the engine is running to prevent damage of starting motor.
- Do not turn the key switch to "START" position when the engine is running to prevent damage of starting motor.
- When starting the engine by recoil starter, set the key switch at the "ON" position and pull the starter handle.

(g) After the engine started, return the choke lever gradually to "OPEN" position.

(h) Warm up the engine without a load for a few minutes.

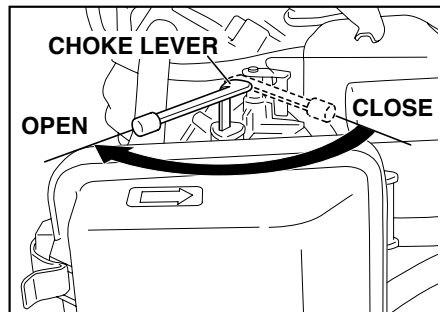

## USING ELECTRIC POWER

### **⚠ WARNING**

- Make sure that the appliance is switched OFF before connecting it to the generator.
- Do not move the generator while it is running.
- Be sure to ground the generator if the connected appliance is grounded. Failure to ground unit may lead to electrical shock.

## CONTROL PANEL

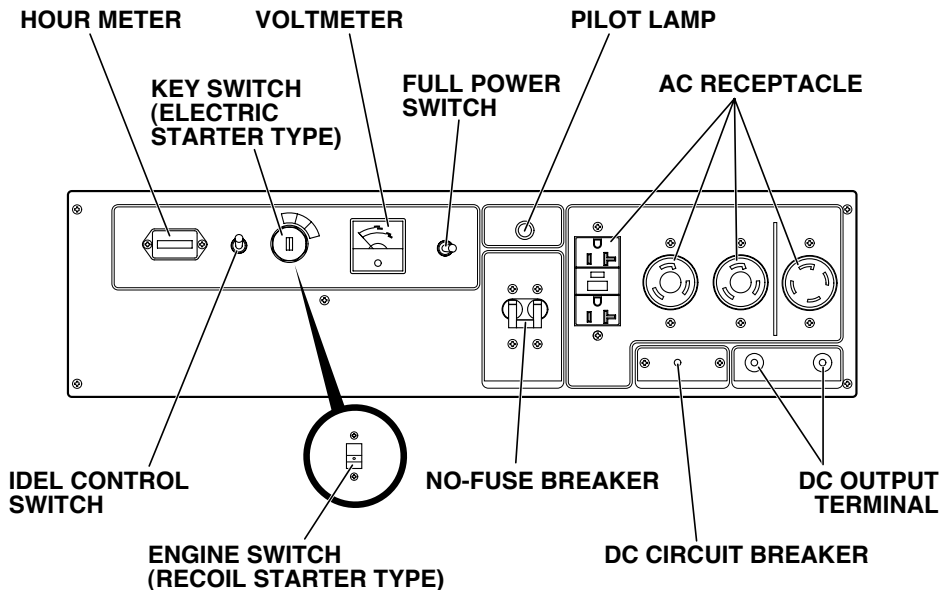

## (1) AC APPLICATION

- (a) Check the voltmeter for proper voltage.
- This generator is thoroughly tested and adjusted in the factory. If the generator does not produce the specified voltage, consult your nearest Robin dealer or service shop.
- (b) Turn off the switch (es) of the electrical appliance (s) before connecting to the generator.
- (c) Insert the plug (s) of the electrical appliance(s) into the receptacle.
- Check the amperage of the receptacles used referring to **TABLE 1**, and be sure not to take a current exceeding the specified amperage.
  - Be sure that the total wattage of all appliances dose not exceed the rated output of the generator.
- (d) Turn the breaker on to see if the pilot lamp lights up.
- (e) Turn on the switch of the appliance.

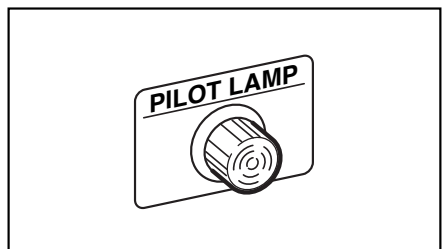
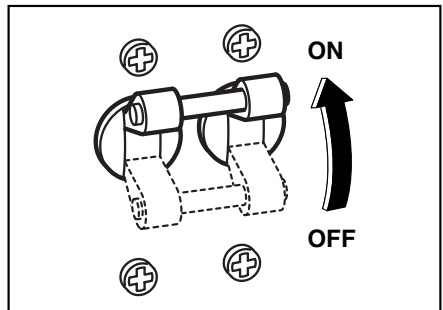
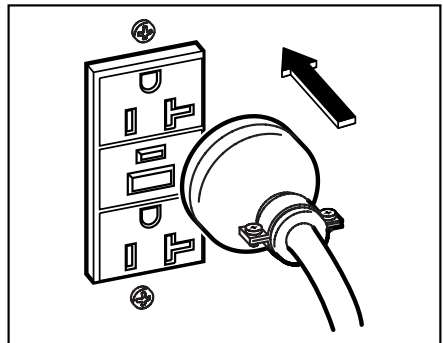
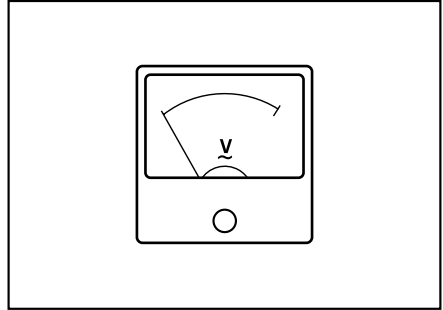







Style	Ampere	Receptacle	AC plug	Description
	up to 20A	NEMA 5-20A	NEMA 5-20P	GFCI (Ground Fault Circuit Interrupter) Receptacle, duplex (REC1)
	up to 20A	NEMA L5-20R	NEMA L5-20P	Locking Receptacle (REC2)
	up to 30A	NEMA L5-30R	NEMA L5-30P	Locking Receptacle (REC3)
	up to 30A	NEMA L14-30R	NEMA L14-30P	Locking Receptacle (REC4)

TABLE 1

**⚠ WARNING**

- To take power out from the **TWIST LOCK RECEPTACLE**, insert the plug into the receptacle, and turn it clockwise to the lock position.
- Be sure to ground the generator if the connected electrical device is grounded.

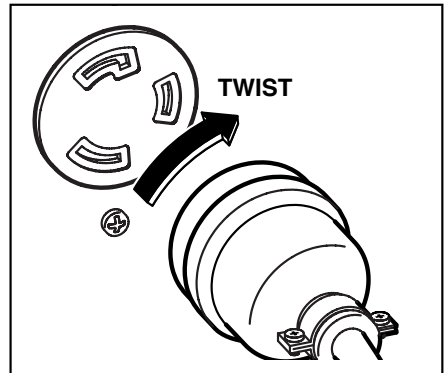

**NOTE :**

When the no-fuse breaker turns off during operation, the generator is over loaded or the appliance is defective. Stop the generator immediately, check the appliance and / or generator for overloading or detect and have repaired as necessary by Robin dealer or service shop.

**[CAUTION]**

The duplex 120V receptacle is protected by a GFCI (Ground Fault Circuit Interrupter). GFCI shuts off the output current from the duplex 120V receptacle when a ground fault occurs in the generator or the appliance. Please note that other receptacles are not protected by GFCI.

## GFCI RECEPTACLE

After starting the engine, check the GFCI for proper functioning by the following test procedure.

- Push blue TEST button, The red RESET button will pop out exposing the word TRIP. Power is now off at the outlets protected by the GFCI, indicating that the device is functioning properly.
- If TRIP dose not appear when testing, do not use the generator. Call a qualified electrician.
- To restore power, push RESET button.

### **⚠ WARNING**

If the RESET button pops out during operation, stop the generator immediately and call a qualified electrician for checking generator and the appliances.

## FULL POWER SWITCH

Select the voltage using the FULL POWER SWITCH in accordance with the electrical appliance. Refer to **TABLE 2**.

### **[CAUTION]**

Change the FULL POWER SWITCH after turning the no-fuse breaker to "OFF".

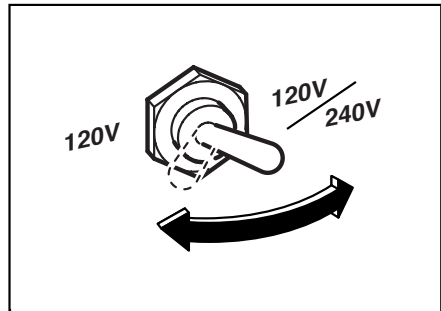

## NOTE :

Voltmeter always indicates the lower voltage whichever the FULL POWER SWITCH is set.

Switch position	Lower Voltage Receptacle	Higher Voltage Receptacle
120V	Activated full rated output	N.A
120/240V	Activated half of rated output	Activated full rated output

TABLE 2

## (2) CONNECTING TO DOMESTIC CIRCUITS (HOUSE WIRING)

### **⚠ WARNING**

**This generator is neutral grounded type.**

**If a generator is to be connected to residential or commercial power lines, such as a stand-by power source during power outage, all connections must be made by a licensed electrician.**

**Failure in connection may result in death, personal injury, damage to generator, damage to appliances, damage to the building's wiring or fire.**

(a) When connecting a Robin generator to a house wiring, generator output power must be taken from the 240V-4P receptacle.

(b) Install a transfer switch.

A transfer switch must be installed to transfer the load from the commercial power source to the generator. This switch is necessary to prevent accidents caused by the recovery from power outage. Use a transfer switch of the correct capacity. Install transfer switch between the meter and the fuse or AC breaker box.

### **[CAUTION]**

**If the neutral wire of house wiring is grounded, be sure to ground the ground terminal of the generator. Otherwise an electric shock may occur to the operator.**

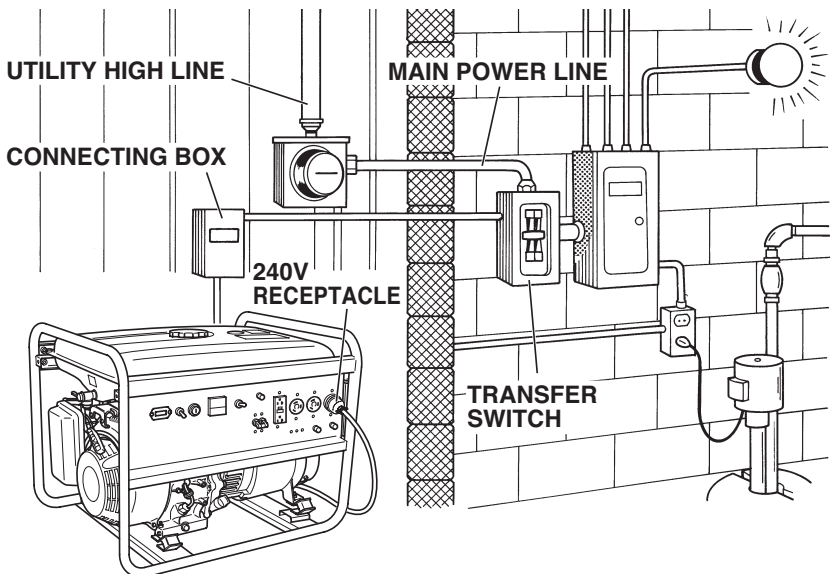

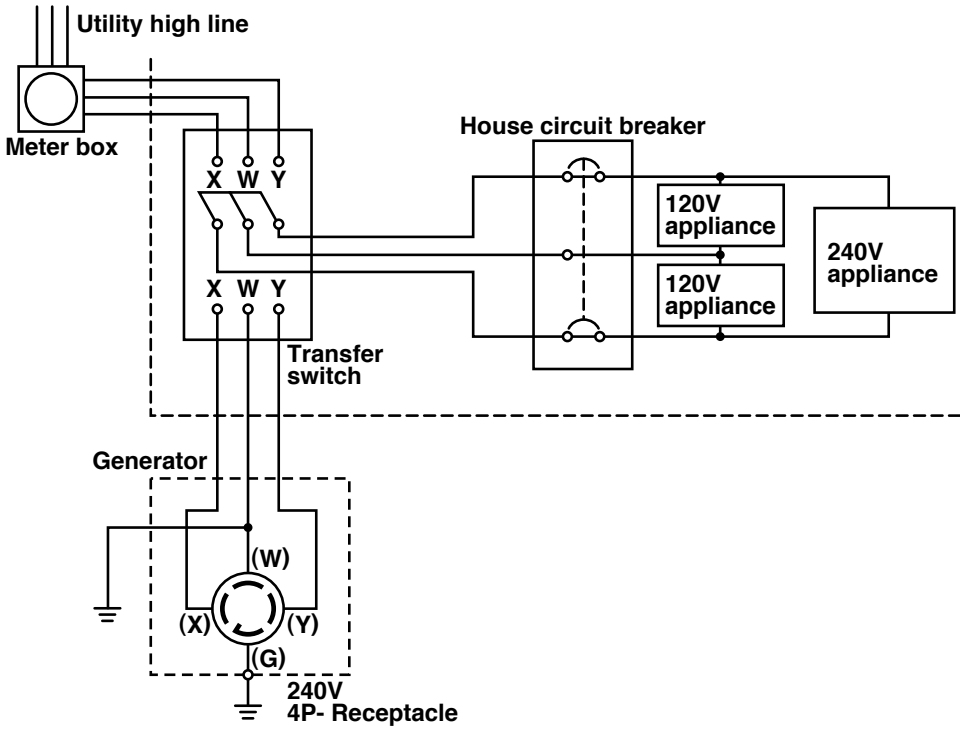

(c) Operating the generator.

- Set the full power switch to 120V/ 240V side.
- Turn the house AC breaker off before starting the generator.
- Start the generator and warm it up.
- Turn the house AC breaker on.

**[CAUTION]**

**Do not start the generator with electrical appliance (s) connected and with their switches on.**

**Otherwise the appliance (s) may be damaged by the surge voltage at starting.**

---

## IDLE CONTROL SWITCH

IDLE CONTROL SWITCH automatically reduces engine speed when load is OFF, and automatically increases engine speed to rated r.p.m. when load is ON.

IDLE CONTROL SWITCH provides fuel economy and low noise operation at no-load running.

### (1) HOW TO USE IDLE CONTROL SWITCH

- Start the engine with IDLE CONTROL SWITCH off.

#### **NOTE :**

Warm up the engine without a load for a few minutes.

- Turn IDLE CONTROL SWITCH on.

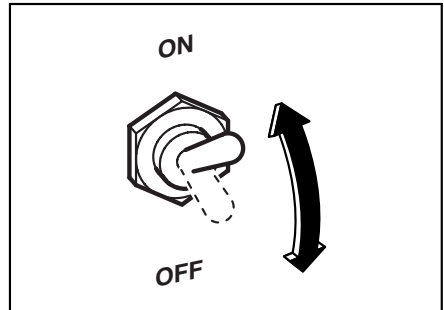

### (2) CHECKING THE OPERATION

When IDLE CONTROL SWITCH does not operate normally, please check following :

- Overloaded ?  
Please make it sure that the generator is not overload.

#### **NOTE :**

Most induction loads such as electric motors require three to five times more wattage than their ratings during starting.

This starting wattage should not exceed the rated output of the generator for proper operation of IDLE CONTROL SWITCH.

- Turn IDLE CONTROL SWITCH off when the IDLE CONTROL SWITCH does not work normally under the rated output.

#### **NOTE :**

The IDLE CONTROL SWITCH may not operate when the applied load is under 40W. In such cases turn the IDLE CONTROL SWITCH off.

### (3) STOPPING THE ENGINE

- Turn off the switch of load.
- Switch off generator's AC breaker.
- Disconnect tool or appliance.
- Turn the IDLE CONTROL SWITCH off.
- Turn the STOP SWITCH to the position "O" (OFF).

#### **NOTE :**

Allow the engine about 3 minutes to cool down at no-load before stopping.

---

## (2) DC APPLICATION

The DC terminal is used only for charging 12 volt batteries. It provides up to 12V-8.3A (100W) of maximum power.

### CONNECTION OF CABLE :

- Connect positive (red) terminal on generator to positive (+) terminal on battery.
- Connect negative (black) terminal on generator to negative (-) terminal on battery.
- Both AC and DC output can be used at the same time if the total output is within rated output of the generator.

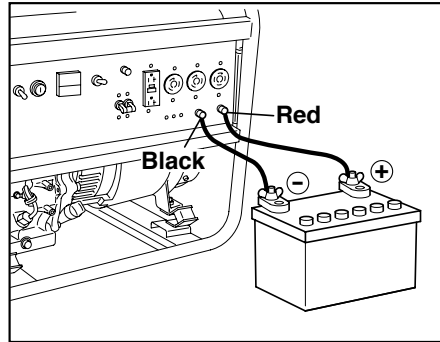

### SAFETY PRECAUTIONS WHILE CHARGING

- An explosive hydrogen gas is discharged through vent holes in the battery during the charging process. Do not allow spark or open flame around the generator or battery during the charging process.
- Electrolyte fluid can burn eyes and clothing. Be extremely careful to avoid contact. If injured, wash the affected area immediately with large quantities of water and consult a doctor for treatment.
- When charging a large capacity battery or totally discharged battery, excessive current may force the DC breaker to turn off. In such cases, use a battery charger to charge a large battery with AC output.
- Battery defects may cause the DC breaker to turn off. Check the battery before replacing the DC breaker.

## STOPPING THE GENERATOR

- (a) Turn off the power switch of the electric equipment and unplug the cord from receptacle of the generator.
- (b) Turn the no-fuse breaker to the "OFF" position.
- (c) Allow the engine about 3 minutes to cool down at no-load before stopping.
- (d) **[Recoil starter model]**

Turn the engine switch to the position "OFF".

### **[Electric starter model]**

Turn the key switch to the STOP position.

- (e) Close the fuel cock.

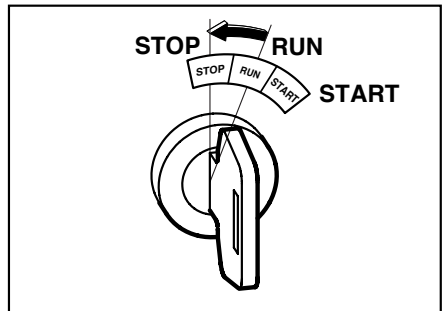
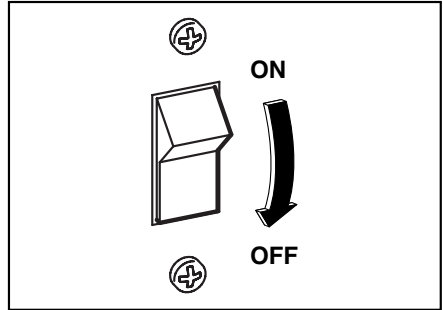

## OIL SENSOR

- (a) The oil sensor detects the fall in oil level in the crankcase and automatically stops the engine when the oil level falls below a predetermined level.
- (b) When engine has stopped automatically, switch off generator's no-fuse breaker, and check the oil level.  
Refill engine oil to the upper level as instructed on page 6 and restart the engine.
- (c) If the engine does not start by usual starting procedures, check the oil level.

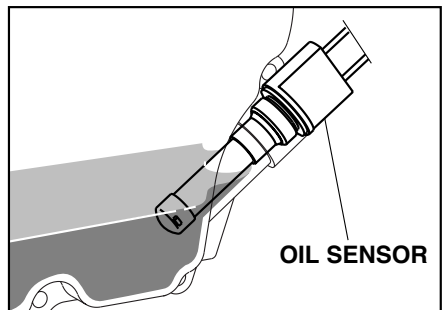
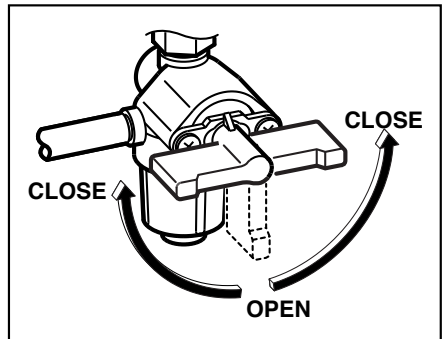

### **[CAUTION]**

**Do not remove OIL SENSOR PROBE when refilling with oil. Remove oil filler cap on the opposite side of carburetor.**

# 6. WATTAGE INFORMATION

---

Some appliances need a "surge" of energy when starting.

This means that the amount of electrical power needed to start the appliance may exceed the amount needed to maintain its use.

Electrical appliances and tools normally come with a label indicating voltage, cycles / Hz, amperage (amps) and electrical power needed to run the appliance or tool.

Check with your nearest dealer or service center with questions regarding power surge of certain appliances or power tools.

- Electrical loads such as incandescent lamps and hot plates require the same wattage to start as is needed to maintain use.
- Loads such as fluorescent lamps require 1.2 to 2 times the indicated wattage during start-up.
- Loads for mercury lamps require 2 to 3 times the indicated wattage during start-up.
- Electrical motors require a large starting current. Power requirements depend on the type of motor and its use. Once enough "surge" is attained to start the motor, the appliance will require only 50% to 30% of the wattage to continue running.
- Most electrical tools require 1.2 to 3 times their wattage for running under load during use. For example, a 5,000 watt generator can power a 1800 to 4000 watt electrical tool.
- Loads such as submersible pumps and air compressors require a very large force to start. They need 3 to 5 times the normal running wattage in order to start.  
For example, a 5,000 watt generator would only be able to drive a 1,000 to 1,700 watt pump.

## NOTE :

The following wattage chart is general guide only. Refer to your specific appliance for correct wattage.

To determine the total wattage required to run a particular electrical appliance or tool, multiply the voltage figure of the appliance/tool by the amperage (amps) figure of same. The voltage and amperage (amps) information can be found on a name plate which is normally attached to electrical appliances and tools.

Applications	Applicable Wattage (W)
	60Hz
Incandescent lamp, Heater	6000
Fluorescent lamp, Electric tool	3000
Mercury lamp	2000
Pump, Compressor	1400



## VOLTAGE DROP IN ELECTRIC EXTENSION CORDS

When a long electric extension cord is used to connect an appliance or tool to the generator, a certain amount of voltage drop or loss occurs in the extension cord which reduces the effective voltage available for the appliance or tool.

The chart below has been prepared to illustrate the approximate voltage loss when an extension cord of 300 feet (approx. 100 meters) is used to connect an appliance or tool to the generator.

Nominal cross section	A.W.G.	Allowable current	No.of strands / strands dia.	Resistance	Current Amp.							Voltage drop
					1A	3A	5A	8A	10A	12A	15A	
mm <sup>2</sup>	No.	A	No./mm	Ω/100m	1A	3A	5A	8A	10A	12A	15A	
0.75	18	7	30/0.18	2.477	2.5V	8V	12.5V	—	—	—	—	
1.27	16	12	50/0.16	1.486	1.5V	5V	7.5V	12V	15V	18V	—	
2.0	14	17	37/0.26	0.952	1V	3V	5V	8V	10V	12V	15V	
3.5	12 to 10	23	45/0.32	0.517	—	1.5V	2.5V	4V	5V	6.5V	7.5V	
5.5	10 to 8	35	70/0.32	0.332	—	1V	2V	2.5V	3.5V	4V	5V	

# 7. SPARK ARRESTER

## SPARK ARRESTER

In a dry or wooded area, it is recommendable to use the product with a spark arrester. Some areas require the use of a spark arrester. Please check your local laws and regulations before operating your product.

The spark arrester must be cleaned regularly to keep it functioning as designed. A clogged spark arrester :

- Prevents the flow of exhaust gas
- Reduces engine output
- Increases fuel consumption
- Makes starting difficult

If the engine has been running, the muffler and the spark arrester will be very hot. Allow the muffler to cool before cleaning the spark arrester.

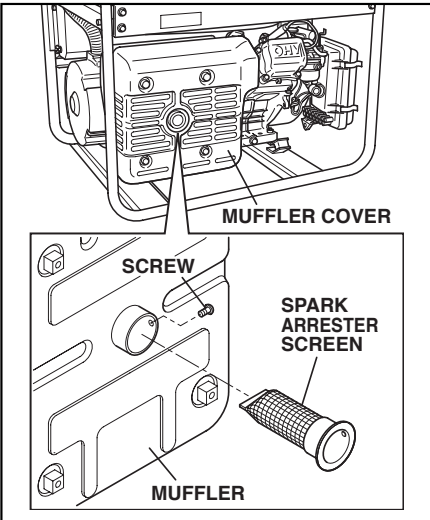

### How to remove the spark arrester

1. Remove the flange bolts from the muffler cover and remove the muffler cover.
2. Remove the special screw from the spark arrester and remove the spark arrester from the muffler.

### Clean the spark arrester screen

Use a brush to remove carbon deposits from the spark arrester screen. Be careful to avoid damaging the screen.

The spark arrester must be free of breaks and holes. Replace the spark arrester if it is damaged.

Install the spark arrester, and muffler protector in the reverse order of disassembly.

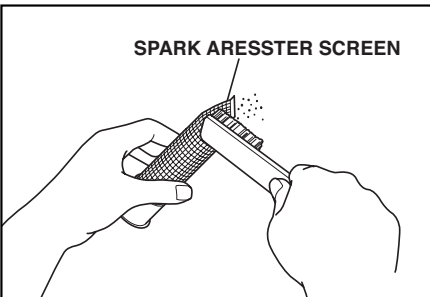

# 8. MAINTENANCE SCHEDULE

MAINTENANCE, REPLACEMENT OR REPAIR OF THE EMISSION CONTROL DEVICES AND SYSTEMS MAY BE PERFORMED BY ANY NONROAD ENGINE REPAIR ESTABLISHMENT OR INDIVIDUAL.

## DAILY INSPECTION

Before running the generator, check the following service items:

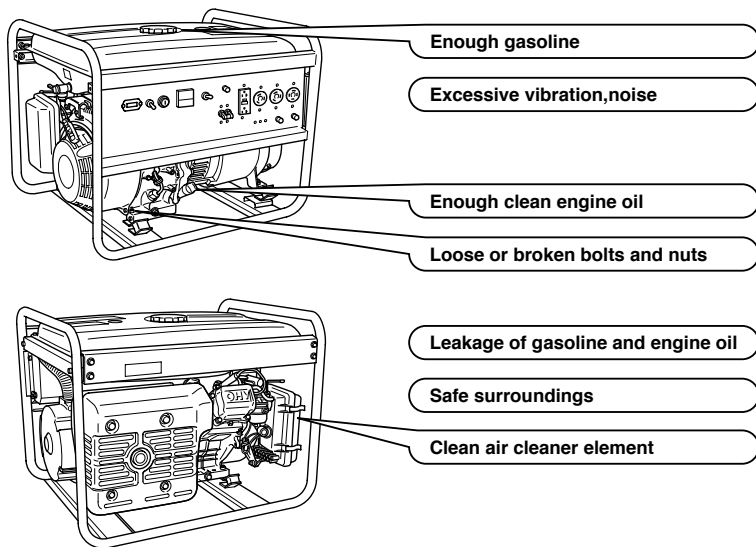

## PERIODIC MAINTENANCE

Periodic maintenance is vital to safe and efficient operation of your generator. Check the table below for periodic maintenance intervals.

**IT IS ALSO NECESSARY FOR THE USER OF THIS GENERATOR TO CONDUCT THE MAINTENANCE AND ADJUSTMENTS ON THE EMISSION-RELATED PARTS LISTED BELOW TO KEEP THE EMISSION CONTROL SYSTEM EFFECTIVE.**

The emission control system consists of the following parts :

- |   |  |  |
|---|--|--|
| (1) Carburetor and internal parts               | (4) Air cleaner elements                       | (8) Exhaust manifold, if applicable          |
| (2) Cold start enrichment system, if applicable | (5) Spark plug                                 | (9) Hoses, belts, connectors, and assemblies |
| (3) Intake manifold, if applicable              | (6) Magneto or electronic ignition system      |  |
|   | (7) Spark advance/retard system, if applicable |  |

The maintenance schedule indicated in the table is based on the normal generator operation. Should the generator be operated in extremely dusty condition or in heavier loading condition, the maintenance intervals must be shortened depending on the contamination of oil, clogging of filter elements, wear of parts, and so on.

## Periodic Maintenance Schedule table

Maintenance Items	Every 8 hours (Daily)	Every 20 hours	Every 50 hours (Weekly)	Every 200 hours (Monthly)	Every 500 hours	Every 1000 hours
CLEAN GENERATOR AND CHECK BOLT AND NUTS	● (Daily)					
CHECK AND REFILL ENGINE OIL	● (Refill daily up to upper level)					
CHANGE ENGINE OIL (*Note1)		● (Initial)	● (Every 100 hours)			
CLEAN SPARK PLUG			●			
CLEAN AIR CLEANER			●			
REPLACE AIR CLEANER ELEMENT				●		
CLEAN FUEL STRAINER				●		
CLEAN AND ADJUST SPARK PLUG AND ELECTRODES				●		
REPLACE SPARK PLUG					●	
SPARK ARRESTER			● (Every 100 hours)			
REMOVE CARBON FROM CYLINDER HEAD (*Note 2)					●	
CHECK AND ADJUST VALVE CLEARANCE (*Note 2)					●	
CLEAN AND ADJUST CARBURETOR (*Note 2)					●	
CLEAN AND REPLACE CARBON BRUSHES					●	
REPLACE FUEL LINES						● (Yearly)
OVERHAUL ENGINE (*Note 2)						●

\*Note: 1. Initial oil change should be performed after first twenty (20) hours of operation. Thereafter change oil every hundred (100) hours. Before changing oil, check for a suitable way to dispose of old oil. Do not pour it down into sewage drains, onto garden soil or into open streams. Your local zoning or environmental regulations will give you more detailed instructions on proper disposal.

\*Note: 2. As to the procedures for these items, please refer to the SERVICE MANUAL or consult your nearest Robin service dealer.

# 9. "HOW-TO" MAINTENANCE

## ENGINE OIL CHANGE

- Change engine oil every 100 hours.  
(For new engine, change oil after 20 hours.)
  - (a) Drain oil by removing the drain plug and the oil filler cap while the engine is warm.
  - (b) Reinstall the drain plug and fill the engine with oil until it reaches the upper level on the oil filler cap.
- Use fresh and high quality lubricating oil to the specified level as directed on page 6. If contaminated or deteriorated oil is used or the quantity of the engine oil is not sufficient, the engine damage will result and its life will be greatly shortened.

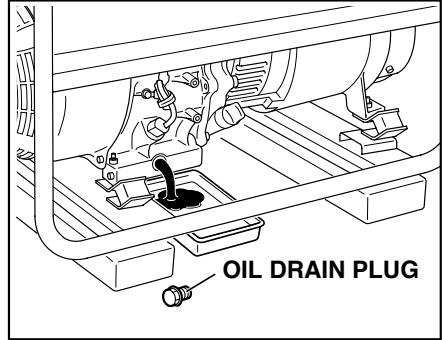

**Oil capacity . . . . 1.2 liters**

## CLEANING AIR CLEANER

**[CAUTION]**  
**Do not wash elements with kerosene, gasoline or oil.**

A dirty air cleaner element will cause starting difficulty, power loss, engine malfunctions, and shorten engine life extremely. Always keep the air cleaner element clean.

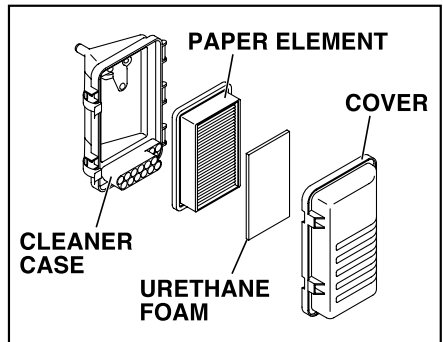

1. Urethane Foam Element  
Wash and clean the urethane foam with detergent. After cleaning, dry it.  
Clean the urethane foam element every 50 hours.
2. Paper element  
Clean by tapping gently to remove dirt and blow off dust.  
Never use oil. Clean the paper element every 50 hours of operation, and replace element set every 200 hours.

**Clean and replace air cleaner elements more often when operating in dusty environments.**

## CLEANING AND ADJUSTING SPARK PLUG

- (a) If the plug is contaminated with carbon, remove it using a plug cleaner or wire brush.
- (b) Check electrode gap.  
Adjust gap to 0.03 inches  
(0.7mm to 0.8mm).

Model	Spark plug
RGV7500	NGK BPR6ES

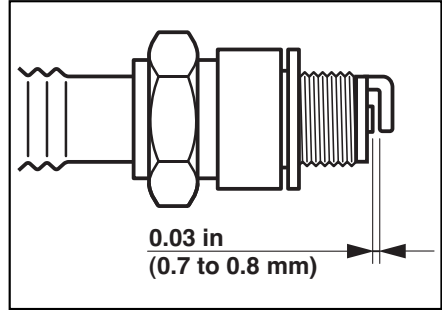

## CLEANING FUEL STRAINER

Dirt and water in the fuel are removed by the fuel strainer.

- (a) Remove the strainer cup and throw away water and dirt.
- (b) Clean the screen and strainer cup with gasoline.
- (c) Tightly fasten the cup to main body, making sure to avoid fuel leak.

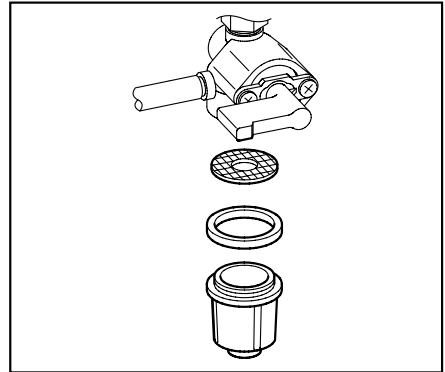

## FUEL HOSE REPLACEMENT

### WARNING

Take extreme caution when replacing fuel hose ; gasoline is flammable.

Replace the fuel hose every 1,000 hours or every year.

If fuel hose leak is found, replace the fuel hose immediately.

## CHECKING CARBON BRUSH

If the brush become excessively worn, its contact pressure with the slip ring changes and causes a roughened surface on the slip ring, resulting in irregular generator performance.

Check the brush every 500 hours or if generator performance is irregular.

If the brush is 0.2 in.(5 mm) long or less, replace it with a new one.

- (a) Remove the brush cover.
- (b) Disconnect the wire connector and remove the brush.
- (c) Carefully note the brush direction and relative position with the slip ring when installing new brush.

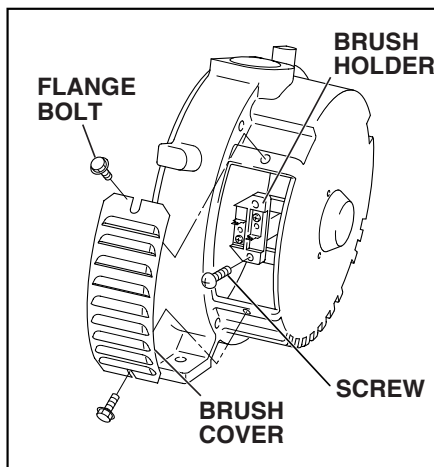
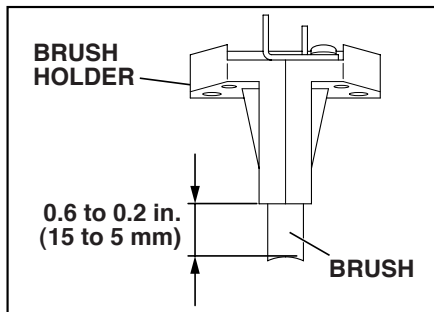

# 10. PREPARATION FOR STORAGE

---

The following procedures should be followed prior to storage of your generator for periods of 6 months or longer.

- Drain fuel from fuel tank carefully by disconnecting the fuel line. Gasoline left in the fuel tank will eventually deteriorate making engine-starting difficult.
- Remove the drain screw of the carburetor.
- Change engine oil.
- Check for loose bolts and screws, tighten them if necessary.
- Clean generator thoroughly with oiled cloth. Spray with preservative if available. **NEVER USE WATER TO CLEAN GENERATOR !**
- Pull starter handle until resistance is felt, leaving handle in that position.
- Store generator in a well ventilated, low humidity area.

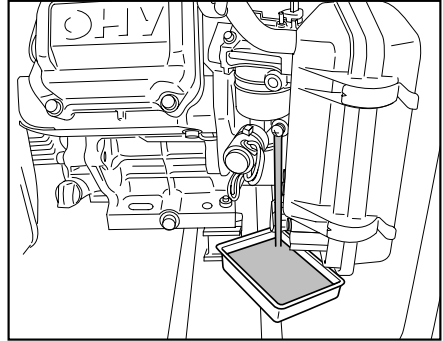



# 11. TROUBLESHOOTING

When generator engine fails to start after several attempts, or if no electricity is available at the output socket, check the following chart. If your generator still fails to start or generate electricity, contact your nearest Robin dealer or service shop for further information or corrective procedures.

## When Engine Fails to Start :

Check if choke lever is in its proper position.		Set the choke lever to "CLOSE" position.
Check if fuel cock is open.	↔	If closed, open fuel cock.
Check fuel level.		If empty, refill fuel tank making sure not to overfill.
Check if engine switch is in OFF.		Turn engine switch to ON.
Check to make sure generator is not connected to an appliance.		If connected, turn off the power switch on the connected appliance and unplug.
Check spark plug for loose spark plug cap.	↔	If loose, push spark plug cap back into place.
Check spark plug for contamination.		Remove spark plug and clean electrode.

## When No Electricity Is Generated at Receptacle :

Check to make sure no-fuse breaker is in the "ON" position.	↔	After making sure that the total wattage of the electrical appliance is within permissible limits and there are no defects in the appliance, turn the no-fuse breaker to the "ON" position. If breakers continue to actuate, consult your nearest servicing dealer.
Check AC and DC terminals for loose connection.		Secure connection if necessary.
Check to see if engine starting was attempted with appliances already connected to generator.	↔	Turn off switch on the appliance, and disconnect cable from receptacle. Reconnect after generator has been started properly.
Low power.		Carbon brushes are excessively worn

# 12. WIRING DIAGRAM

## Recoil starter model

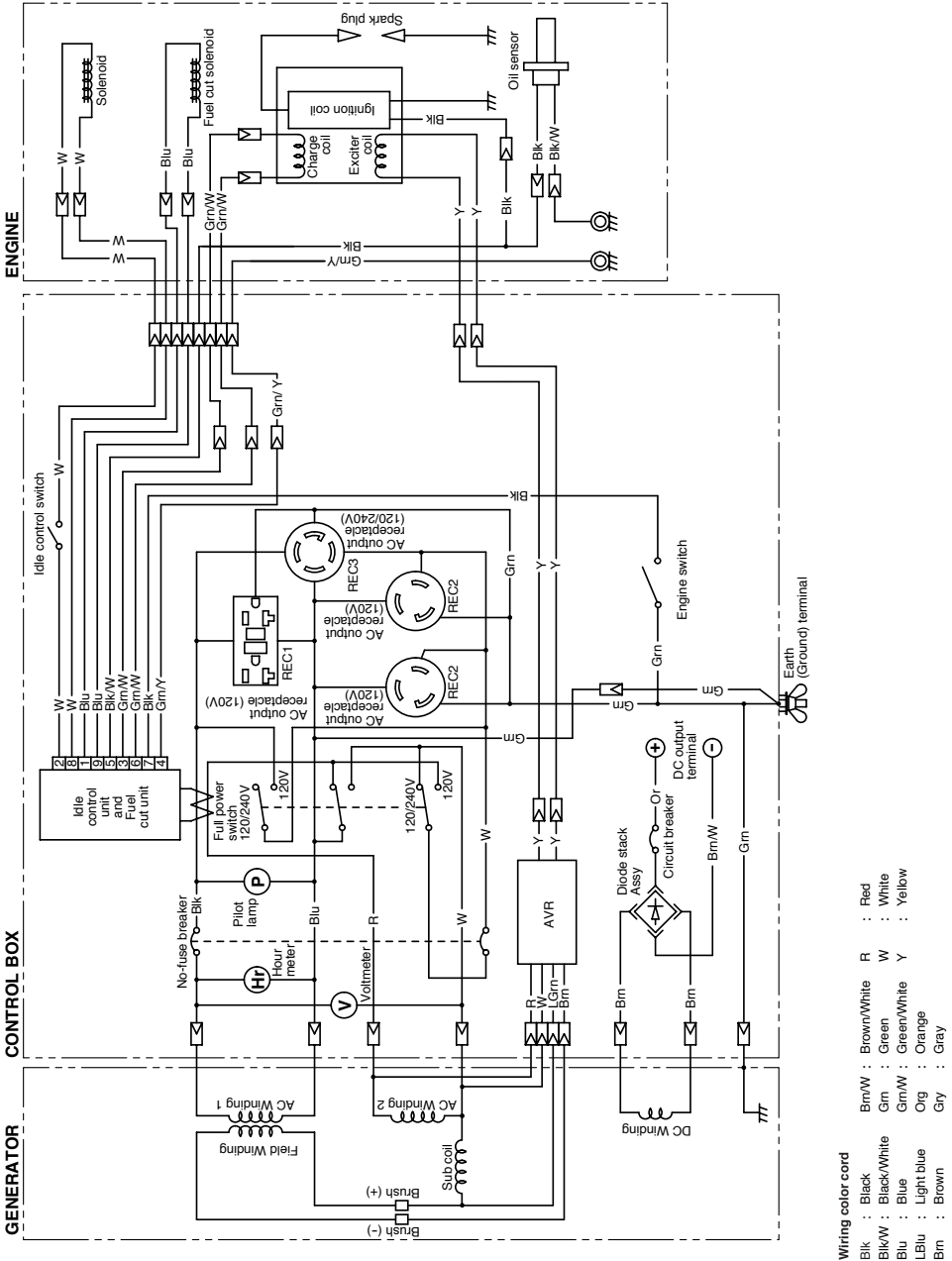

- Wiring color cord**
- Bk : Black
  - Bk/W : Black/White
  - Blu : Blue
  - LBlu : Light blue
  - Bm : Brown
  - Bm/W : Brown/White
  - Grn : Green
  - Grm/W : Green/White
  - Org : Orange
  - Bm : Brown
  - R : Red
  - W : White
  - Y : Yellow
  - Gr : Gray

# Electric starter model

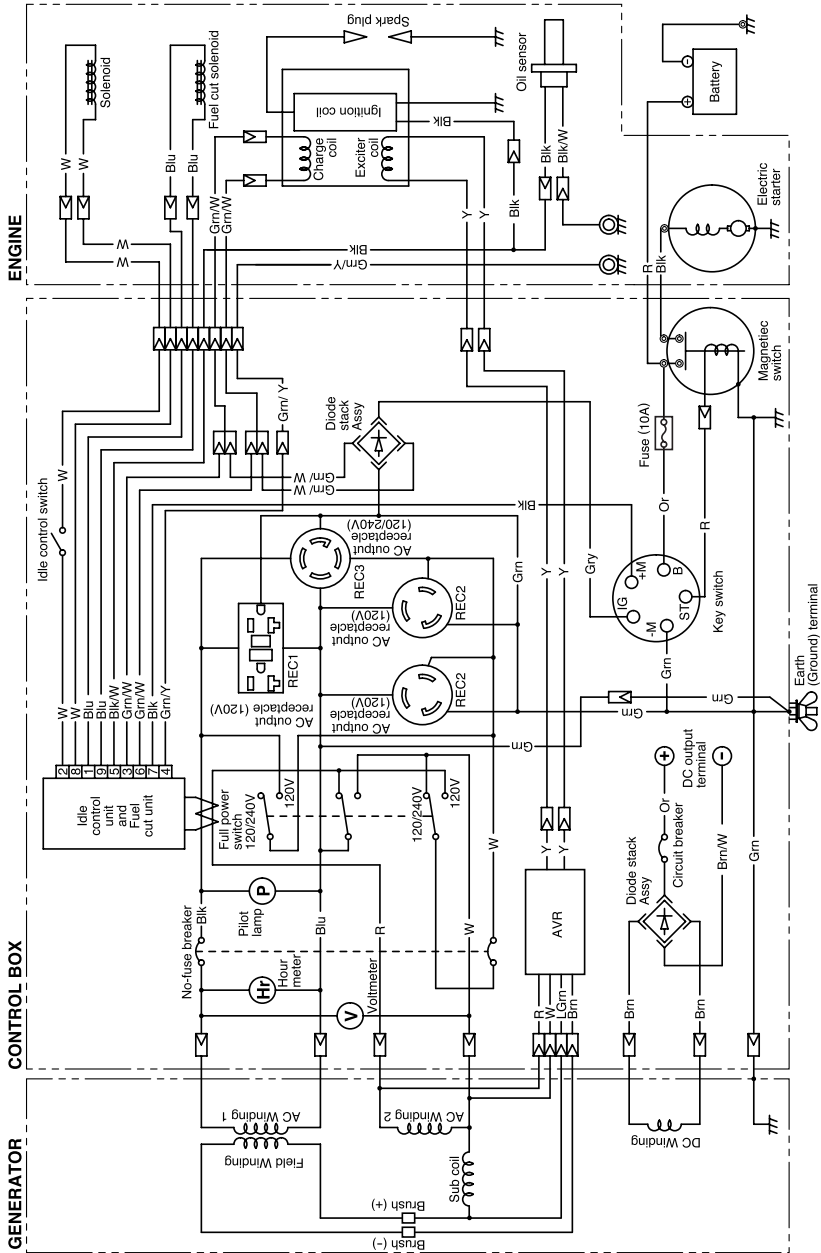

# 13. OPTIONAL PARTS

## HOW TO INSTALL THE WHEEL, HANDLE AND ROOF PIPE

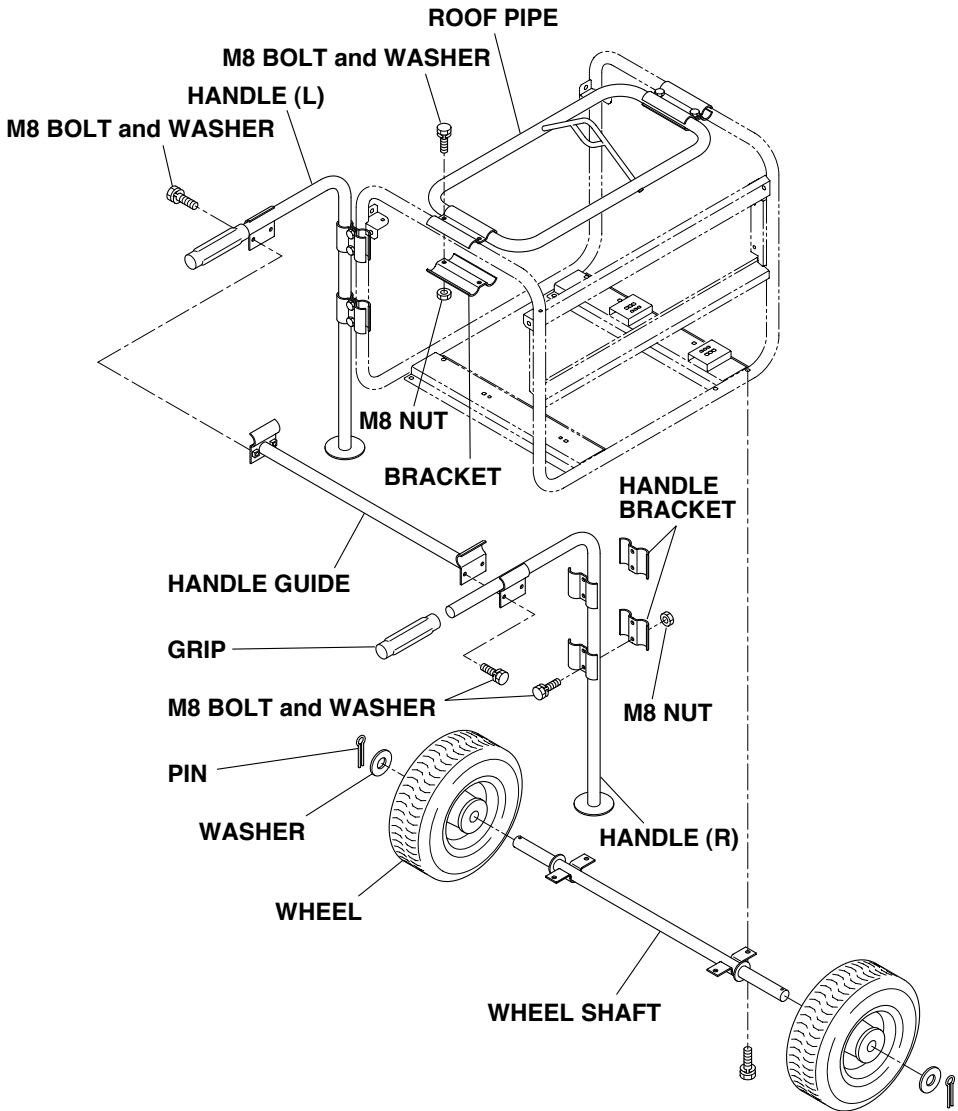

---

# HOW TO INSTALL THE BATTERY FRAME AND BATTERY (Electric starter type)

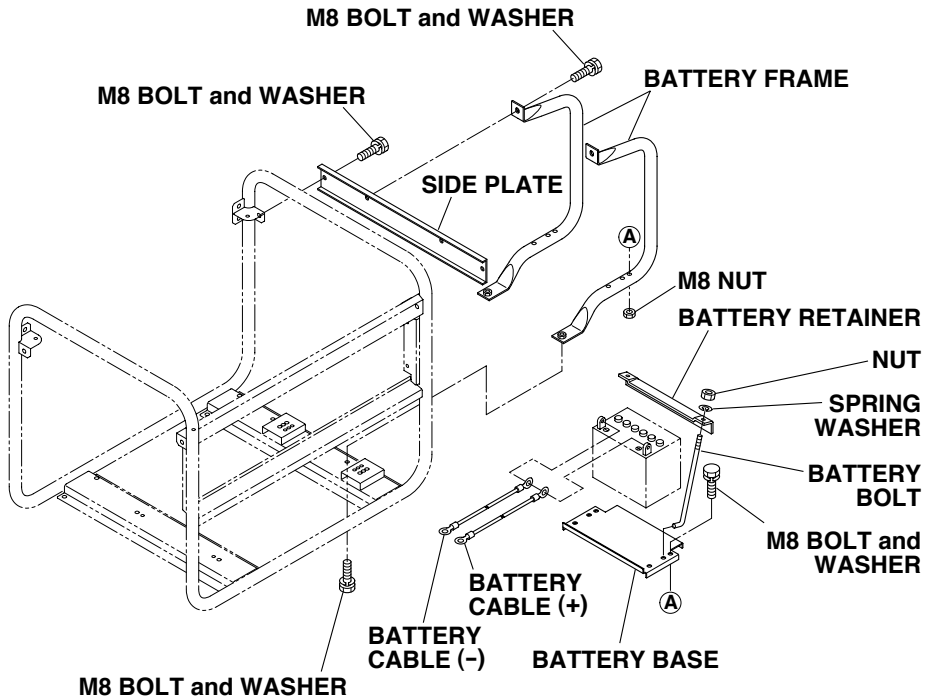

**FUJI HEAVY INDUSTRIES LTD.  
INDUSTRIAL PRODUCTS COMPANY**

4-410 Asahi, Kitamoto-shi,  
Saitama, 364-8511, Japan

Phone +81(48) 593-7798

Fax +81(48) 593-7946

Web site <http://www.fhi.co.jp/robin/>