

---

## INSTALLATION INSTRUCTIONS

---

Original Issue Date: **3/08**

Model: **8.5, 11, 12, 14, 15, 17, 18, 20, 30, and 48 kW Generator Sets**

Market: **Residential/Commercial**

Subject: **Maintenance Service Kits GM62345, GM62346, GM62347, GM62348, and GM83718**

### Introduction

This kit provides items necessary for general engine maintenance and service on 8.5–48 kW residential generator sets.

Read the entire installation procedure before beginning installation. Perform the steps in the order shown.

Kit Number	Generator Set, kW
GM62345	8.5
GM62346	12, 14
GM62347	17/18, 20
GM62348	15, 30
GM83718	48

**Figure 1** Kits

### Safety Precautions

Observe the following safety precautions while installing the kit.

---

#### ⚠ WARNING



**Accidental starting.  
Can cause severe injury or death.**

Disconnect the battery cables before working on the generator set. Remove the negative (-) lead first when disconnecting the battery. Reconnect the negative (-) lead last when reconnecting the battery.

---

**Disabling the generator set. Accidental starting can cause severe injury or death.** Before working on the generator set or connected equipment, disable the generator set as follows: (1) Move the generator set master switch to the OFF position. (2) Disconnect the power to the battery charger. (3) Remove the battery cables, negative (-) lead first. Reconnect the negative (-) lead last when reconnecting the battery. Follow these precautions to prevent starting of the generator set by an automatic transfer switch, remote start/stop switch, or engine start command from a remote computer.

# Installation Procedure

## Oil and Oil Filter

1. A drain plug is located on the service side of the oil sump, opposite the starter.
2. Remove one oil drain plug and the oil fill cap/dipstick. Aim the drain tube into catch basin and open the valve near the oil sump. Allow ample time for complete drainage.
3. Close the valve and place the hose back in clip on bulkhead wall.
4. Remove the old filter and wipe off the adapter/base on the engine.
5. Place a new replacement filter in a shallow pan with the open end up. Pour new oil (provided) in through the threaded center hole. Stop pouring when the oil reaches the bottom of threads. Allow a minute or two for the oil to be absorbed by the filter material.
6. Apply a thin film of clean oil to the rubber gasket on the new oil filter.
7. Install new oil filter. Hand tighten filter clockwise until the rubber gasket contacts the adapter, then tighten the filter an additional 3/4-1 turn.
8. Fill the crankcase with the new oil to the *F* or *FULL* mark on the dipstick. Always check the level with the dipstick before adding more oil. Never operate the engine with the oil level below the *L* or *ADD* mark, or above the *F* or *FULL* mark. See Figure 2.

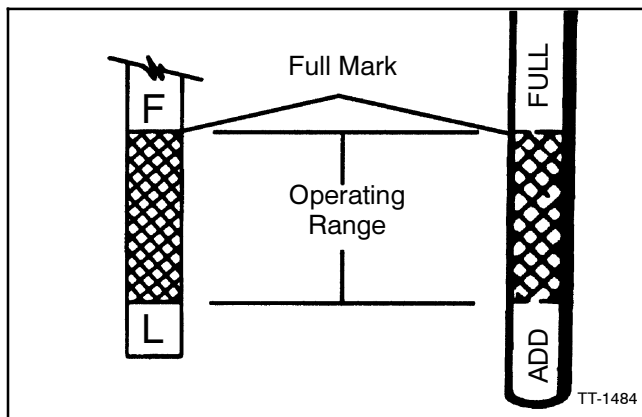

**Figure 2** Oil Level/Dipstick Detail

	8.5 kW	12, 14, 17/18, 20 kW	15/30 kW	48 kW
Spark plug gap, mm (in.)	0.51 (0.02)	0.76 (0.03)	0.8-0.9 (0.03-0.04)	0.89 (0.035)
Torque, Nm (ft. lb.)	24.4-29.8 (18-22)	24.4-29.8 (18-22)	25 (18)	25 (18)

**Figure 4** Spark Plug Gap and Torque

9. Reinstall the oil fill cap/dipstick and tighten securely.
10. Reconnect the negative battery cable and spark plug lead(s). Test run the engine, check for leaks and recheck oil level.

## Spark Plug

1. Before removing the spark plug(s), clean or blow out the area around the base of the plug(s) to keep dirt and debris out of the engine. Wear suitable eye protection, as required.
2. Using a 5/8 in. spark plug socket, remove and discard the old spark plug(s).
3. Check and set the gap of the new spark plug(s) using a wire feeler gauge. See Figure 4. Adjust the gap by carefully bending the ground electrode. See Figure 3.
4. Install the new spark plug(s) and torque as shown in Figure 4.

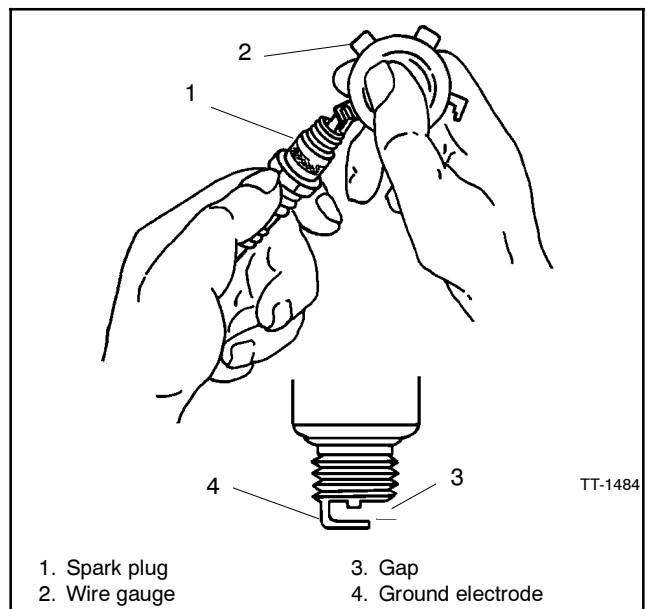
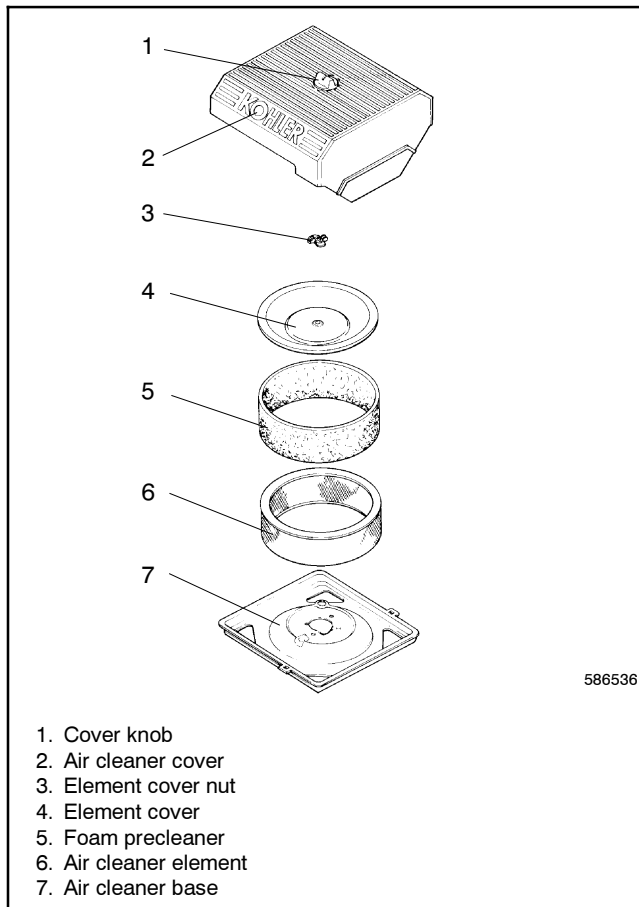

**Figure 3** Servicing Spark Plug

## Air Cleaner Element and Precleaner

### 8.5/12/14 kW

1. Loosen the cover retaining knob and remove the cover.
2. Remove and discard the old air cleaner element and precleaner (if equipped).
3. Install the precleaner over the new air cleaner element.
4. Install the paper element, precleaner, element cover, element cover nut, and the air cleaner cover.
5. Secure the cover with the cover retaining knob.



**Figure 5** Air Cleaner, 8.5/12/14 kW

### 17/18/20 kW

1. Loosen the two cover retaining knobs and remove the cover.
2. Rotate the air filter latch counterclockwise to unlock, then remove the paper element.
3. Install the paper element onto the air cleaner base. Make sure the element is flat and properly seated. Rotate the latch clockwise, over the molded lip on the element.
4. Install the air cleaner cover and secure with the two retaining knobs.

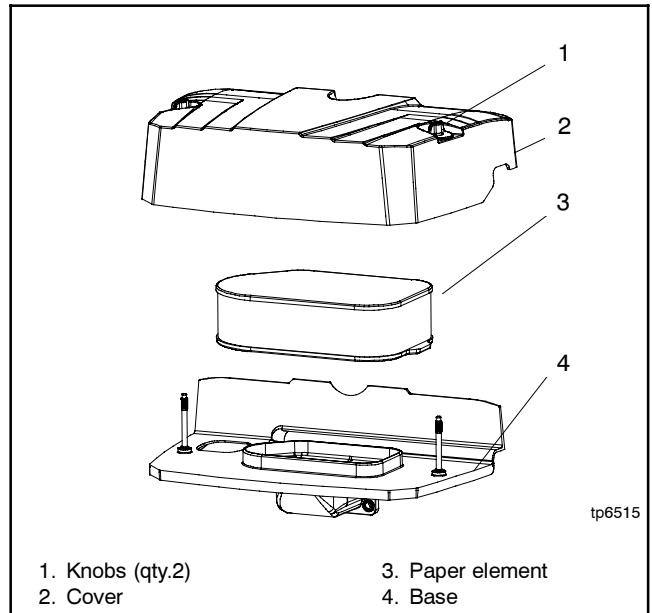

**Figure 6** Air Cleaner, 17/18/20 kW

### 15/30 kW

1. Release the spring clips to open the housing and remove the air silencer element.
2. Remove and discard the old air cleaner element.
3. Install the new element. Make sure the sealing surfaces fit correctly and reattach the spring clips.

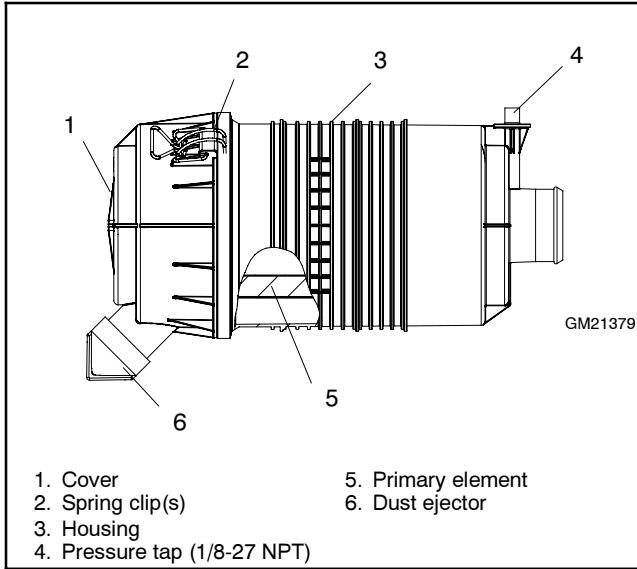

**Figure 7** Air Cleaner, 15/30 kW

### 48 kW

1. Remove the wingnut and remove the air cleaner retaining plate.
2. Remove and discard the old air cleaner element.
3. Install the new element.
4. Reinstall the retaining plate and secure with the wingnut.

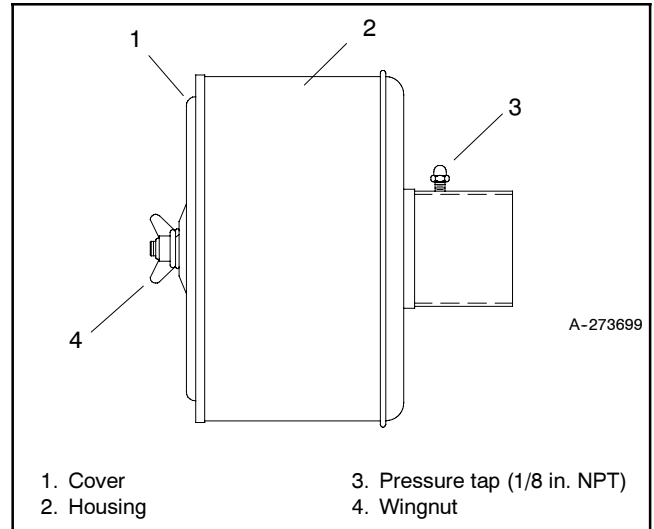

**Figure 8** Air Cleaner, 48 kW