

REV	DESCRIPTION	ECN#	DWN	APVD	DATE
1	PRELIMINARY DRAWING	3801	DMP	ACH	21NOV14

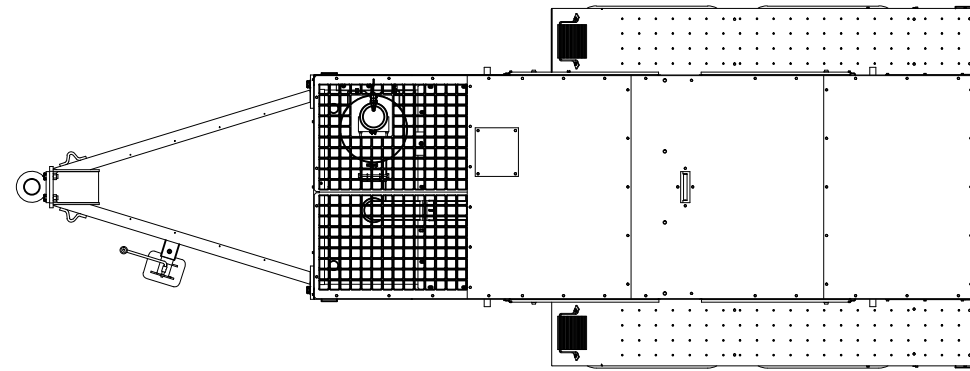

VIEW B
SEE SHEET 3 FOR ENLARGED VIEW

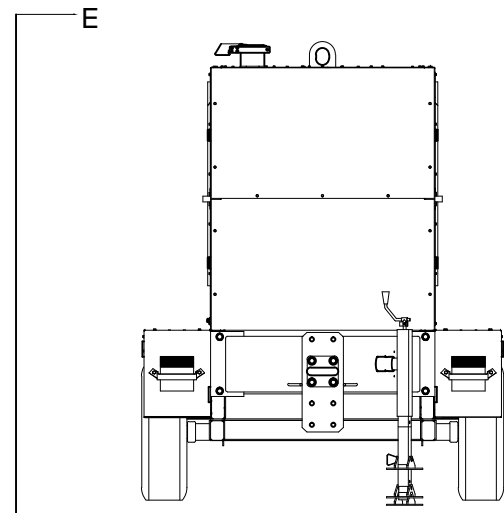

VIEW C
SEE SHEET 4 FOR ENLARGED VIEW

5
A3

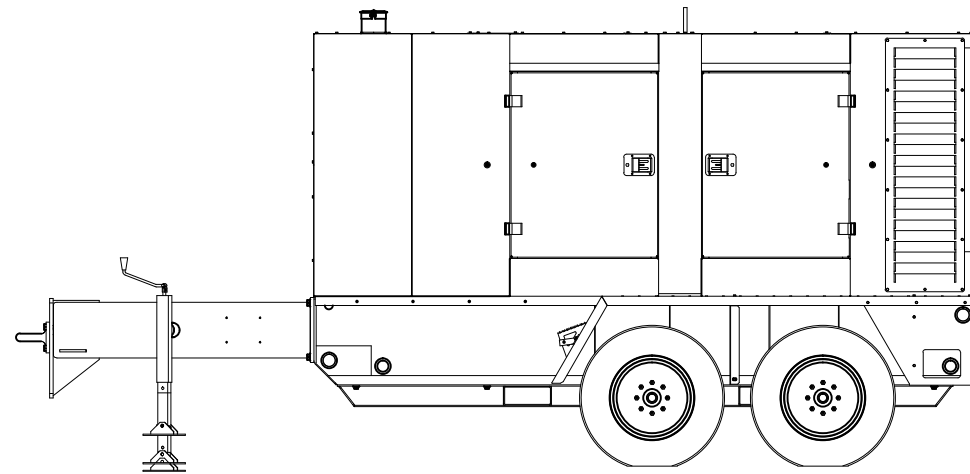

VIEW A
SEE SHEET 2 FOR ENLARGED VIEW

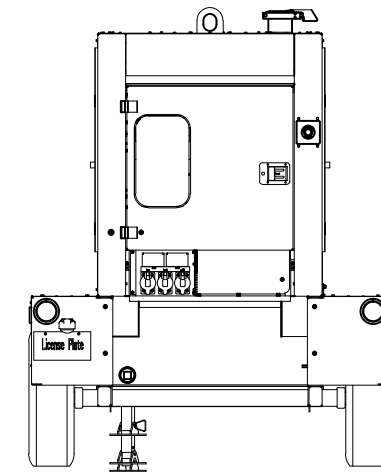

VIEW D
SEE SHEET 4 FOR ENLARGED VIEW

THIS DRAWING AND THE INFORMATION HEREON ARE OUR PROPERTY AND MAY BE USED BY OTHERS ONLY AS AUTHORIZED BY US. UNPUBLISHED-ALL RIGHTS RESERVED UNDER THE COPYRIGHT LAWS.		<input type="checkbox"/> YES <input checked="" type="checkbox"/> NO CONTROLLED DRAWING			
MACHINE TOLERANCES DECIMAL mm inch X. ±1.5 ±0.06 X.X ±0.8 ±0.03 X.XX ±0.3 ±0.01 X.XXX ±0.025 ±0.001 X.XXXX ±0.01 ANGULAR: ±0.5°		DRWN DPOTTER DATE 21NOV14 ENGR AHIGGINS		NAME GENERAL ARRANGEMENT, RC185D - RC240D	
FABRICATION TOLERANCES DECIMAL mm inch X. ±3 ±0.12 X.X ±1.5 ±0.08 ANGULAR: ±1.0°		MATERIAL AS NOTED SIMILAR TO --		PART NO. G131739 REV A	
		USED ONLY LAYOUT PART NO. --		UNITS INCH [MM]	
				PAGE 1 OF 6	

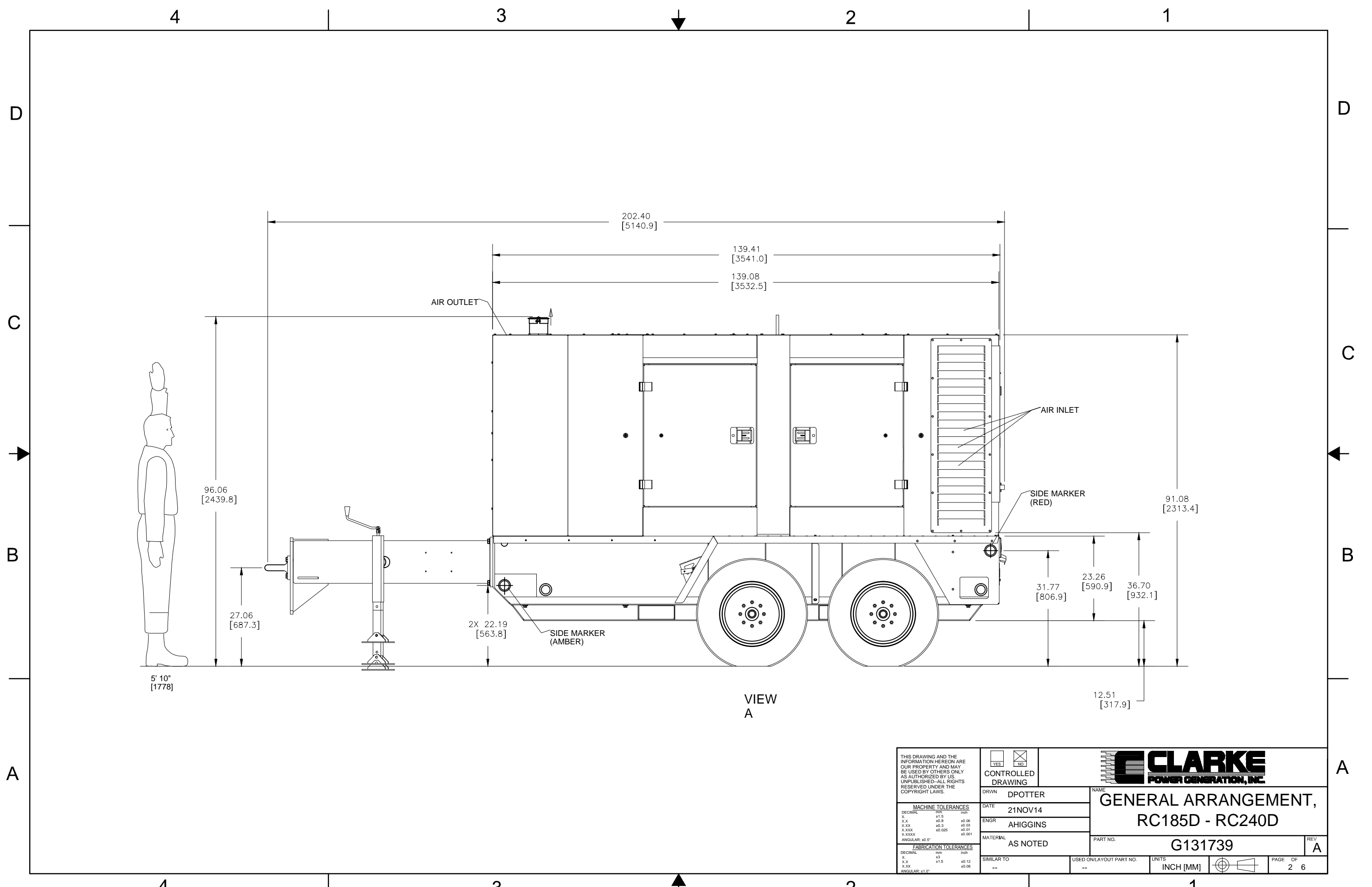

THIS DRAWING AND THE INFORMATION HEREON ARE OUR PROPERTY AND MAY BE USED BY OTHERS ONLY AS AUTHORIZED BY US. UNPUBLISHED-ALL RIGHTS RESERVED UNDER THE COPYRIGHT LAWS.		<input type="checkbox"/> YES <input checked="" type="checkbox"/> NO CONTROLLED DRAWING		NAME GENERAL ARRANGEMENT, RC185D - RC240D	
MACHINE TOLERANCES DECIMAL mm inch X ±1.5 ±0.06 X.X ±0.8 ±0.03 X.XX ±0.3 ±0.01 X.XXX ±0.025 ±0.001 X.XXXX ±0.01 ±0.001 ANGULAR: ±0.5°		DRWN DPOTTER DATE 21NOV14 ENGR AHIGGINS		PART NO. G131739	
FABRICATION TOLERANCES DECIMAL mm inch X ±3 ±0.12 X.X ±1.5 ±0.08 X.XX ±1.0 ±0.06 ANGULAR: ±1.0°		MATERIAL AS NOTED SIMILAR TO --	USED ONLY LAYOUT PART NO. --	UNITS INCH [MM]	PAGE OF 2 6

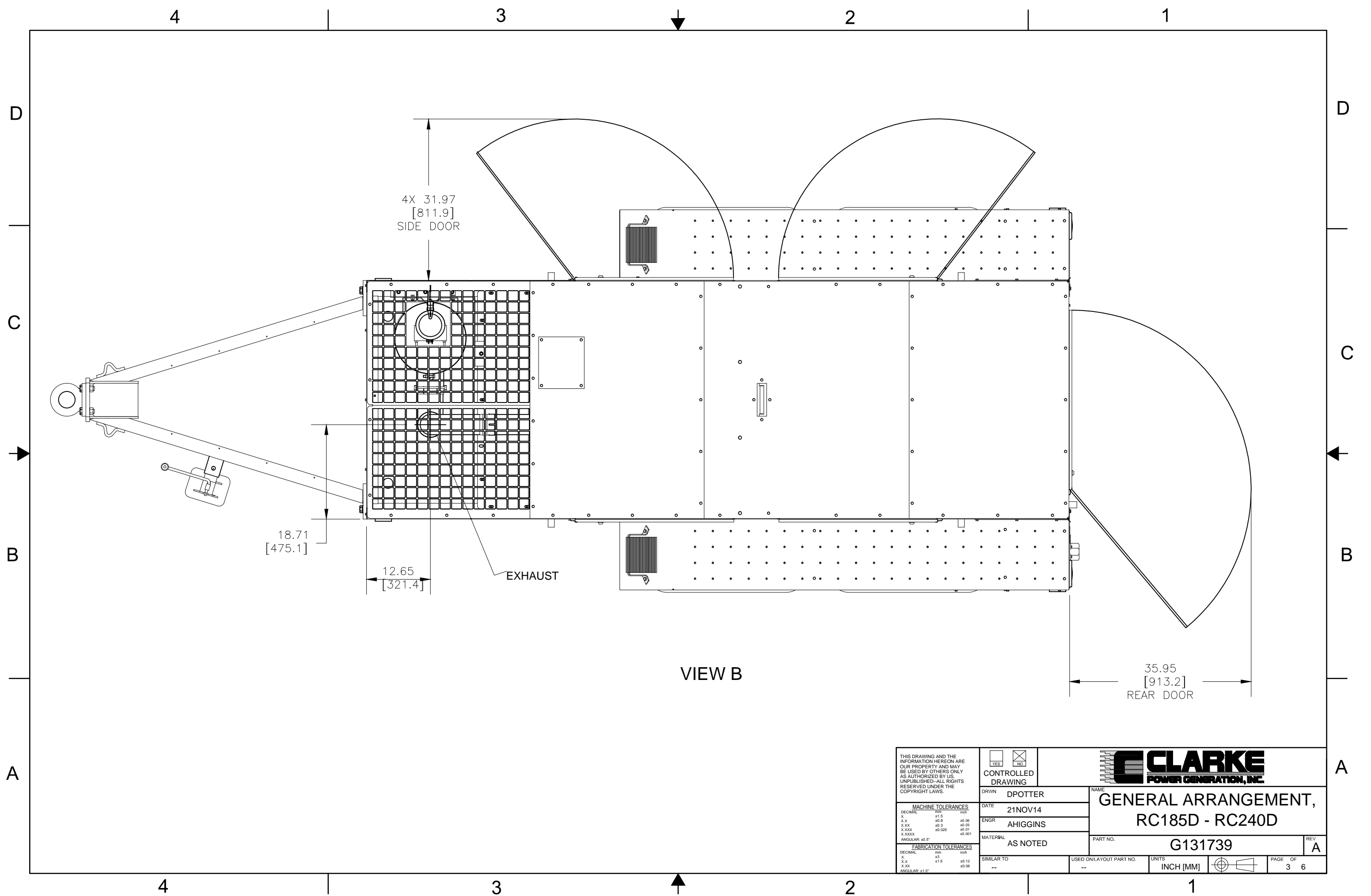

VIEW B

THIS DRAWING AND THE INFORMATION HEREON ARE OUR PROPERTY AND MAY BE USED BY OTHERS ONLY AS AUTHORIZED BY US. UNPUBLISHED-ALL RIGHTS RESERVED UNDER THE COPYRIGHT LAWS.		<input type="checkbox"/> YES <input checked="" type="checkbox"/> NO CONTROLLED DRAWING		NAME GENERAL ARRANGEMENT, RC185D - RC240D	
MACHINE TOLERANCES DECIMAL mm inch X ±1.5 ±0.06 X.X ±0.8 ±0.03 X.XX ±0.3 ±0.01 X.XXX ±0.025 ±0.001 X.XXXX ±0.001 ANGULAR: ±0.5°		DRWN DPOTTER DATE 21NOV14 ENGR AHIGGINS		PART NO. G131739	
FABRICATION TOLERANCES DECIMAL mm inch X ±3 ±0.12 X.X ±1.5 ±0.08 X.XX ±0.75 ±0.03 ANGULAR: ±1.0°		MATERIAL AS NOTED	USED ON LAYOUT PART NO. --	UNITS INCH [MM]	PAGE OF 3 6

4

3

2

1

D

D

C

C

B

B

A

A

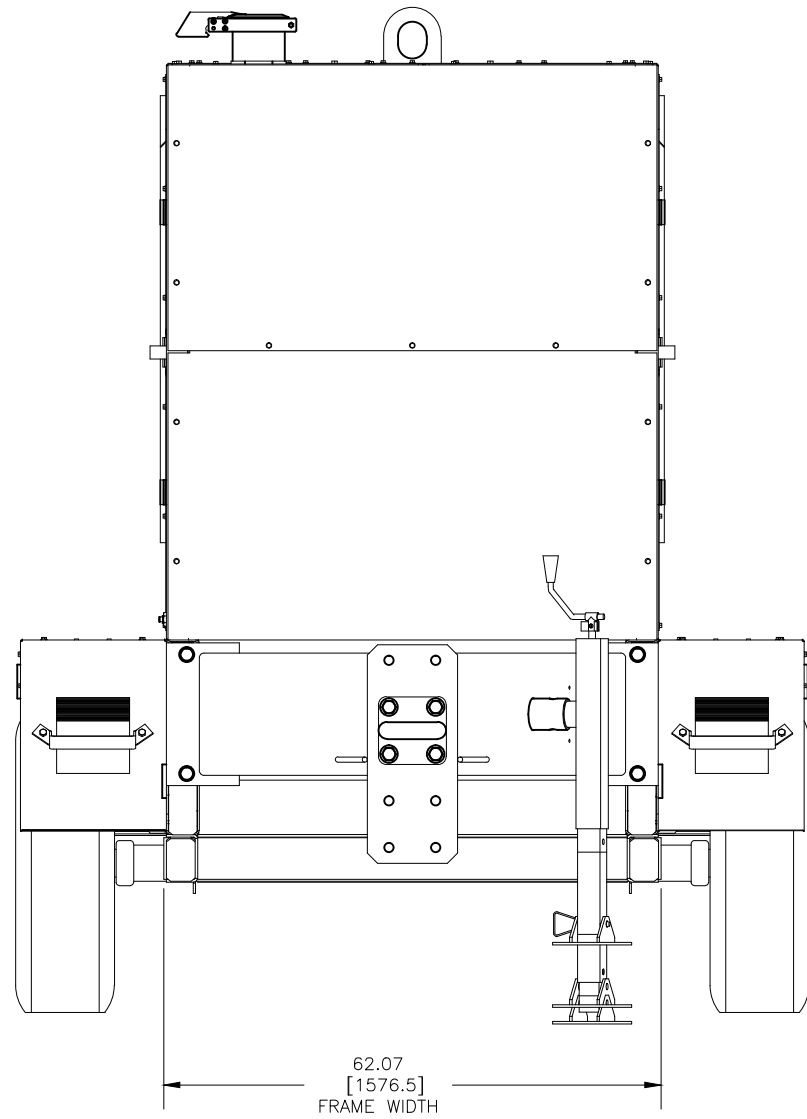

VIEW C

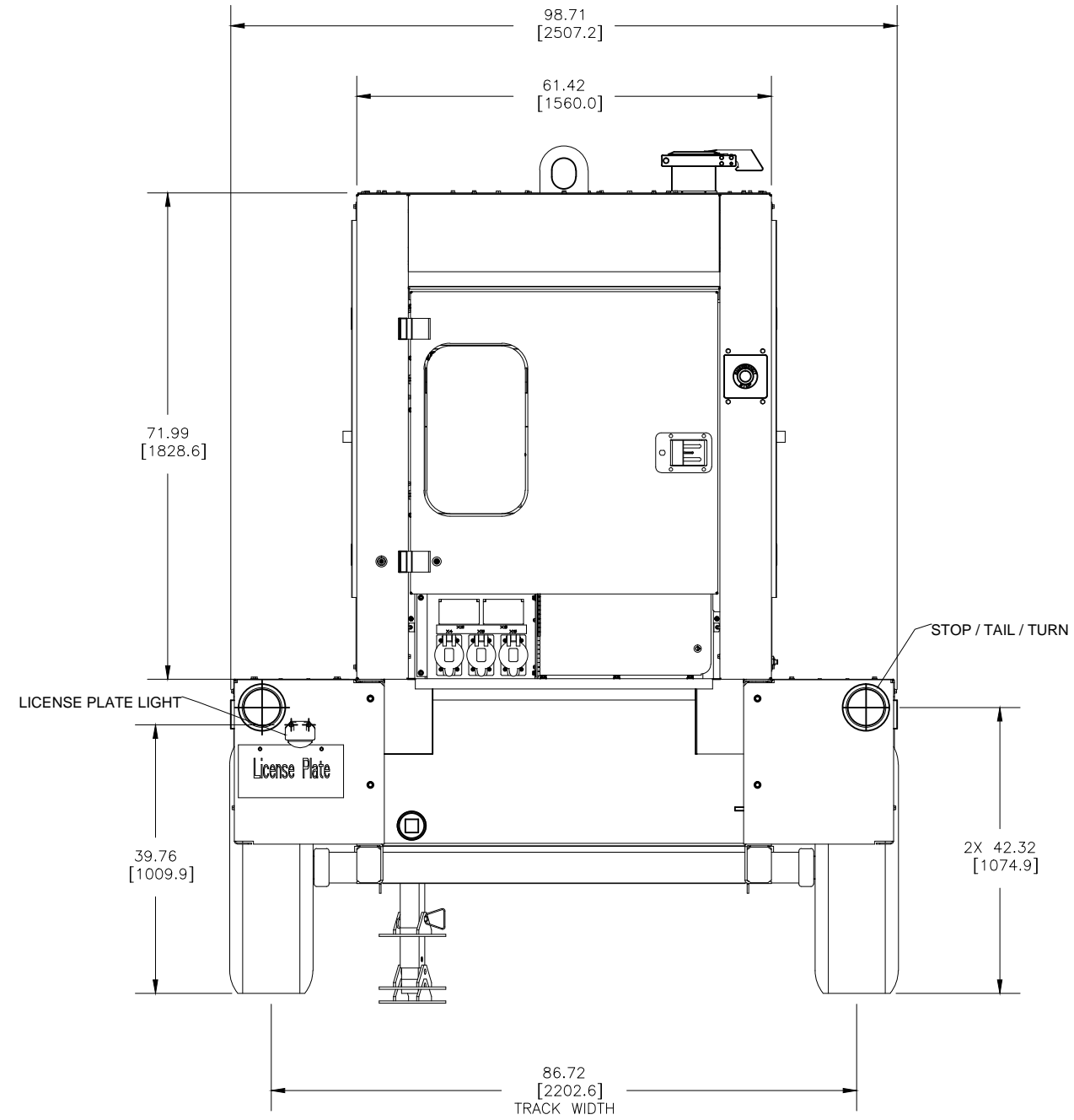

VIEW D

THIS DRAWING AND THE INFORMATION HEREON ARE OUR PROPERTY AND MAY BE USED BY OTHERS ONLY AS AUTHORIZED BY US. UNPUBLISHED-ALL RIGHTS RESERVED UNDER THE COPYRIGHT LAWS.		<input type="checkbox"/> YES <input checked="" type="checkbox"/> NO CONTROLLED DRAWING	
MACHINE TOLERANCES DECIMAL mm inch .X ±1.5 ±0.06 .XX ±0.8 ±0.03 .XXX ±0.3 ±0.01 .XXXX ±0.025 ±0.001 ANGULAR: ±0.5°		DRWN DPOTTER DATE 21NOV14 ENGR AHIGGINS	
FABRICATION TOLERANCES DECIMAL mm inch .X ±3 ±1.2 .XX ±1.5 ±0.08 ANGULAR: ±1.0°		MATERIAL AS NOTED SIMILAR TO --	PART NO. G131739 REV A
		USED ON LAYOUT PART NO. --	UNITS INCH [MM]
		PAGE 4 OF 6	

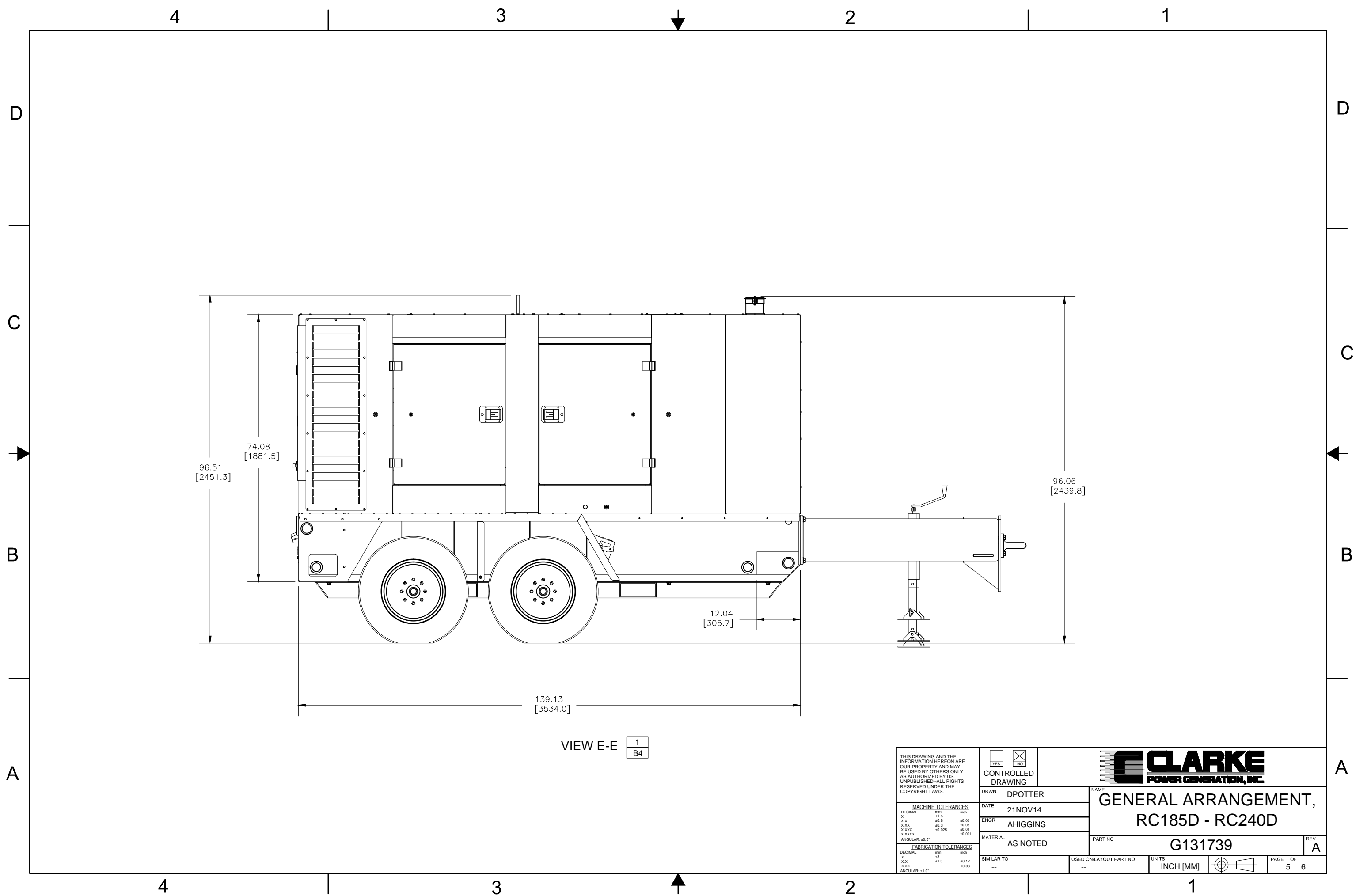

VIEW E-E 1
B4

THIS DRAWING AND THE INFORMATION HEREON ARE OUR PROPERTY AND MAY BE USED BY OTHERS ONLY AS AUTHORIZED BY US. UNPUBLISHED-ALL RIGHTS RESERVED UNDER THE COPYRIGHT LAWS.		<input type="checkbox"/> YES <input checked="" type="checkbox"/> NO CONTROLLED DRAWING	
DRWN DPOTTER		NAME GENERAL ARRANGEMENT, RC185D - RC240D	
DATE 21NOV14		PART NO. G131739	
ENGR AHIGGINS		REV A	
MATERIAL AS NOTED		USED ON LAYOUT PART NO. --	
SIMILAR TO --		UNITS INCH [MM]	PAGE OF 5 6

MACHINE TOLERANCES

DECIMAL	mm	inch
X.	±1.5	±0.06
X.X	±0.8	±0.03
X.XX	±0.3	±0.01
X.XXX	±0.025	±0.001
X.XXXX	±0.01	±0.0005

FABRICATION TOLERANCES

DECIMAL	mm	inch
X.	±3	±0.12
X.X	±1.5	±0.08
X.XX	±1.0	±0.06

ANGULAR: ±0.5°

4 3 2 1

D
C
B
A

D
C
B
A

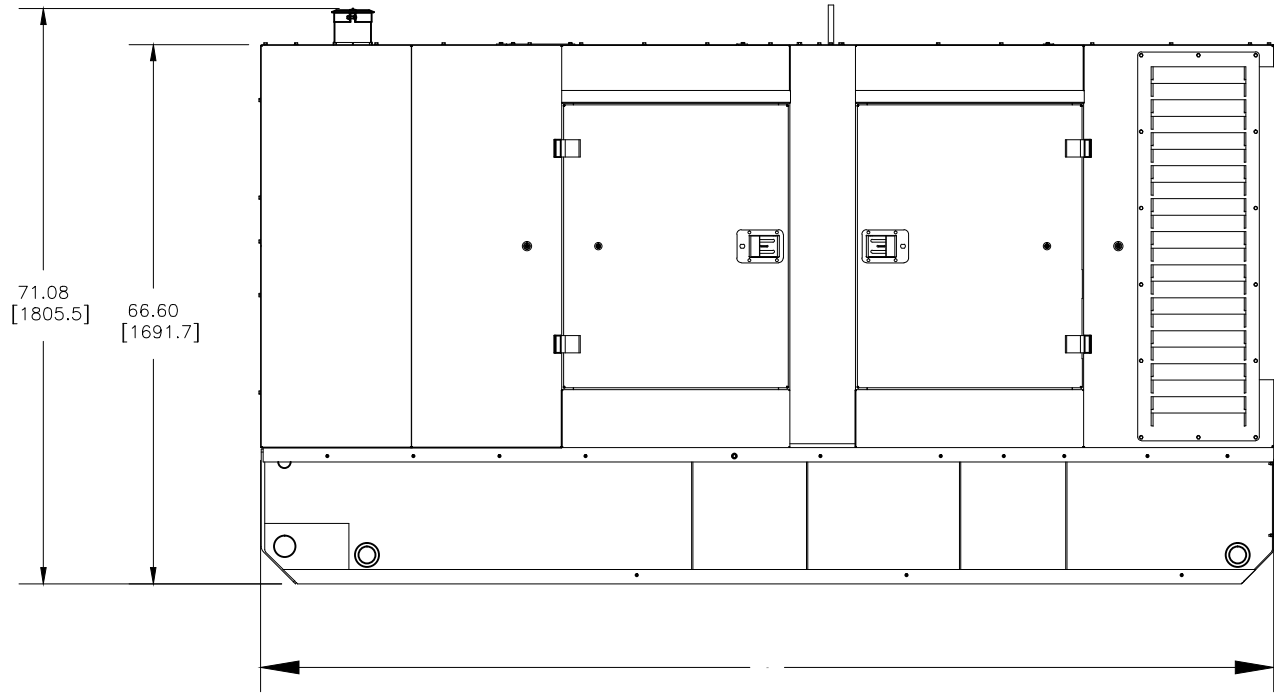

LESS RUNNING GEAR OPTION
(LEFT VIEW)

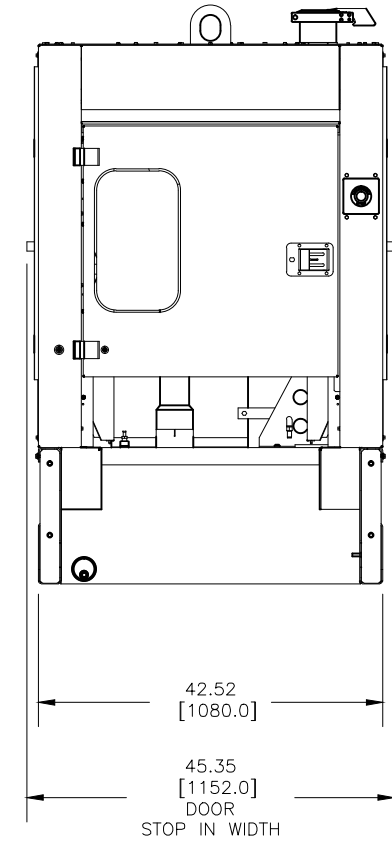

LESS RUNNING GEAR OPTION
(CONTROLS VIEW)

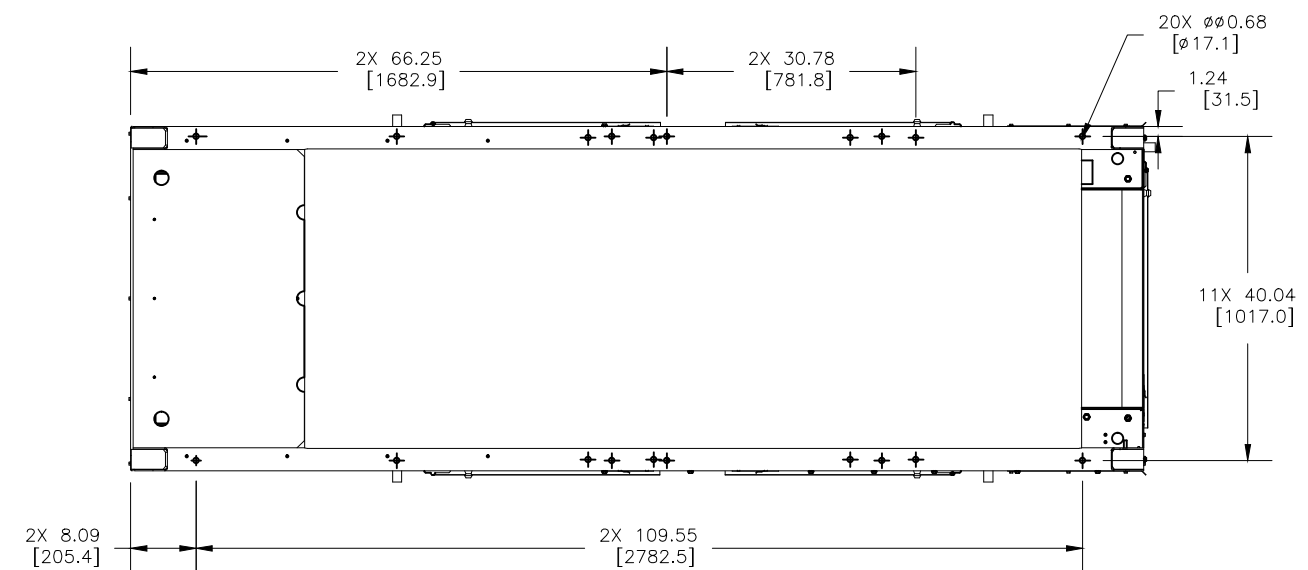

LESS RUNNING GEAR OPTION
(BOTTOM VIEW)

4 3 2 1

THIS DRAWING AND THE INFORMATION HEREON ARE OUR PROPERTY AND MAY BE USED BY OTHERS ONLY AS AUTHORIZED BY US. UNPUBLISHED-ALL RIGHTS RESERVED UNDER THE COPYRIGHT LAWS.		<input type="checkbox"/> YES <input checked="" type="checkbox"/> NO CONTROLLED DRAWING			
MACHINE TOLERANCES DECIMAL mm inch X ±1.5 ±0.06 XX ±0.8 ±0.03 XXX ±0.3 ±0.01 XXXX ±0.025 ±0.001 ANGULAR: ±0.5°		DRWN DPOTTER DATE 21NOV14 ENGR AHIGGINS		NAME GENERAL ARRANGEMENT, RC185D - RC240D	
FABRICATION TOLERANCES DECIMAL mm inch X ±3 ±1.2 XX ±1.5 ±0.08 ANGULAR: ±1.0°		MATERIAL AS NOTED		PART NO. G131739 REV A	
SIMILAR TO --		USED ON LAYOUT PART NO. --		UNITS INCH [MM]	
				PAGE OF 6 6	