



DA7000SSA2

MQ Power Generator

WhisperWatt™

Prime Rating — 6 kW (6 kVA)

Standby Rating — 7 kW (7 kVA)

Single-Phase, 60 Hertz, 1.0 PF

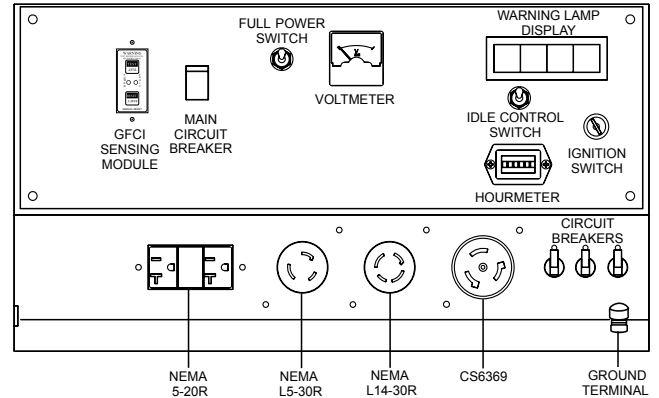
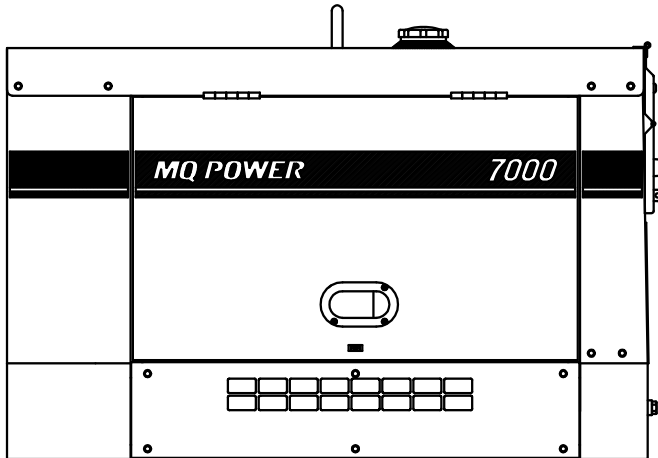

Generator Control Panel

STANDARD FEATURES

- Excellent voltage regulation — Power is controlled within $\pm 2.5\%$ of mean voltage. Self-regulated.
- Main Line Circuit Breaker — Provides full panel GFCI protection, OSHA and NEC compliant, 25 Amp rating.
- Brushless Generator Design — Reduces services and maintenance requirements.
- Sound attenuated, weather resistant, steel housing provides operation at 65 dB(A) at 23 feet. Fully lockable enclosure allows safe unattended operation.
- Internal fuel tank — Holds 6.6 gallons (25 liters).
- Easy Maintenance Design — Quick, direct access to all filters. External fluid drain extensions allow fast, easy service.
- Automatic safety shutdown system — Monitors low oil pressure, high water temperature and battery charge via warning lamp display module.
- Complete generator instrumentation — Includes 2-pole GFCI circuit breaker, AC voltmeter, hour meter, idle control switch, full power switch, warning lamp display, and ignition switch.
- Complete power panel — Fully covered single phase receptacles allow fast and convenient hookup for most applications including temporary power boxes, tools and lighting equipment.
- EPA emissions certified — Tier 4 Final emissions compliant.

OPTIONAL FEATURES

- Automatic Start/Stop Control — Automatically starts and monitors generator during power failure when used in conjunction with a transfer switch.
- Jacket Water Heater — For easy starting in cold climates.
- Solid State Battery Charger — Provides fully automatic and self-adjusting charging to the generator's battery system.
- Fuel/Water Separator — Effectively separates damaging condensation from fuel.
- Emergency Stop Switch — When manually activated, shuts down generator in the event of an emergency.
- Single Wall or Double Wall Sub-base Fuel Tanks — Additional fuel cell for extended run time. Available in a variety of configurations.
- Trailer Mounted Package — Highway legal trailer with electric brakes with single axle configuration. Extra capacity fuel tank is also available.

NOTICE

Generator is not intended for use in enclosed areas or where free flow of air is restricted.

Backfeed to a utility system can cause electrocution, shock and/or property damage. **DO NOT** connect to any building's electrical system except through an approved device.

Specifications are subject to change without notice.



DA7000SSA2

MQ Power Generator

SPECIFICATIONS

| Generator Specifications | |
|--|---|
| Design | Revolving field, self-ventilated drip-proof, single bearing |
| Armature Connection | Series |
| Excitation | Solid State, Statically Excited System |
| Phase | Single Phase (3-wire) |
| Standby Output | 7 KW (7 KVA) |
| Prime Output | 6 KW (6 KVA) |
| Rated Voltage | 120/240V |
| Power Factor | 1.0 |
| Voltage Regulation (No load to full load) | ±2.5% |
| Generator RPM | 3600 |
| Frequency | 60 Hz |
| No. of Poles | 2 |
| No. of Leads | 4 |
| Frequency Regulation: No Load to Full Load | 3-5% under varying loads from no load to 100% rated load |
| Frequency Regulation: Steady State | ±0.25% of mean value for constant loads from no load to full load |
| Insulation | Class F |
| Sound Level dB(A) Full load at 23 feet | 65 |

| Engine Specifications | |
|---------------------------|---|
| Make / Model | Kubota / Z482-E3B |
| Emissions | EPA Tier 4 Final Certified |
| Starting System | Electric |
| Design | Vertical, 4-cycle, liquid cooled, diesel engine |
| Displacement | 29.23 in ³ (479 cc) |
| No. cylinders | 2 |
| Bore x Stroke | 2.52 x 2.68 in. (64 x 68 mm) |
| Gross Engine Power Output | 12.5 hp (9.3 kW) |
| Compression Ratio | 23:1 |
| Engine Speed | 3600 rpm |
| Oil Capacity | .66 gallons (2.5 liters) |
| Coolant Capacity | .74 gallons (2.8 liters) |
| Starting System | Electric |
| Battery | 12V 35Ah x 1 |

| Amperage | |
|---------------|---------------|
| Rated Voltage | Amps |
| 120 Volt | 58.3 Max |
| 120 Volt | 50 Continuous |
| 240 Volt | 29.2 Max |
| 240 Volt | 25 Continuous |

Your MultiQuip dealer is:

| Fuel System | | |
|-------------------------|-------------------------|------------|
| Recommended Fuel | ASTM-D975-No.1 & No.2-D | |
| Fuel Tank Capacity | 6.6 gallons (25 liters) | |
| Fuel Consumption | gph | lph |
| At full load | 0.69 | 2.6 |
| At 3/4 load | 0.55 | 2.1 |
| At 1/2 load | 0.48 | 1.8 |
| At 1/4 load | 0.37 | 1.4 |

| Weights and Measurements | | | | |
|--------------------------|---------------------------|------------------|------------------|--------------------------|
| Housing | A | B | C | D |
| | approx. 34.3 in (870 mm) | 29.1 in (740 mm) | 7.9 in (200 mm) | approx. 6.5 in (165 mm) |
| | E | F | G | H |
| | 44.9 in (1140 mm) | 31.3 in (795 mm) | 28.3 in (720 mm) | 12.8 in (325 mm) |
| Housing | I | J | K | L |
| | approx. 40.4 in (1025 mm) | 23.2 in (590 mm) | 25.6 in (650 mm) | approx. 17.9 in (455 mm) |
| Approx. Dry Weight | 527 lbs (239 kg) | | | |
| Approx. Wet Weight | 582 lbs (264 kg) | | | |

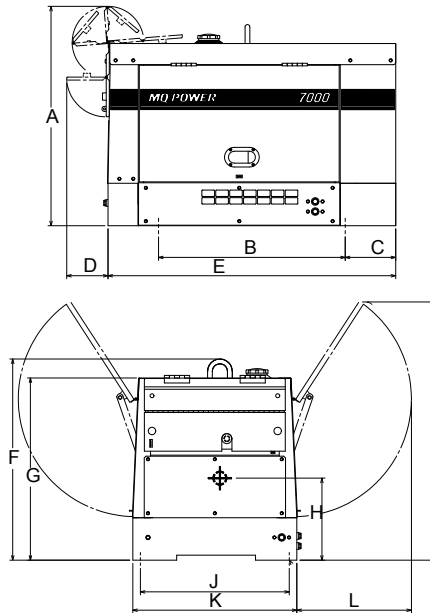

WARRANTY*

Kubota Engine

12 months from date of purchase with unlimited hours or 24 months from date of purchase with 2000 hours (whichever comes first).

Generator

24 months from date of purchase or 2000 hours (whichever occurs first).

Trailer

12 months excluding normal wear items.

*Refer to the express written, one-year limited warranty sheet for additional information.



MULTIQUIP
 POST OFFICE BOX 6254
 CARSON, CA 90749
 310-537-3700 • 800-883-2551
 FAX: 310-604-3831
 E-MAIL: sales@multiquip.com
 WEBSITE: www.multiquip.com