

Operating & Installation Instructions

Manual Transfer Switch

Model Series Covered In This Manual

CH6EGNSYS
 CH10EGNSYS
 CH630EGNSYS
 CH1050EGNSYS

695061
 695062
 695511
 695571

CONTENTS OF PACKAGE

- Manual Transfer Switch NEMA 1 Indoor use only
- Inlet Box NEMA 3R – Rainproof
- 10 ft. power cord
 *8 ft. power cord supplied with 695511 and CH1050EGNSYS

REQUIRED MATERIAL SUPPLIED BY INSTALLER

- See listing on page 6.



Read and follow all Safety Information and Instructions before installation and first use of this product. Keep these instructions for future reference.



Failure to follow instructions could result in serious injury or death. The safety alert symbol is used to identify safety information about hazards which can result in personal injury or death.



WARNING: Engines give off carbon monoxide, an odorless, colorless, poison gas. Do not start or run engine in enclosed area, even if doors or windows are open.

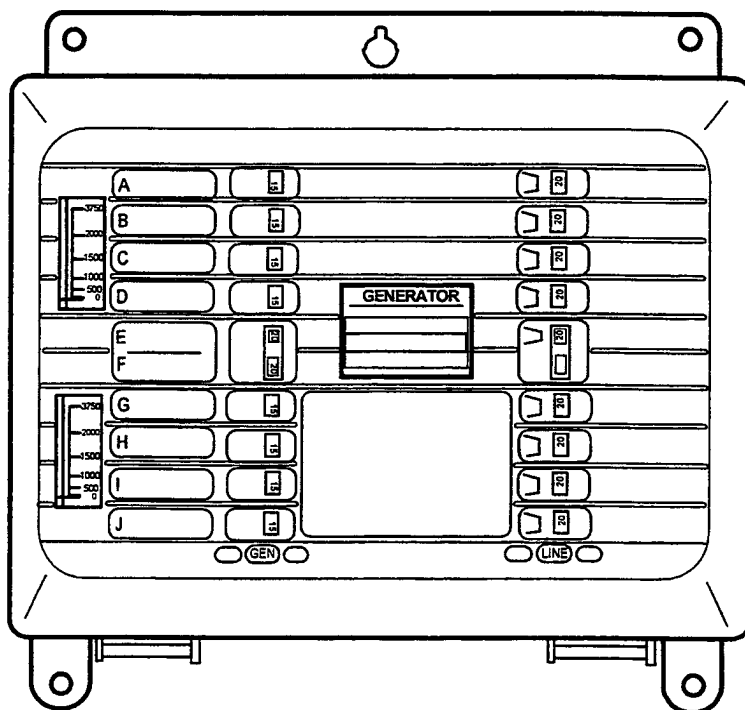

THE OPERATING AND INSTALLATION INSTRUCTIONS CONTAIN SAFETY INFORMATION TO:

- Make you aware of hazards associated with the utility power to generator manual transfer switch
- Inform you of the risk of injury associated with those hazards, and
- Tell you how to avoid or reduce the risk of injury.



SHOCK indicates a hazard which, if not avoided, **could result in death or serious injury.**

- To reduce the risk of electrical shock, the main circuit breaker must be turned OFF while the house load center cover is removed.



WARNING !!

This product must be installed in compliance with local residential wiring and electrical codes by a licensed electrician or qualified professional. Neither Cutler-Hammer nor Briggs & Stratton are responsible for damaged equipment, accidents, or personal injury caused by incorrect installation.

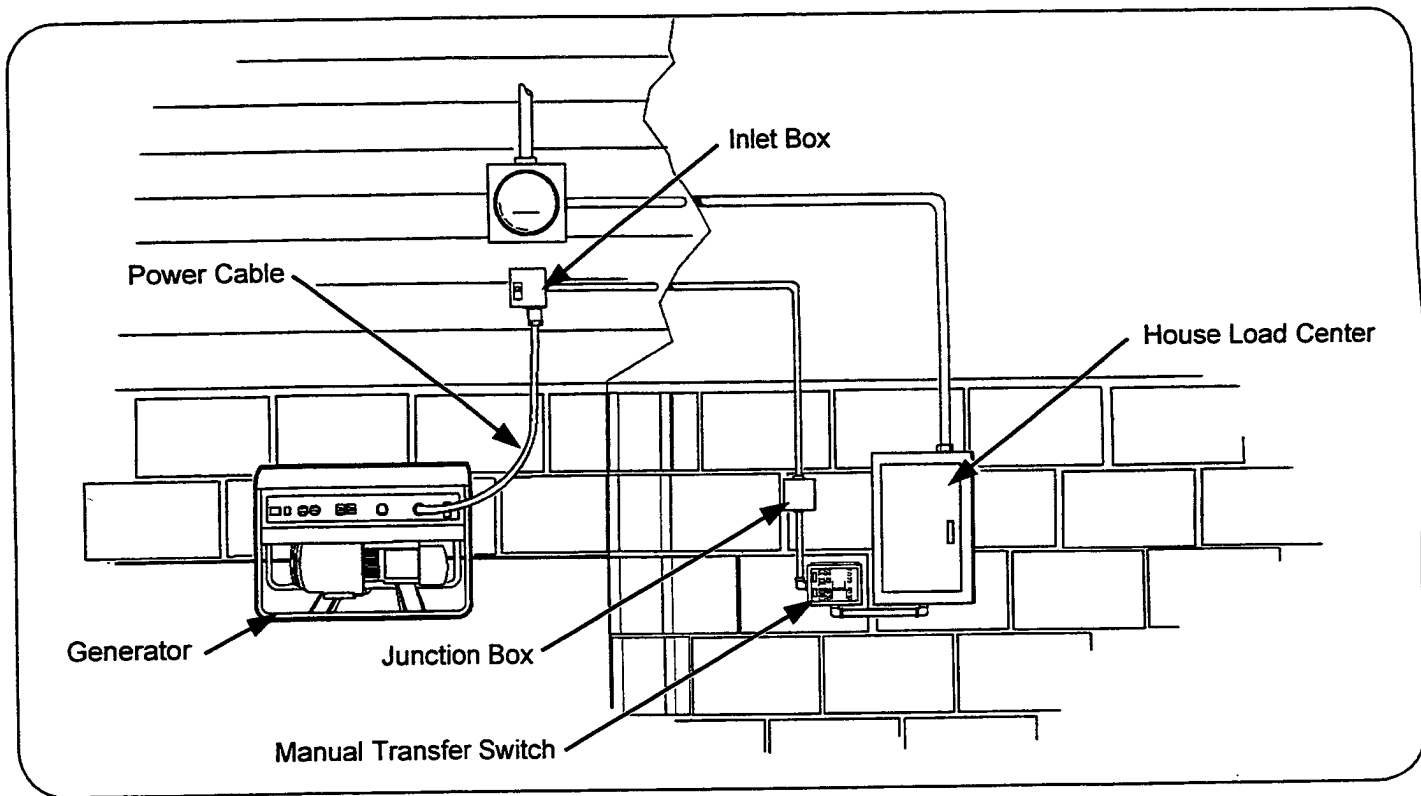

Figure 1. System Component Location

⚠️ WARNING: GENERAL SAFETY INFORMATION

1. A licensed electrician or qualified professional must install the generator manual transfer switch.
 2. During installation, the installer is required to remove the cover panel of the house load center.
- ⚡ To reduce the risk of electrical shock, the main circuit breaker must be turned OFF while the load center cover panel is removed.
3. Always place the manual transfer switch circuit breakers in the OFF position before connecting the generator to the system.
 4. BEFORE starting the generator, plug the power cord from the generator into the inlet box outside the house. BEFORE disconnecting the power cord from the inlet box, shut the generator OFF.

GENERATOR COMPATIBILITY

Only use a generator that is factory equipped with the correct NEMA 4-prong receptacle. DO NOT use a generator equipped with a 3-prong 240V receptacle.

OPERATION

The manual transfer switch is equipped with two sets of circuit breakers ("GEN" and "LINE") and a selection switch. The "GEN" circuit breakers provide power from the generator to the load devices wired to the manual transfer switch. The "LINE" circuit breakers provide utility power from the house load center circuit breakers to the load devices wired to the manual transfer switch.

The selection switch allows the circuit breakers for either the generator power "GEN" or the utility power "LINE" to be turned on to provide power to the selected house loads. The manual transfer switch will not allow utility line power and generator power to be connected to a load device at the same time.

⚠️ **WARNING:** Any device having a test operation that is to be performed by the owner should NOT be tested while both the utility power and generator power are operating at the same time. If a multiwire circuit having a shared neutral wire exists, inadvertent overloading of the neutral wire may occur.

Utility line power being restored while the generator power is being used will not affect the generator. When utility power is restored, follow the *Switch to Utility Power* instructions.

⚠️ **WARNING:** To prevent accidental electrical connection when operating the selection switch, ALL of the manual transfer switch circuit breakers must be placed in the OFF position.

SWITCH TO GENERATOR POWER:

⚠️ **WARNING:** Ensure the generator is outdoors, in proper working condition and connected to the inlet box.

1. Start the generator following procedures provided from the generator manufacturer.
2. Ensure the inlet box circuit breaker is in the ON position. Refer to Figure 1.
3. Place ALL of the utility "LINE" circuit breakers (A) in the OFF position. Refer to Figure 2.

4. Move the selection switch (B) from the utility LINE setting to the GENERATOR setting.

NOTE: This will mechanically prevent the manual transfer switch "LINE" circuit breakers from being placed in the ON position.

5. Place the desired generator "GEN" circuit breakers (C) in the ON position.

IMPORTANT: If there is a delay before switching to generator power during an extended power outage, most or all of the load devices being powered through the manual transfer switch may start at the same time. To avoid possible overload damage to the generator, alternate placing loads on each of the 120 VAC legs of the generator. This is accomplished by turning the generator circuit breakers ON one at a time, alternating between the upper and lower circuit breakers of the manual transfer switch.

Examples:

On the 6 circuit manual transfer switch: Turn on an upper circuit breaker (labeled "A", "B" or "C"), then a lower circuit breaker (labeled "D", "E" or "F"). Continue alternating for remaining circuit breakers.

On the 10 circuit manual transfer switch: Turn on an upper circuit breaker (labeled "A" through "E"), then a lower circuit breaker (labeled "F" through "J"). Continue alternating for remaining circuit breakers.

CAUTION: Watch the watt meters (D) to ensure that the loads do not exceed the rated output of the generator. Maintain balanced loads where each of the watt meters stay at approximately the same level.

Most portable generators do not have the capacity to handle all of the loads that have been wired through the manual transfer switch at the same time.

Alternate device loads such as a refrigerator and furnace to avoid exceeding the power output of the generator.

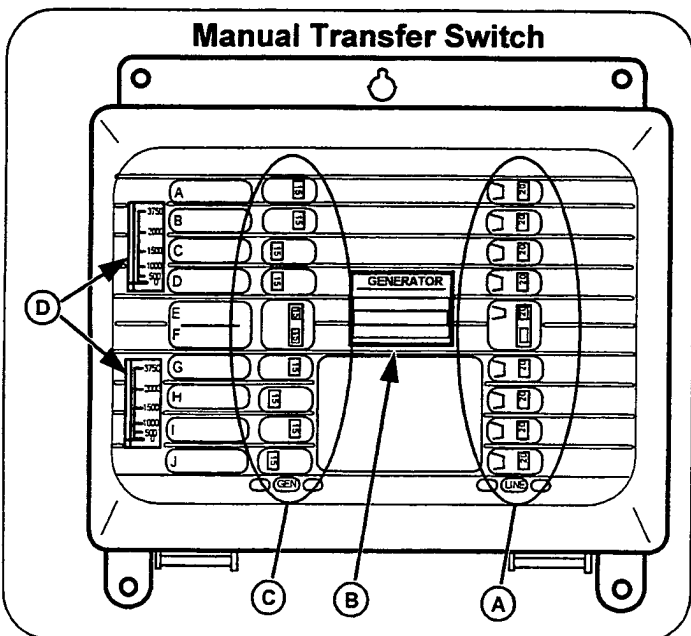

Figure 2. Manual Transfer Switch Controls (10 Circuit Model Shown)

SWITCH TO UTILITY POWER:

1. Place the manual transfer switch "GEN" circuit breaker (C) in the OFF position.
2. Move the selection switch (B) from the GENERATOR setting to the utility LINE setting.
3. Place all of the manual transfer switch "LINE" circuit breakers (A) in the ON position.
4. Shut off the generator and disconnect the power cord to the inlet box.

Testing:

Periodically switch from normal utility power to generator power following the procedures above. This will help familiarize the operator with the switching procedures and verify that the manual transfer switch is operating properly. Testing will also verify that the devices listed on the labels are still connected through the listed circuits.

INSTALLATION PROCEDURE

Before Installation:

CAUTION: Determine the load draw requirements of devices that will be operated through the manual transfer switch. Loads can be determined using a clamp-on ammeter to measure actual loads; determined from data plates on each appliance; or, estimated from the reference guide below.

Balance loads between the two 120 VAC legs of the manual transfer switch. Refer to schematics.

IMPORTANT: NO load placed through a circuit in the manual transfer switch should exceed the rating of that circuit breaker.

NOTE: Some electric motors require more than two times more power for starting than operating. This initial draw only lasts for a few seconds. Allow for the high starting load draw in determining load requirements. The load draws given in the reference guide are approximate load draws for typical appliances. Refer to the data plates or service literature of appliances for specific information of that appliance.

REFERENCE GUIDE

LOAD DEVICE	APPROXIMATE LOAD DRAW
Range Burner (one)	1500W – 6.25A @ 240V
Electric Blanket	1200W – 10A @ 120V
Electric Fry Pan	1500W – 12.5A @ 120V
Freezer	800W – 6.7A @ 120V
Furnace Blower (1/3 HP)	800W – 6.7A @ 120V (1500W – 12.5A starting)
Light Bulb (75 W)	75W – 0.63A @ 120V (for each bulb)
Light Bulb (100 W)	100W – 0.85A @ 120V (for each bulb)
Microwave	750W – 6.25A @ 120V
Radio	50W-200W – 0.5A - 1.7A @ 120V
Refrigerator	800W – 6.7A @ 120V
Sump Pump (1/2 HP)	1000W – 8.3A @ 120V (2200W – 18.3A starting)
Television	100W-500W – 0.85A - 4.2A @ 120V
Well Pump (Shallow)	1000W – 8.3A @ 120V (2200W – 18.3A starting)
Well Pump (Deep)	2000W – 8.3A @ 240V (4000W – 16.7A starting)
Non-Listed Device Load	Determine the wattage or amp draw of the device. Use the formula: Watts = Volts X Amps.

Manual Transfer Switch Installation:

1. Ensure that there is a proper space next to the house load center to properly mount the manual transfer switch. The manual transfer switch can be mounted either to the right or to the left of the load center. Refer to Figure 3.

IMPORTANT: After locating the place to mount the manual transfer switch, rotate the flexible conduit connector (A) on the bottom of the manual transfer switch to either the left or right. The connector rotates past the rear edge of the manual transfer switch box and cannot be rotated properly after the manual transfer switch is mounted to the wall. To avoid damage to the wires in the flexible conduit, *Do not rotate more than 180°.*

NOTE: The flexible conduit connector is designed to rotate on the manual transfer switch box without opening the box. After installation the conduit connector will remain loose.

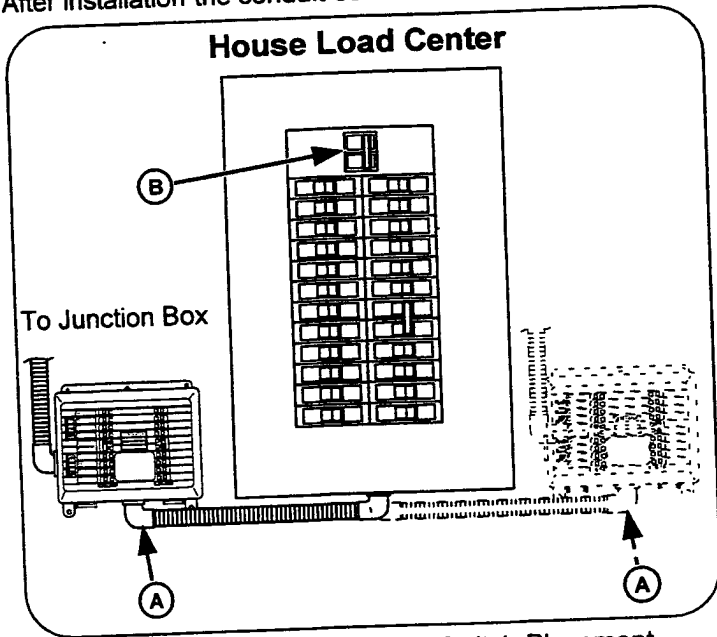

Figure 3. Manual Transfer Switch Placement

2. Secure the manual transfer switch to the wall.
3. Place the load center main circuit breaker (B) in the OFF position.
4. Locate an appropriate 1" knockout on the load center.

DANGER !!

Wires on the utility line side of the main circuit breakers remain electrically "hot". Contact with these wires must be avoided as dangerous or fatal electrical shock will occur.

5. Remove the knockout previously located on the load center. Feed all wires from the manual transfer switch conduit through the knockout hole. Secure the flexible conduit end connector to the load center.
6. Install the ground (Grn) wire into the load center ground terminal strip. Refer to Figure 7.
7. Install the neutral lead (Wht) into the load center neutral terminal strip.

NOTE: Figure 7 shows a typical house load center. The neutral and ground terminal strips may be separate, tied together, or there may be only one terminal strip. Follow local

and national electrical codes when installing and securing the neutral and ground wires from the manual transfer switch.

Junction Box and Inlet Box Installation:

1. Route the flexible conduit on the left side of the manual transfer switch to the desired location to mount a junction box. Refer to Figure 4.
2. Mount a junction box to the wall.
3. Feed the four wires from the manual transfer switch through a knockout in the junction box and secure the flexible conduit connector to the junction box.

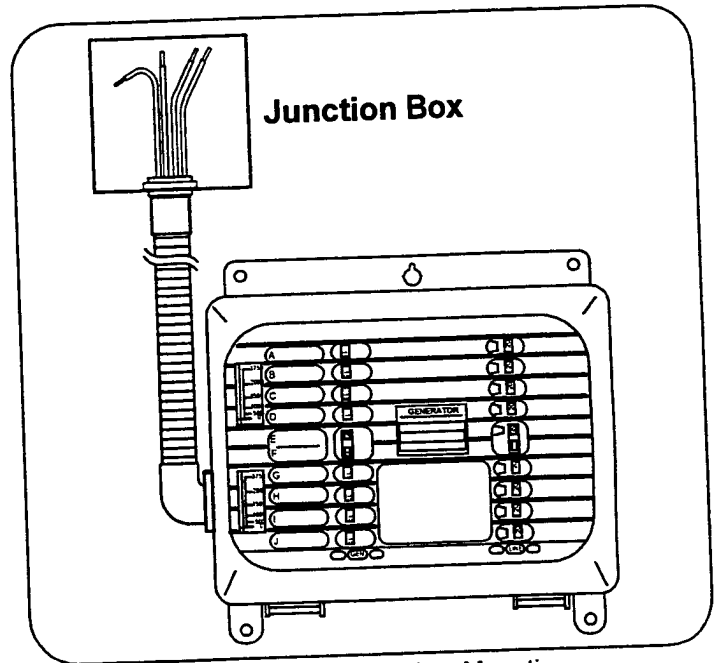

Figure 4. Junction Box Mounting

4. Carefully plan a route from the junction box to the outdoor location where the inlet box will be installed.

NOTE: The conduit may be connected to the inlet box through the back or either side. Determine where the conduit will be connected before routing conduit.

5. Install a (3/4") conduit from the junction box to the desired location for the inlet box.
6. Remove the front cover of the inlet box and remove the two (2) screws securing the inside panel assembly.

NOTE: The circuit breaker and receptacle are secured to the inside cover. Do not remove them from the cover.

7. Mount the inlet box on the outside wall of the house.



ATTENTION: Important Mounting Instructions!

The 50 amp inlet box must be mounted a minimum of 30 inches above the horizontal surface adjacent to the mounting wall.

8. Secure the conduit from the junction box to the inlet box in a manner that meets all local and national code requirements and maintains the weather resistant integrity of the inlet box. Use only U.L. listed rain tight or liquid tight conduit hubs. Install hubs and conduit according to the hub manufacturer's instructions.
9. Run four electrical wires from the inlet box to the junction box. Check local and national electrical codes to determine proper wire gauge.

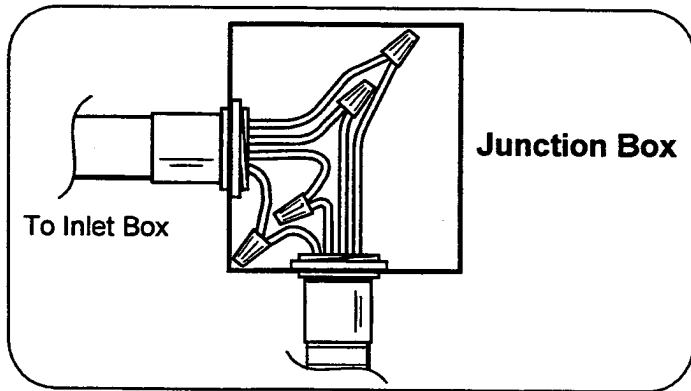

Figure 5. Junction Box Wiring (Typical)

10. Connect and secure the wires inside of the junction box. Refer to Figure 5.

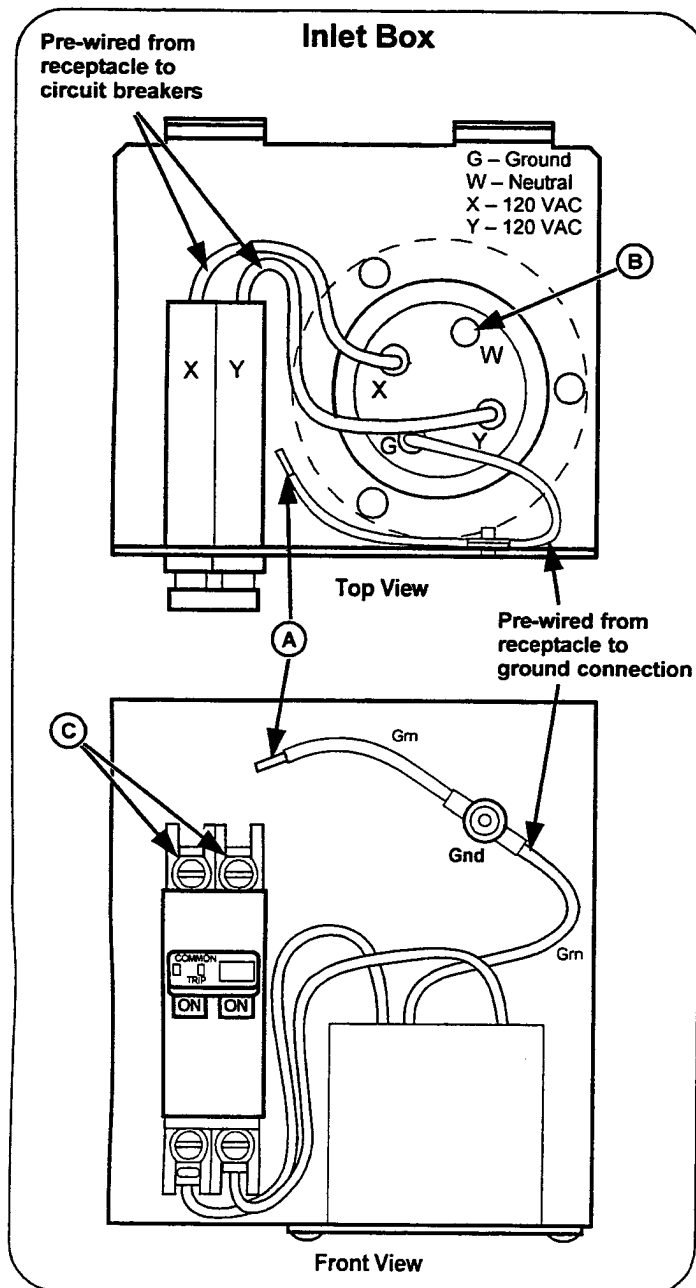

Figure 6. Inlet Box Wiring (Prewired)

11. Connect the ground wire from the junction box to the Green ground wire (A) in the inlet box (secured to the front panel of the inlet box) with an appropriate wire terminal. Refer to Figure 6.
12. Connect the neutral wire to the open receptacle "W" terminal (B) in the inlet box.
13. Connect the two load wires from the junction box to the circuit breakers (C) in the inlet box.
14. Install the inlet box inner panel and secure with the screw removed earlier.

Wiring 120 Volt Circuits:

1. Determine the power circuit in the load center that will be connected to the "A" circuit breaker in the manual transfer switch.

CAUTION: When selecting circuits to wire through the manual transfer switch, DO NOT select circuits wired through a GFCI in the load center. Wiring a GFCI through the manual transfer switch will disable the GFCI when generator power is being used.



WARNING: Ensure that any selected circuits that are part of a multiwire branch circuits are wired on opposing legs (phases) to prevent inadvertent overload of the neutral wire.

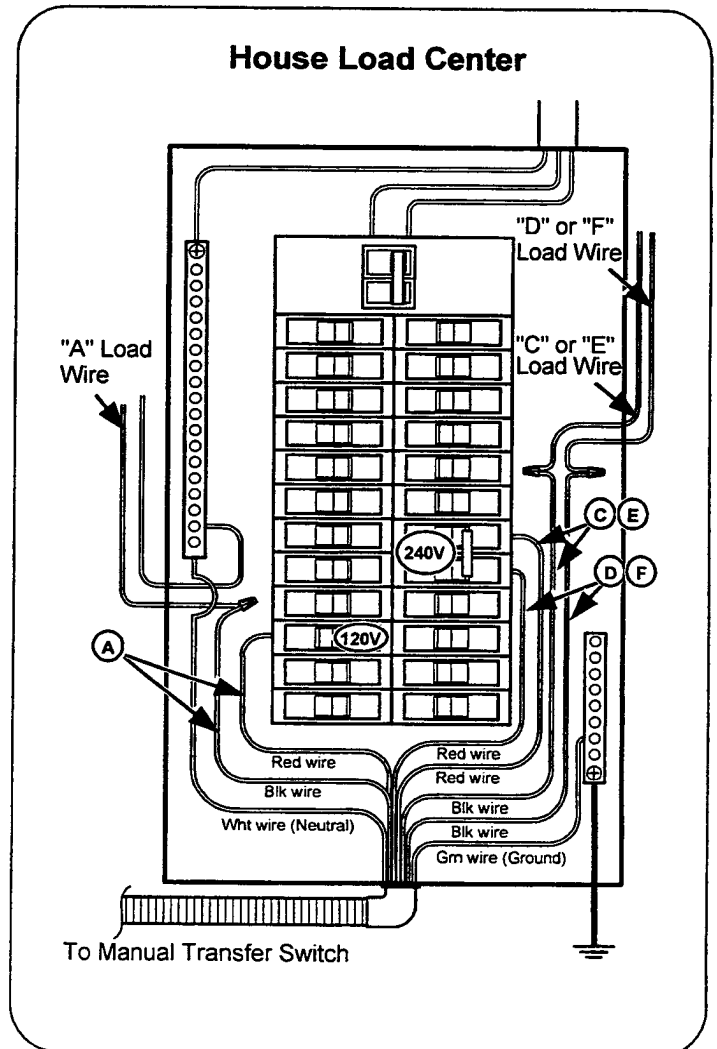

Figure 7. Load Center Wiring (Typical)

2. Place the load center circuit breaker for that circuit to the OFF position. Disconnect the "A" load wire from that circuit breaker. Refer to Figure 7.
3. Locate the labeled "A" Black and "A" Red wires from the manual transfer switch. Route those wires to the selected circuit breaker. Trim and strip the "A" wires to an appropriate length.
4. Connect the wire ("A" load wire) disconnected in step 2 to the "A" Black wire with an appropriate wire connector.
5. Connect the "A" Red wire from the manual transfer switch to the selected circuit breaker in the load center.
6. Determine the power circuit that will be connected to "B" circuit breaker in the manual transfer switch.
7. Follow steps 2 through 5 for the "B" circuit. Repeat with all other selected 120 VAC circuits.



CAUTION: When connecting house circuits to the 20A Generator side circuits ("C&D" on the 6 circuit system; "D," "E&F" and "G" on the 10 circuit, 50A system), care should be taken to not connect these Transfer Switch circuits into 15 Amp house circuits.

SPECIFICATIONS

Model	CH6EGNSYS 695061	CH10EGNSYS 695062
Max. Load per circuit (generator/line)	15-20/20A	15-20/20A
Max. Load - Watts (generator)	4800W	7200W
Max. Load - Amps (generator)	40A	60A
Number of 1 Pole Circuits (120 VAC)	4	8
Number of 2 Pole Circuits (120/240 VAC)	1	1

Wiring 240 Volt Circuit:

NOTE: The ganged 240V circuit breaker may be used as two individual 120V circuit breakers. However, if one of the 120V circuit line loads "trips" a circuit breaker, both of the ganged circuit breakers will "trip".

1. Turn the load center 240V circuit breakers (two ganged 120V circuit breakers typically) for the selected circuit to the OFF position. Disconnect the house load wires from the circuit breakers. Refer to Figure 7.

For 6 circuit manual transfer switch:

2. Locate the "C" and "D" Black and "C" and "D" Red wires from the manual transfer switch. Route the two "C" and two "D" wires to the circuit breakers for the selected 240V circuit. Refer to Figure 7.
3. Trim and strip each of the two "C" and two "D" wires to an appropriate length.
4. Connect and secure the disconnected house load wires to the "C" and "D" Black wires from the manual transfer switch with appropriate wire connectors.
5. Connect the "C" and "D" Red wires from the manual transfer switch to the selected circuit breakers in the load center.

For 10 circuit manual transfer switch:

2. Locate the "E" and "F" Black and "E" and "F" Red wires from the manual transfer switch. Route the two "E" and two "F" wires to the circuit breakers for the selected 240V circuit. Refer to Figure 7.
3. Trim and strip each of the two "E" and two "F" wires to an appropriate length.
4. Connect and secure the disconnected house load wires to the "E" and "F" Black wires from the manual transfer switch with appropriate wire connectors.
5. Connect the "E" and "F" Red wires from the manual transfer switch to the selected circuit breakers in the load center.
6. Install and secure the house load center cover.
7. Label all circuits on the front of the manual transfer switch with the name (function) of the connected load device.

Model	CH630EGNSYS 695571	CH1050EGNSYS 695511
Max. Load per circuit (generator/line)	15-20/20A	15-20/20A
Max. Load - Watts (generator)	7200W	12,000W
Max. Load - Amps (generator)	60A	100A
Number of 1 Pole Circuits (120 VAC)	4	8
Number of 2 Pole Circuits (120/240 VAC)	1	1

REQUIRED MATERIAL SUPPLIED BY INSTALLER

- Junction Box
- Conduit (Inlet box to junction box)
- Conduit Connectors (Conduit from inlet box to junction box)
- Electrical Wire (Inlet box to junction box)
- Wire Nuts
- Screws and anchoring items used to secure the manual transfer switch, junction box and inlet box

TROUBLESHOOTING

Problem	Possible Cause	Possible Solution
Generator slows down when loads are connected.	1. Generator is overloaded	1. Check watt meters to determine possible overloads. Turn circuit breakers OFF to balance or reduce loads.
Generator runs but no power to load devices.	1. Inlet box circuit breakers are not in the ON position. 2. Manual transfer switch selector is in incorrect position and/or circuit breakers are in incorrect position. 3. Poor or no connection between generator and inlet box. 4. Generator circuit breaker(s) "tripped."	1. Check and reset circuit breakers in inlet box. 2. Check manual transfer switch for correct selection switch position ("GEN") and/or turn circuit breakers ON. 3. Check power cord and connections between generator and inlet box. 4. Reset generator circuit breaker(s).
Only some load devices work on generator power.	1. Manual transfer switch circuit breaker(s) are OFF 2. Load devices are not plugged into connected circuit outlets.	1. Check circuit breakers. 2. Verify that load devices are plugged into correct outlets.
Unable to turn manual transfer switch circuit breakers ON.	1. Selection switch is in incorrect position.	1. Verify selection switch is placed in proper position. Set circuit breakers.
240V manual transfer switch circuit breaker trips.	1. One or both of the 120V lines is overloaded or shorted to ground.	1. Determine which line(s) is overloaded or shorted. Disconnect load or correct short. NOTE: If one of the 120V load circuits trips the circuit breaker, both of the tied circuit breakers will trip.
No power to the load device when the manual transfer switch selector is in "LINE" operation (generator OFF and not being used).	1. The house load center circuit breaker or the manual transfer switch circuit breaker for that load device is tripped.	1. Check both the house load center circuit breaker and the manual transfer switch circuit breaker that the load device is powered through.

Limited Warranty

Cutler-Hammer Inc. warrants that the Cutler-Hammer/Briggs & Stratton Manual Power Transfer Switches (CH6EGNSYS/695061, CH10EGNSYS/695062, CH630EGNSYS/695571 and CH1050EGNSYS/695511) and power inlet boxes, and power cords and flange kits (695520, 695521, 695522, 695523, 695649, CH6EGENCORD, CH6EGEN10CORD, CH6EGEN25CORD, CH10EGEN25CORD, 695514, 695066, 695067, CHEGENFKIT, CH6EGENPIB and CH10EGENPIB) will be free from failure due to defects in workmanship and material for a period of 5 years from date of purchase by the original retail purchaser under normal care and proper usage in a residential installation.

In the event the product fails to comply with this warranty Cutler-Hammer Inc. will, at its option, repair or replace the defective product, or component(s) or part(s) thereof. To obtain warranty service the original retail purchaser should return the product to the place of purchase or deliver the product prepaid to Cutler-Hammer Inc. at the address set forth below. Proof of purchase in the form of a receipt or invoice which is evidence that the unit is within the warranty period must be presented to obtain warranty service.

Notice requirements and limitations applicable to Cutler-Hammer Inc. warranties are:

- A. This warranty does not cover failure or damage due to improper storage, installation, operation, maintenance, alteration, repair, accident, misuse, abuse or negligence. This warranty does not cover reimbursement for labor, transportation, gaining access, removal, installation, temporary power, or any other expenses which may be incurred in connection with repair or replacement.
- B. REPAIR OR REPLACEMENT AS PROVIDED UNDER THIS WARRANTY IS THE EXCLUSIVE REMEDY OF THE PURCHASER AND THE LIMIT OF THE LIABILITY OF CUTLER-HAMMER INC. WITH RESPECT TO THIS PRODUCT, WHETHER IN CONTRACT, IN TORT (INCLUDING NEGLIGENCE OR STRICT LIABILITY) OR OTHERWISE. CUTLER-HAMMER INC. DISCLAIMS ALL OTHER WARRANTIES, INCLUDING WITHOUT LIMITATION, ANY IMPLIED WARRANTY OF MERCHANTABILITY OR FITNESS FOR A PARTICULAR PURPOSE. IN NO EVENT WILL CUTLER-HAMMER INC. BE LIABLE FOR ANY OTHER DAMAGES, WHETHER DIRECT, INCIDENTAL, CONSEQUENTIAL OR OTHERWISE.
- C. With respect to products purchased by consumers of the United States for personal use, the implied warranties, including but not limited to the warranties of merchantability and of fitness for a particular purpose, are not excluded but are limited to the duration of the applicable warranty period. Some states do not allow limitations on the duration of an implied warranty, so the above limitation may not apply to buyer. Similarly, some states do not allow the exclusion or limitation of incidental or consequential damages, so the above excision or limitation may not apply to buyer. This warranty gives buyer specific legal rights, and buyer may also have other rights which may vary from state to state.

This warranty covers residential use of Cutler-Hammer/Briggs & Stratton Manual Power Transfer Switches and excludes any commercial applications.

CUTLER-HAMMER INC.
1000 CHERRINGTON PARKWAY
MOON TOWNSHIP, PENNSYLVANIA 15108

www.briggsandstratton.com

1-800-356-1243

www.ch.cutler-hammer.com

SCHEMATICS

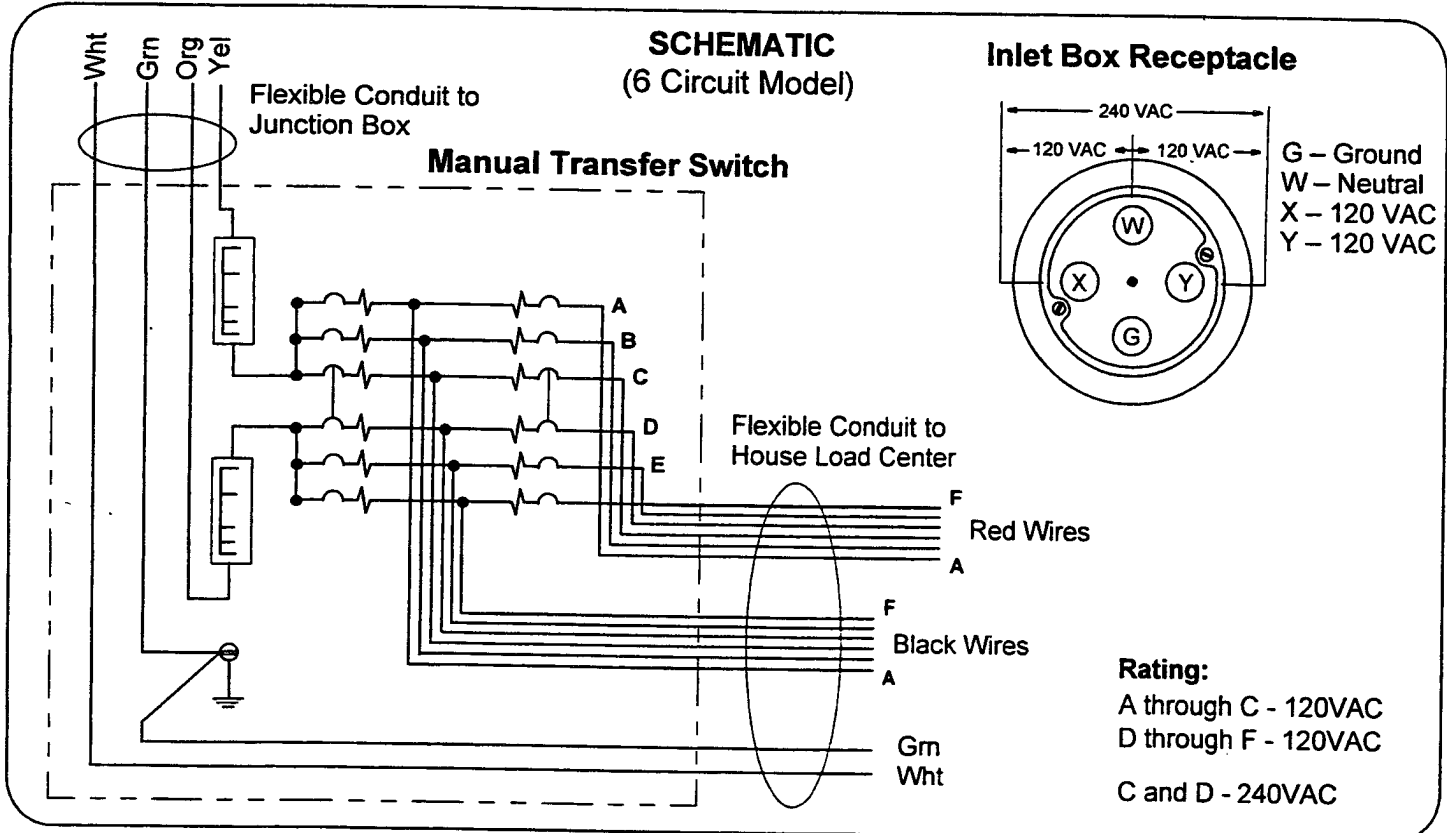

Figure 9. Schematic, 6 Circuit Model

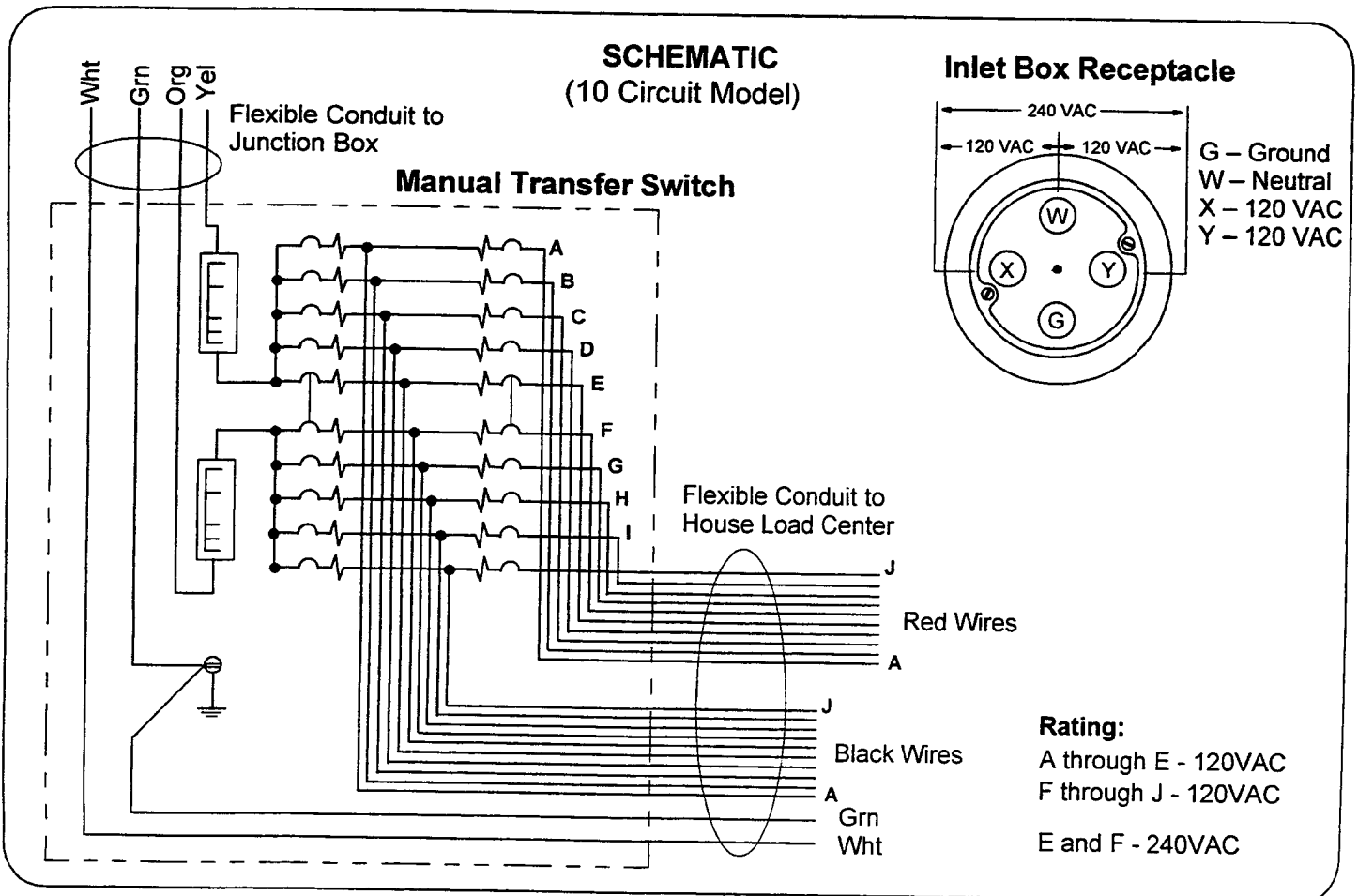

Figure 10. Schematic, 10 Circuit Model