

# Instruction Manual

## Nexus Remote Monitor



# Table of Contents

## TABLE OF CONTENTS

SAFETY.....	Inside Front Cover
Read This Manual Thoroughly.....	1
Safety Rules .....	1
Operation and Maintenance.....	2
How to Obtain Service .....	3
INTRODUCTION .....	3
BATTERY INSTALLATION.....	3
NEXUS WIRELESS MONITOR OPERATION.....	3
Green LED (Generator OK) .....	3
Yellow LED (Maintenance Needed) .....	3
Red LED (Contact Dealer) .....	3
Pair/Reset Button.....	4
INSTALLATION .....	4
Generator Side Transceiver Installation Instructions .....	4
Display Unit Startup.....	6
Re-assemble the Generator.....	7
Display Unit Mounting.....	7
ADDING A SECOND DISPLAY UNIT TO THE SYSTEM .....	8
APPENDIX.....	8
Retrofitting the Nexus Remote Monitor into a Pre-2010 Model Generator.....	8
FINAL ASSEMBLY DECAL DRAWING .....	9
WARRANTY .....	Back Cover

## SAFETY

### Compliance Statement (Part 15.19)

This device complies with Part 15 of the FCC Rules.

Operation is subject to the following two conditions:

1. This device may not cause harmful interference, and
2. This device must accept any interference received, including interference that may cause undesired operation.

### Warning (Part 15.21)

Changes or modifications not expressly approved by the party responsible for compliance could void the user's authority to operate the equipment.

### FCC Interference Statement (Part 15.105 (b))

This equipment has been tested and found to comply with the limits for a Class B digital device, pursuant to Part 15 of the FCC Rules. These limits are designed to provide reasonable protection against harmful interference in a residential installation. This equipment generates uses and can radiate radio frequency energy and, if not installed and used in accordance with the instructions, may cause harmful interference to radio communications. However, there is no guarantee that interference will not occur in a particular installation. If this equipment does cause harmful interference to radio or television reception, which can be determined by turning the equipment off and on, the user is encouraged to try to correct the interference by one of the following measures:

- Reorient or relocate the receiving antenna.
- Increase the separation between the equipment and receiver.
- Connect the equipment into an outlet on a circuit different from that to which the receiver is connected.
- Consult the dealer or an experienced radio/TV technician for help.

This portable transmitter with its antenna complies with FCC/IC RF exposure limits for general population / uncontrolled exposure.

### Section 7.1.5 of RSS-GEN

Operation is subject to the following two conditions:

1. This device may not cause interference, and
2. This device must accept any interference, including interference that may cause undesired operation of the device.

To comply with FCC/IC RF exposure limits for general population / uncontrolled exposure, the antenna(s) used for this transmitter must be installed to provide a separation distance of at least 20 cm from all persons and must not be co-located or operating in conjunction with any other antenna or transmitter.

 **SAVE THESE INSTRUCTIONS** – This manual is in addition to the Owner's Manual for the generator. All warnings and recommendations in the manufacturer's manuals must be strictly adhered to for safe use.

 **SAVE THESE INSTRUCTIONS** – The manufacturer suggests that these rules for safe operation be copied and posted in potential hazard areas. Safety should be stressed to all operators, potential operators, and service and repair technicians for this equipment.

 **SAVE THESE INSTRUCTIONS** – This manual contains important instructions that should be followed during installation and maintenance of the generator and batteries.

## READ THIS MANUAL THOROUGHLY

If any portion of this manual is not understood, contact the nearest Authorized Service Dealer for starting, operating and servicing procedures.

Throughout this publication, and on tags and decals affixed to the generator, DANGER, WARNING, CAUTION and NOTE blocks are used to alert personnel to special instructions about a particular service or operation that may be hazardous if performed incorrectly or carelessly. Observe them carefully. Their definitions are as follows:

### **DANGER!**

INDICATES A HAZARDOUS SITUATION OR ACTION WHICH, IF NOT AVOIDED, WILL RESULT IN DEATH OR SERIOUS INJURY.

### **WARNING!**

Indicates a hazardous situation or action which, if not avoided, could result in death or serious injury.

### **CAUTION!**

Indicates a hazardous situation or action which, if not avoided, could result in minor or moderate injury.

### NOTE:

Notes contain additional information important to a procedure and will be found within the regular text body of this manual.

These safety warnings cannot eliminate the hazards that they indicate. Common sense and strict compliance with the special instructions while performing the action or service are essential to preventing accidents.

Four commonly used safety symbols accompany the **DANGER**, **WARNING** and **CAUTION** blocks. The type of information each indicates is as follows:

 This symbol points out important safety information that, if not followed, could endanger personal safety and/or property of others.

 This symbol points out potential explosion hazard.

 This symbol points out potential fire hazard.

 This symbol points out potential electrical shock hazard.

## SAFETY RULES

Study these SAFETY RULES carefully before installing, operating or servicing this equipment. Become familiar with this *Owner's Manual* and with the unit. The generator can operate safely, efficiently and reliably only if it is properly installed, operated and maintained. Many accidents are caused by failing to follow simple and fundamental rules or precautions.

The manufacturer cannot anticipate every possible circumstance that might involve a hazard. The warnings in this manual, and on tags and decals affixed to the unit are, therefore, not all-inclusive. If using a procedure, work method or operating technique the manufacturer does not specifically recommend, ensure that it is safe for others. Also make sure the procedure, work method or operating technique utilized does not render the generator unsafe.

### **DANGER!**

 Despite the safe design of this unit, operating this equipment imprudently, neglecting its maintenance or being careless can cause possible injury or death. Permit only responsible and capable persons to operate or maintain this equipment.

 Potentially lethal voltages are generated by these machines. Ensure all steps are taken to render the machine safe before attempting to work on the generator.

 Parts of the generator are rotating and/or hot during operation. Exercise care near running generators.

### **CALIFORNIA PROPOSITION 65 WARNING**

Engine exhaust and some of its constituents are known to the State of California to cause cancer, birth defects and other reproductive harm.

### **CALIFORNIA PROPOSITION 65 WARNING**

This product contains or emits chemicals known to the State of California to cause cancer, birth defects and other reproductive harm.

# Safety Rules

## **GENERAL HAZARDS**

- For safety reasons, the manufacturer recommends that the installation, initial start-up and maintenance of this equipment is carried out by a Dealer.
- The engine exhaust fumes contain carbon monoxide, which can be DEADLY. This dangerous gas, if breathed in sufficient concentrations, can cause unconsciousness or even death. Do NOT alter or add to the exhaust system or do anything that might render the system unsafe or in noncompliance with applicable codes and standards.
- Keep hands, feet, clothing, etc., away from drive belts, fans, and other moving or hot parts. Never remove any drive belt or fan guard while the unit is operating.
- Adequate, unobstructed flow of cooling and ventilating air is critical to correct generator operation. Do not alter the installation or permit even partial blockage of ventilation provisions, as this can seriously affect safe operation of the generator. The generator MUST be installed outdoors.
- When working on this equipment, remain alert at all times. Never work on the equipment when physically or mentally fatigued.
- Inspect the generator regularly, and contact the nearest Dealer for parts needing repair or replacement.
- Before performing any maintenance on the generator, disconnect its battery cables to prevent accidental start up. Disconnect the cable from the battery post indicated by a NEGATIVE, NEG or (-) first, then remove the POSITIVE, POS or (+) cable. When reconnecting the cables, connect the POSITIVE cable first, the NEGATIVE cable last.
- Never use the generator or any of its parts as a step. Stepping on the unit can stress and break parts, and may result in dangerous operating conditions from leaking exhaust gases, fuel leakage, oil leakage, etc.

## **ELECTRICAL HAZARDS**

- All generators covered by this manual produce dangerous electrical voltages and can cause fatal electrical shock. Utility power delivers extremely high and dangerous voltages to the transfer switch as does the standby generator when it is in operation. Avoid contact with bare wires, terminals, connections, etc., while the unit is running. Ensure all appropriate covers, guards and barriers are in place, secured and/or locked before operating the generator. If work must be done around an operating unit, stand on an insulated, dry surface to reduce shock hazard.
- Do not handle any kind of electrical device while standing in water, while barefoot, or while hands or feet are wet. DANGEROUS ELECTRICAL SHOCK MAY RESULT.
- The National Electrical Code (NEC) requires the frame and external electrically conductive parts of the generator to be connected to an approved earth ground. Local electrical codes also may require proper grounding of the generator electrical system.

- After installing this home standby electrical system, the generator may crank and start at any time without warning. When this occurs, load circuits are transferred to the STANDBY (generator) power source. To prevent possible injury if such a start and transfer occur, always set the generator's AUTO/OFF/MANUAL switch to its OFF position before working on equipment and remove the fuse from the generator control panel.
- In case of accident caused by electric shock, immediately shut down the source of electrical power. If this is not possible, attempt to free the victim from the live conductor. AVOID DIRECT CONTACT WITH THE VICTIM. Use a nonconducting implement, such as a dry rope or board, to free the victim from the live conductor. If the victim is unconscious, apply first aid and get immediate medical help.
- Never wear jewelry when working on this equipment. Jewelry can conduct electricity resulting in electric shock, or may get caught in moving components causing injury.

## **FIRE HAZARDS**

- For fire safety, the generator must be installed and maintained properly. **Installation must always comply with applicable codes, standards, laws and regulations.** Adhere strictly to local, state and national electrical and building codes. Comply with regulations the Occupational Safety and Health Administration (OSHA) has established. Also, ensure that the generator is installed in accordance with the manufacturer's instructions and recommendations. Following proper installation, do nothing that might alter a safe installation and render the unit in noncompliance with the aforementioned codes, standards, laws and regulations.
- Keep a fire extinguisher near the generator at all times. Extinguishers rated "ABC" by the National Fire Protection Association are appropriate for use on the standby electric system. Keep the extinguisher properly charged and be familiar with its use. Consult the local fire department with any questions pertaining to fire extinguishers.

## **EXPLOSION HAZARDS**

- Do not smoke around the generator. Wipe up any fuel or oil spills immediately. Ensure that no combustible materials are left in the generator compartment, or on or near the generator, as FIRE or EXPLOSION may result. Keep the area surrounding the generator clean and free from debris.
- Gaseous fluids such as natural gas and liquid propane (LP) gas are extremely EXPLOSIVE. Install the fuel supply system according to applicable fuel-gas codes. Before placing the home standby electric system into service, fuel system lines must be properly purged and leak tested according to applicable code. After installation, inspect the fuel system periodically for leaks. No leakage is permitted.

## **OPERATION AND MAINTENANCE**

The operator is responsible for proper and safe use of the equipment. The manufacturer strongly recommends that the operator read this Owner's Manual and thoroughly understand all instructions before using this equipment. The manufacturer also strongly recommends instructing other users to properly start and operate the unit. This prepares them if they need to operate the equipment in an emergency.

It is the operator's responsibility to perform all safety checks, to make sure that all maintenance for safe operation is performed promptly, and to have the equipment checked periodically by an Authorized Service Dealer. Normal maintenance service and replacement of parts are the responsibility of the owner/operator and, as such, are not considered defects in materials or workmanship within the terms of the warranty. Individual operating habits and usage contribute to the need for maintenance service.

Proper maintenance and care of the generator ensures a minimum number of problems and keeps operating expenses at a minimum. See an Authorized Service Dealer for service aids and accessories.

Operating instructions presented in this manual assume that the standby electric system has been installed by an Authorized Service Dealer or other competent, qualified contractor. Installation of this equipment is not a "do-it-yourself" project.

## **HOW TO OBTAIN SERVICE**

When the generator requires servicing or repairs, contact an Authorized Service Dealer for assistance. Service technicians are factory-trained and are capable of handling all service needs (1-800-333-1322).

When contacting an Authorized Service Dealer about parts and service, always supply the complete model number of the unit as given on the front cover of this manual or on the DATA LABEL affixed to the unit.

## **INTRODUCTION**

The Nexus Wireless Monitor consists of two transceivers, one mounted on the generator and the other (display unit) placed in a convenient viewing location within the home. The system has a "line of sight" range of about 200 feet, but this will be reduced when the signal has to pass through walls, floors, etc of a typical installation.

### **NOTE:**

**Some building materials may completely block the passage of the signal. For example: steel beams, metal siding, foil radiant barrier insulation.**

The Nexus Wireless Monitor indicates the generator status via three LED's. The LED's mimic the three status LED's mounted on the home standby generators. The LED operation is described.

This system can be expanded by adding a second display unit to the system.

## **BATTERY INSTALLATION**

The Nexus Wireless Monitor display unit is powered from two non-rechargeable AAA alkaline batteries that are installed by removing the battery cover in the back of the unit. Observe correct battery polarity which is indicated within the battery compartment. The expected battery life under normal use is one year when using standard AAA 1.5V, 1.2Ah alkaline batteries.

### **NOTE:**

**These batteries should be changed yearly.**

The Nexus wireless monitor does not have a power switch, the monitor automatically powers up when the batteries are inserted. Refer to the "Installation" section for more details.

## **NEXUS WIRELESS MONITOR OPERATION**

The Nexus wireless monitor display unit updates the status of its LED's every 30 to 60 seconds. To conserve power and extend battery life, the LED's are not lit continuously; instead they are briefly flashed as indicated below.

None of the conditions indicated on the display unit can be cleared at the display unit. Alarms, warnings, and maintenance alerts all need to be addressed at the generator.

### **GREEN LED (GENERATOR OK)**

The green LED indicates that either:

- The Auto/Off/Manual switch on the generator is set to the Auto position, no alarms are present, and the generator is ready to start and run or is running.

Or

- The Auto/Off/Manual switch on the generator is set to the Manual position, the engine is running and no alarms are active.

When active, the green LED will flash once every 10 seconds.

### **YELLOW LED (MAINTENANCE NEEDED)**

The yellow LED indicates either a GENERATOR WARNING is present or generator maintenance is required. The generator will not be prevented from running when the yellow LED is on.

When active, the yellow LED will flash once every two (2) seconds.

### **RED LED (CONTACT DEALER)**

The red LED indicates any one of the following conditions.

- The Auto/Off/Manual switch on the generator is in the Off position.
- The generator has not been registered.
- A generator alarm is present.
- The Controller has been powered up, but the start up wizard procedure has not been completed.

If a generator alarm is present the generator will not start and run in the event of a utility loss, or will be automatically shut down if the engine is already running.

When active, the red LED will flash once every second.

The internal buzzer will sound once every 30 seconds when the red LED is on. The buzzer can be silenced by briefly pressing and releasing the Pair/Reset button; the buzzer will pulse twice to indicate it has been silenced. The buzzer will not reactivate until a new alarm has been detected.



# Wireless Display System

## NOTE:

The red, yellow and green LED's are also utilized during the pairing process. See the "display unit startup" section for details.

## PAIR/RESET BUTTON

The display unit has a Pair/Reset button on the bottom of the enclosure (Figure 11). The Pair/Reset button has three functions.

- It is used to pair the display unit with the generator transceiver during installation by being pressed and held for 3 seconds. See the installation section for complete instructions.

## NOTE:

If the button is held for 3 seconds during normal operation, the display unit will go into pairing mode which will be indicated by a flashing yellow LED. If this happens simply release the button and allow the display unit to complete its pairing attempt and "fail to pair" which will be indicated by a flashing red LED. Once the red LED begins flashing, momentarily press and release the pair reset button to exit pairing mode. The previously stored pairing information will not be deleted and the display will return to normal operating mode.

- It will silence the internal buzzer when briefly pressed and released.
- It will reset the display unit and remove its pairing information if pressed and held for 10 seconds or more. Avoid this during normal use as the system will cease to operate and the pairing process will need to be performed again.

## INSTALLATION

### GENERATOR SIDE TRANSCIEVER INSTALLATION INSTRUCTIONS - AIR COOLED GENERATORS

The following steps illustrate how to mount the generator side transceiver to an air cooled generator.

For liquid cooled generator applications an adaptor kit is required and comes with additional instructions.

## NOTE:

The generator battery will be disconnected and reconnected during the installation process which may result in an "Inspect Battery" warning being displayed on the generator controller. This is normal and is no cause for concern; simply clear the warning from the generator controller following the operating instructions for the Generator controller. The time and date will also need to be reset once the starting battery is reconnected.

1. Open the top lid of the generator.
2. Set the Auto/Off/Manual switch to the Off position.
3. Remove the 7.5 Amp control panel fuse.
4. Remove the front access panel from the enclosure
5. Disconnect the negative battery cable.

6. If installing after the generator has been connected to utility power, OPEN (turn OFF) the main breaker in your home's utility breaker electrical panel.
7. Remove retaining screws and then remove the control panel cover (Figure 1).

**Figure 1 — Remove Control Panel Cover**



8. Remove the cover plate and rubber gasket from the backside of the generator (Figure 2).

**Figure 2 — Remove Cover Plate & Rubber Gasket**



9. Remove the generator transceiver from the package and verify the gasket is properly located in its groove.
10. Mount the generator transceiver to the generator using the two (2) screws and flat washers provided (Figure 3).

**Figure 3 — Mount Transceiver**



11. Unplug the existing four pin plug connected to the LED board (Figure 4).

**NOTE:**

**Press down on the latch lever to release the latch before trying to pull the plug out of the header. Failure to do so could damage the plug.**

**Figure 4 – Unplug the existing 4-pin plug**



12. Re-route the 4-pin plug, just disconnected, to the generator transceiver. Cut the wire harness tie wraps if necessary.

**NOTE:**

**For pre-2010 models see the Appendix for additional instructions required to complete this step.**

13. Plug the 4-pin plug into the 4-pin header on the generator transceiver (Figure 5). The 4-pin header is the header on the right as you look at the generator transceiver. The plug latch should be to the right when inserting the plug into the header.

**NOTE:**

**The plug can only be inserted into the header one way – DO NOT force the plug into the header; gently insert the plug until it locks into place.**

**Figure 5 - Plug the 4-pin Plug into the Generator Transceiver Module**



14. Connect the wire harness that came with the kit as follows:
  - Insert the 5-pin plug into the 5-pin header on the generator transceiver (Figure 6). DO NOT force the plug into the header. Gently insert the plug until it locks into place. The 5-pin header is the header on the left as you look at the generator transceiver. The plug latch should be to the left when inserting the plug into the header.

**Figure 6 – Plug in the 5-pin plug**



- Route the 4-pin end of the cable back to the LED board and insert it into the 4-pin header on the LED board. (Refer back to Figure 4). DO NOT force the plug into the header. Gently insert the plug until it locks into place.
15. Remove the plastic cover that protects the customer connect terminals and set aside (Figure 7). The plastic cover is not used in pre-2010 models.

**⚠ WARNING!**

**⚡ Multiple AC sources are present at the customer connect terminals.**



# Wireless Display System

**Figure 7 – Remove Plastic Cover**

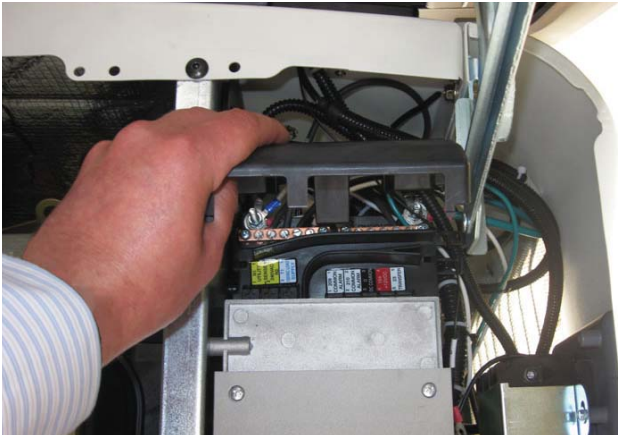

16. Connect the 0 Wire from the wire harness to the 0 location on the terminal strip (Figure 8).

**Figure 8 – Connect the 0 Wire**

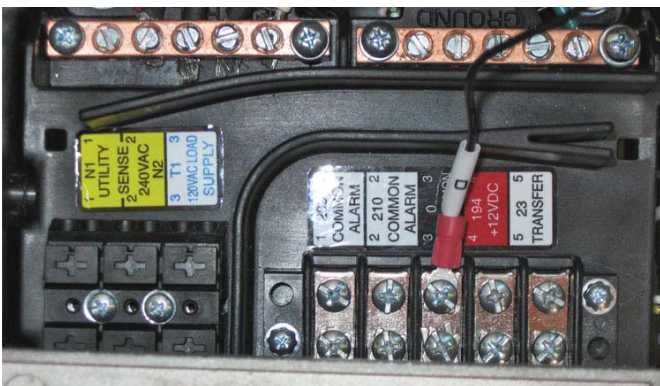

## **DISPLAY UNIT STARTUP**

The Display unit and the generator transceiver are “Paired” at the factory during final test and should start communicating as soon as they are both powered up. If, however, pairing is required (when replacing a module, adding a second display unit, etc.), follow the “Pairing the Generator Transceiver with the Display Unit” procedure.

17. If applicable, CLOSE (turn ON) the breaker in the home's utility breaker electrical panel.
18. Reconnect the negative battery cable.
19. Replace the 7.5 Amp control panel fuse.
20. Install the two non-rechargeable AAA 1.5V batteries (included) into the display unit (Figure 9). Observe correct battery polarity which is indicated within the battery compartment.
21. Close the top lid of the generator. Keeping the lid open may interfere with operation of the wireless module.
22. Verify the display unit begins displaying the generator status correctly. This typically only takes a minute, but could take as long as 12 minutes while the two modules synchronize their internal clocks.
  - If the display unit begins displaying the generator status correctly, skip to the “Re-Assemble the Generator” section.

- If the display unit does not begin displaying the generator status correctly, follow the “Pairing the Generator Transceiver with the Display Unit” procedure.

**Figure 9 – Battery installation**

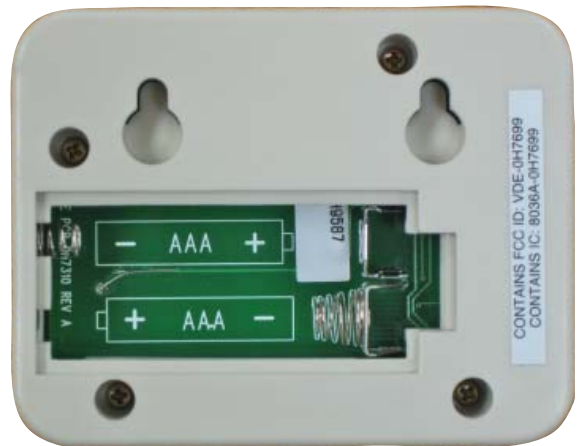

## **Pairing the Generator Transceiver with the Display Unit**

- 23A. See figure 11 for the location of the “Pair/Reset” button on the display unit.

Place the display unit against the generator transceiver as shown in figure 10, then immediately press and hold the “Pair/Reset” button on the display unit
- 23B. Once the yellow LED begins flashing (after about three seconds), indicating the modules are in pairing mode, release the “Pair/Reset” button on the display unit and move the display unit away from the generator transceiver.
24. The Yellow LED will continue to flash during the pairing process.
25. Once the two modules have successfully paired up the yellow LED will stop flashing and the green LED will begin flashing.
26. Press and release the Pair/Reset button to complete the pairing process. At this time the green LED will stop flashing and the display unit will enter its normal mode of operation.

**Figure 10 – Place the Display Unit Against the Generator Transceiver**

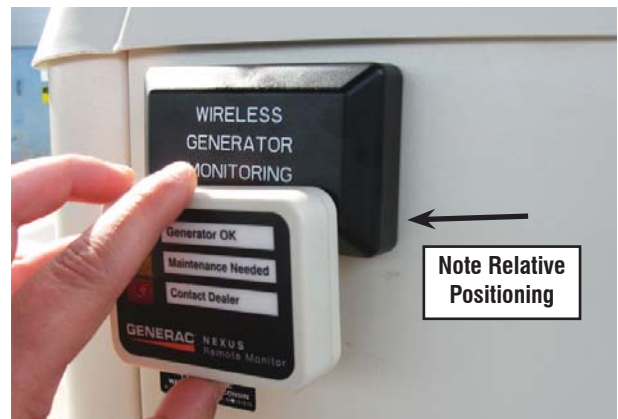



**NOTE:**

If the Auto/Off/Manual switch is still in the off mode the red LED will begin to flash to indicate the generator is in alarm mode. Do not confuse this flashing red LED with the “failure to pair” described below.

**NOTE:**

The magnets in the display unit activate a magnetic reed switch in the generator transceiver in step 21. The relative positioning of the two units needs to be as shown in Figure 10 to activate the magnetic reed switch.

**Figure 11 – Location of Pair/Reset Button**

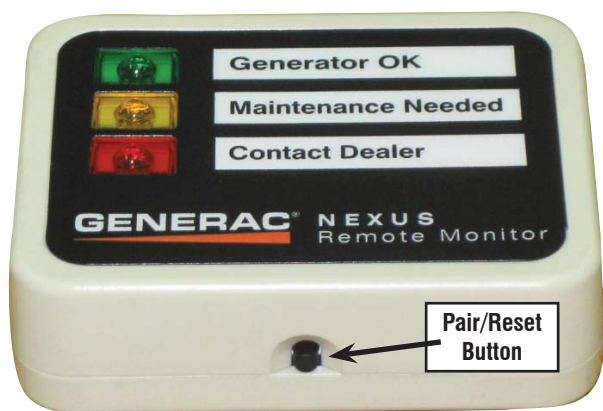

27. Proceed with the “Re-Assemble the Generator” section
28. If the two modules fail to pair up within 30 seconds, the yellow LED will stop flashing and the red LED will begin to flash. If this happens proceed as follows:
  - Press and release the Pair/Reset button to stop the red LED from flashing.
  - Check that good non-rechargeable AAA 1.5V batteries are installed.
  - Check the wiring to make sure all the plugs are fully inserted.
  - Repeat the pairing process from step 21A.

**RE-ASSEMBLE THE GENERATOR**

29. Open the top lid of the generator.
30. Remove the 7.5 Amp control panel fuse.
31. If needed, use tie wraps to secure the new wire harnesses.
32. Replace the plastic cover over the customer connect terminals.
33. Replace the control panel cover and retaining screws.
34. Replace the front access panel.
35. Replace the 7.5 Amp control panel fuse.
36. Set the Auto/Off/Manual switch to the Auto position.
37. Close the top lid of the generator.

**Information Label**

A write on label has been provided for adding the generator serial number and dealer information for easy reference (Figure 12).

**Figure 12 – Information label**



**DISPLAY UNIT MOUNTING**

The display unit has two internal magnets allowing it to be easily attached to any magnetic surface such as a refrigerator. The display unit also has two mounting holes in the back which can be used to mount it to a wall. See figure 13 for mounting hole locations.

**Figure 13 – Mounting hole locations**

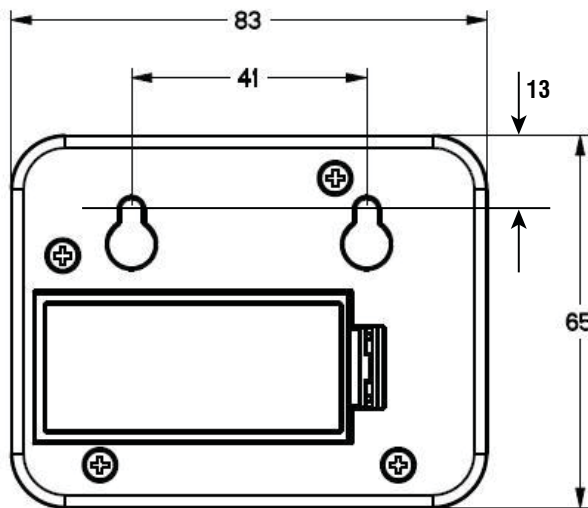

**NOTE:**

The display unit is intended to be mounted indoors only. Avoid mounting the display unit in wet or damp locations.

# Wireless Display System

## ADDING A SECOND DISPLAY UNIT TO THE SYSTEM

A second display unit can be added to an existing system as follows:

1. Install two non-rechargeable AAA 1.5V batteries into the second display unit. Observe correct battery polarity which is indicated within the battery compartment.
2. Follow steps 21A through 24 in the "Installation" section.

### NOTE:

Adding a second display unit to an existing system will not affect the pairing information in the original display unit. The original display unit will continue to function normally.

## APPENDIX

### RETROFITTING THE NEXUS REMOTE MONITOR INTO A PRE-2010 MODEL GENERATOR

The Nexus Remote Monitor was developed for the 2010 Home Standby product line but is also compatible with several of the 2008 and 2009 Home Standby models.

- It is fully compatible with 2008/09 17 and 20kW models with 3 status LED's on the side panel.
- It is compatible with 2008/09 10 and 14kW models with 2 status LED's on the side panel, except the yellow Maintenance LED on the Nexus Remote Monitor will not function.
- It is not compatible with 2008/09 8kW models.

The 4-wire LED wire harness in pre-2010 models needs to be separated from the main wire harness to provide enough length to reach the generator transceiver.

The following instructions replace Step 11 in the general installation instructions.

1. Remove the four screws holding the control panel in place.
2. Lift the control panel up and move it out of the way (Figure 1).

**Figure 1 — Remove the Control Panel**

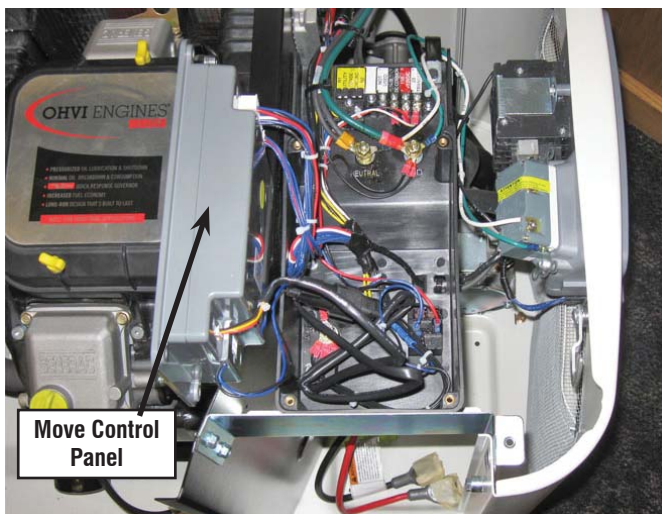

3. Cut the tie wrap holding the 4-wire LED wire harness to the enclosure (Figure 2, "A").
4. Carefully cut and remove the tape from the main wire harness. (Figure 2, "B").
5. Temporarily pull the 4-wire LED wire harness up through the hole in the control panel (Figure 2, "C").

**Figure 2 — 4-wire LED Wire Harness Position**

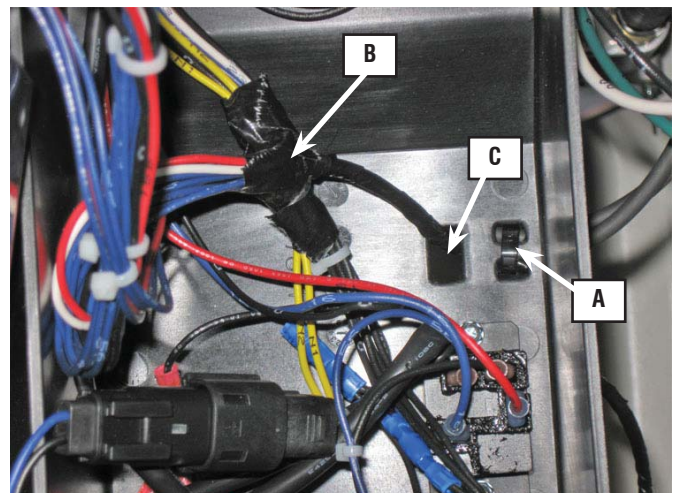

6. Separate the 4-wire LED wire harness from the rest of the wire harness, cutting and removing all but the last tie wrap (Figure 3, "D") holding the 4-wire LED harness (Figure 3, "E") to the main harness.

**Figure 3 — Separate the 4-wire LED Wire Harness from Main Harness**

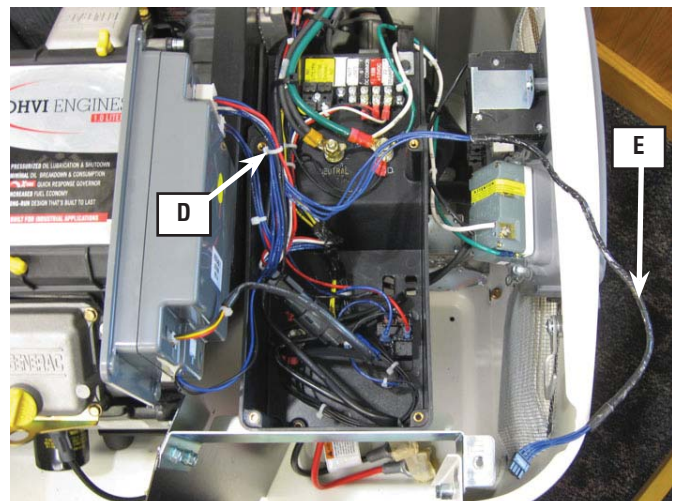

7. Route the 4-wire LED wire harness back down through the hole in the control panel (refer back to Figure 2, "C").
8. Route the 4-wire LED wire harness back to the generator transceiver, making sure there is enough wire length to plug into the Generator Transceiver.
9. Replace the control panel and secure with the four mounting screws.
10. Return to step 12 in the general installation instructions.

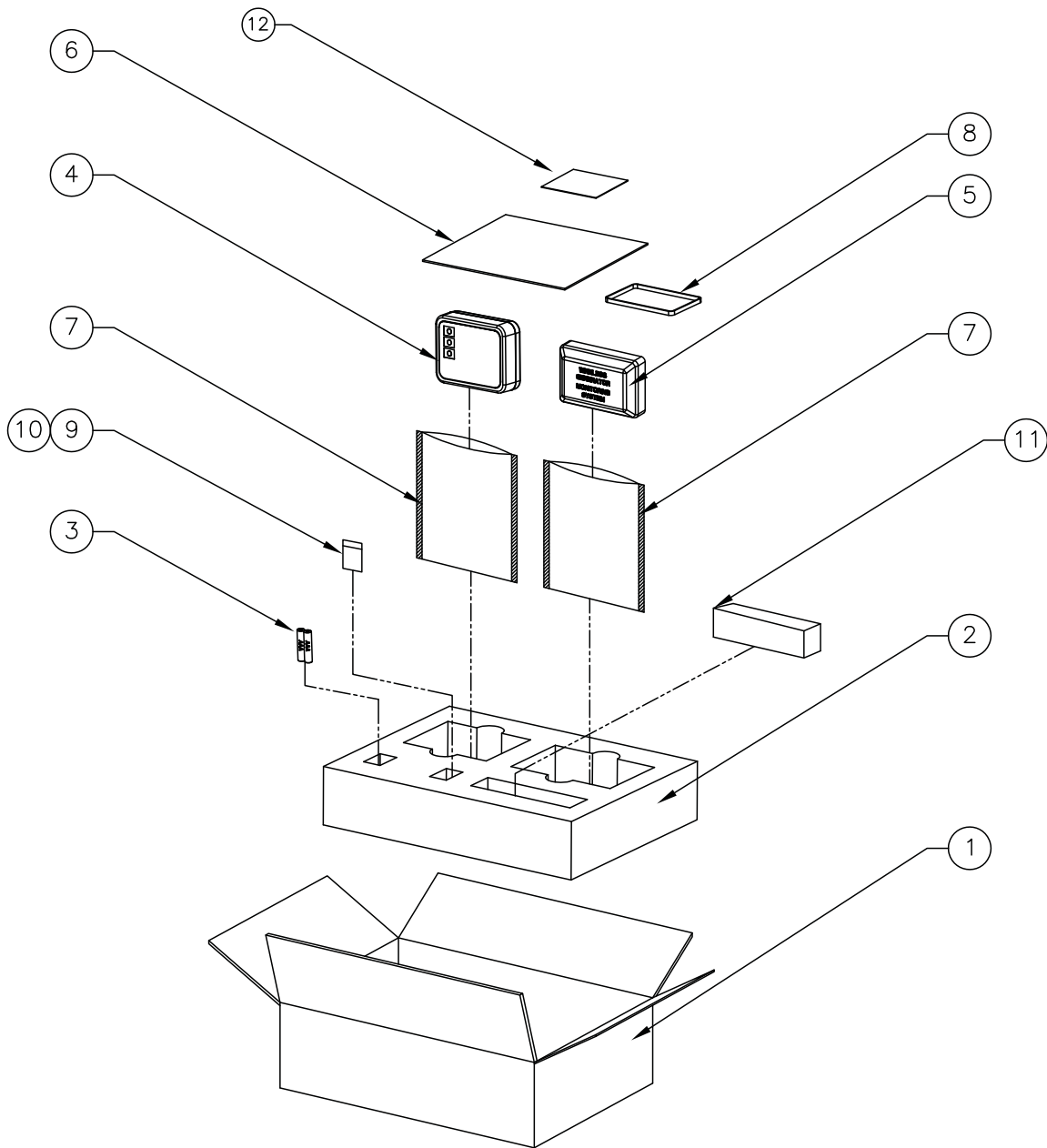

ITEM	PART NO.	QTY.	DESCRIPTION
1	OG7127	1	CARTON 306 X 227 X 80
2	0H9607	1	PE FOAM
3	OG7161	2	BATTERY, AAA
4	0H8075	1	BASIC WIRELESS 2010H
5	0H9593	1	GENERATOR SIDE RF ANNUNCIATOR
6	0H9608	1	MANUAL
7	OG7130	2	STATIC SHIELDING BAG, 200 X 140 X 0.08mm
8	OG7092	1	GASKET, 2.0 X 4.0 X 313
9	084543A	2	SCREW PPPH 3 X 12mm
10	052777	2	WASHER FLAT M3
11	0H8352	1	HARN PCB TO BASIC RF MODULE
12	OJ6820	1	BASIC WIRELESS QUICK START

# Warranty

## **GENERAC POWER SYSTEMS “180 DAY” LIMITED WARRANTY FOR WIRELESS REMOTE MONITOR (for AIR-COOLED GENERATORS)**

For a period of 180 days from the date of original sale, Generac Power Systems, Inc. (Generac) warrants its wireless remote monitor will be free from defects in materials and workmanship for the items and period set forth below. Generac will, at its discretion, repair or replace any part that, upon examination, inspection and testing by Generac or a Generac Authorized Warranty Service Dealer, is found to be defective. Any equipment that the purchaser/owner claims to be defective must be returned to and examined by the nearest Generac Authorized Warranty Service Dealer. All transportation costs under the warranty, including return to the factory, are to be borne and prepaid by the purchaser/owner. This warranty applies only to Generac wireless remote monitor and is not transferable from original purchaser.

The warranty period begins on the date of purchase by the first retail end user, and continues for the period of time stated above. “Consumer Application” means personal residential household use by a retail consumer. No other use is warranted.

### **CONSUMER APPLICATION**

180 Day - Limited comprehensive coverage on Labor and Parts

#### **THIS WARRANTY SHALL NOT APPLY TO THE FOLLOWING:**

1. Any travel expenses to troubleshoot, remove, replace or adjust a part(s).
2. Normal customer maintenance items.
3. Failures due, but not limited, to the following:
  - Storage
  - Improper installation
  - Improper repair/diagnosis
  - Improper maintenance
  - Normal wear and tear
  - Misuse
  - Abuse
  - Accident
  - Misapplication
  - Negligence
4. Failures caused by any external cause or act of God, such as collision, theft, vandalism, riot or wars, nuclear holocaust, fire, freezing, lightning, earthquake, windstorm, hail, volcanic eruption, water or flood, tornado or hurricane.
5. Products and/or part(s) that are modified or altered in a manner not authorized by Generac in writing.
6. Any incidental, consequential or indirect damages caused by defects in materials or workmanship, or any delay in repair or replacement of the defective part(s).
7. Failure due to misapplication.
8. Telephone, telegraph, teletype or other communication expenses.
9. Living or travel expenses of person(s) performing service, except as specifically included within the terms of a specific unit warranty period.
10. Rental equipment used while warranty repairs are being performed.
11. Freight costs for replacement part(s).
12. Labor charges.

THIS WARRANTY IS IN PLACE OF ALL OTHER WARRANTIES, EXPRESSED OR IMPLIED. SPECIFICALLY, GENERAC MAKES NO OTHER WARRANTIES AS TO THE MERCHANTABILITY OR FITNESS FOR A PARTICULAR PURPOSE. Any implied warranties which are allowed by law, shall be limited in duration to the terms of the express warranty provided herein. Some states do not allow limitations on how long an implied warranty lasts, so the above limitation may not apply to you. GENERAC'S ONLY LIABILITY SHALL BE THE REPAIR OR REPLACEMENT OF PART(S) AS STATED ABOVE. IN NO EVENT SHALL GENERAC BE LIABLE FOR ANY INCIDENTAL OR CONSEQUENTIAL DAMAGES, EVEN IF SUCH DAMAGES ARE A DIRECT RESULT OF GENERAC'S NEGLIGENCE.

Some states do not allow the exclusion or limitation of incidental or consequential damages, so the above limitation may not apply to you. This warranty gives you specific legal rights. You may also have other rights from state to state.

#### **GENERAC POWER SYSTEMS, INC.**

S45 W29290 Hwy. 59 • Waukesha, WI 53189 • Ph: (888) GENERAC (436-3722) • Fax: (262) 544-4851  
To locate the nearest Authorized Dealer visit our website at [www.generac.com](http://www.generac.com)

Part No. 0H1608

Rev. C (09/12)

#### **PROCEDURE FOR FILING CLAIM:**

If you encounter a problem with your remote monitor, please review the installation and programming sections to ensure that the guidelines were followed. If a problem still exists, please contact 888-GENERAC (888-436-3722) for assistance and have your proof of purchase available for verification. After speaking with a customer service representative, a decision will be made if a replacement remote monitor will be sent out to you free of charge. Generac Power Systems recommends that the installation of the remote monitor be performed by a qualified installer/dealer.

**NOTE: Labor and travel charges ARE NOT allowed under this factory warranty.**