

Commercial generator set Quiet Gasoline™ Series QG 5500



Cummins Onan

Performance you rely on.™



Features and benefits

- Integrated hydraulic pump option (pictured)
- Quietest and lowest vibration generator set in its class
- Integrated housing design
- Enclosed muffler for ease of installation
- Self-diagnostic capability to simplify troubleshooting
- Runs two ACs
- Digital regulation for voltage stability as loads change
- 2-year limited warranty, 5-year drive warranty

Weight, size and sound level

Weight: 290 lb (132 kg)

Size: Length 33.6 in (853 mm), width 22.2 in (563 mm), height 16.7 in (425 mm)

Sound: 66 dB(A) at 10 ft (3 m), typical installation, full load

Models and ratings

Model	Fuel	Hz	Watts	Voltage	Amps	PF	Phase	Circuit breaker
5.5 HGJAE-2131	Gasoline	60	5500	120	45.8	1.0	1	2 pole, 30 A
5.5 HGJAE-2555#	Gasoline	60	5500	120/240	22.9	1.0	1	2 pole, 30 A
5.5 HGJAE-2135	Gasoline	60	5500	120/240	22.9	1.0	1	2 pole, 30 A
5.5 HGJAE-6757♦	Gasoline	60	5500	120/240	22.9	1.0	1	2 pole, 30 A
5.5 HGJAE-2136	Gasoline	60	5500	120/240	13.2	1.0	3	3 pole, 18 A
5.5 HGJAE-2144	LP vapor	60	5500	120/240	22.9	1.0	1	2 pole, 30 A

- All 60 Hz models operate at 2400 r/min.
- Ratings apply up to 3000 ft (914 m) altitude, 85 °F (29.4 °C).
- Derating: Power output will decrease 3.5% for each 1000 ft (305 m) above 3000 ft (914 m), temperature derate not required for ambient** temperatures under 120 °F (49.2 °C).
- Ratings are at intermittent power output

Splined shaft.

** Ambient is defined as the air temperature measured at the cooling air inlet to the set.

♦ Evaporative spec: For trailer applications required to meet Tier III Evaporative emissions of the California Air Resources board.

Effective January 1, 2011, gasoline generator sets on trailers, diesel chassis or any other non-motorized mobile apparatus must have an EVAP generator set, approved tank, EVAP canister, hoses and fittings all meeting the CARB Tier 3 and EPA phase 3 standards and specifications. This law applies in all 50 states.

Cummins®, Onan®, the "C" logo, Performance you rely on.™ and Quiet Gasoline™ are servicemarks, trademarks and/or registered trademarks of Cummins Inc.

Specifications are subject to change without notice

©2012 Cummins Power Generation. All Rights Reserved.

A-1440i (3/12)

Standard features

- Mechanical governor adjustable from service side
- Cummins Onan OHV engine
- Pressurized thru flow cooling system
- 4-point mounting system with coil spring vibration isolators
- Universal mounting tray with structural capability to support the generator set in commercial mobile applications
- Integral USDA Forest Service-approved spark-arrestor muffler
- Integral control box
- Instant one-touch stop switch
- Electronic ignition
- Self diagnostic capability
- Battery charging - 5 A
- Hour meter
- Remote disable/continuous stop
- Start and run without AC output - engine run only
- Enclosed muffler provides noise reduction and ease of installation
- Sound-attenuated housing
- Waterproof remote connector
- Heavy-duty solenoid shift starter
- Fuel filter
- Spin-on, full-flow oil filter
- Low oil pressure protection
- Over/under speed protection
- Low power factor field over current protection
- Digital voltage regulation
- Hydraulic pump standard on some models
- 10 ft generator set output lead

Typical fuel consumption

5.5 HGJAE

Gasoline, Gal/hr (L/hr)

LP Vapor, Gal/hr (L/hr)

No load

0.35 (1.3)

0.40 (1.8)

Engine details

Model: Cummins Onan OHV EH65V gasoline engine

Design: 4-cycle, OHV, 90-degree V-twin

Cylinders: 2

Bore: 80 mm

Stroke: 65 mm

Displacement: 39.8 in³ (653 cm³)

Compression ratio: 8:1

Oil capacity: 2.0 qt (1.9 L) including filter

Power (max): Gasoline-fueled models: at 2400 r/min: 12.9 hp, LP-fueled models: at 2400 r/min: 10.7 hp

Cooling: Centrifugal blower, generator set mounted for high effectiveness, pressurized system, vertical flow

Cooling air volume: 60 Hz: 500 ft³/min (14.2 m³/min) at 2400 r/min. Air flow includes engine, generator set and control cooling air flow

Fuel system:

- Replaceable dry element air cleaner

- Gasoline - sidedraft carburetor

Electronic fuel pump with positive fuel shutoff (3 psi), maximum fuel lift 3 ft (0.9 m)

Automatic choke with vacuum pull-off

Combustion air volume: 60 Hz: 17.2 ft³/min (0.48 m³/min) at 2400 r/min

- LPG - sidedraft mixer with demand regulator

Combustion air volume: 60 Hz: 17.6 ft³/min (0.49 m³/min) at 2400 r/min

Starting system: Remote, 12 V, negative ground; automotive type starter with steel pinion and ring gear, automatic start disconnect, connector for remote start cable, start-stop rocker switch mounted on set control

Ignition system: Electronic magneto type with resistor plugs

Lubrication: Full pressure positive displacement lube oil pump, spin-on, full-flow lube oil filter, low oil pressure shutdown, dipstick

Cylinder crankcase: Alloy aluminum with iron cylinder liners cast into the block, aluminum oil base

Cylinder head: Aluminum, OHV, removable

Alternator details

Design: Cummins Onan, revolving field, AC, 2-pole self-excited, two bearing design

Insulation system and temperature rise: Meets requirements of NEMA MG-1 and CSA C22.2, Std. 100 Motors and Generators

Cooling: Direct drive centrifugal blower, cast aluminum housing for excellent heat transfer

Rotor: Laminated electrical steel assembly press-fitted to shaft, balanced; heavy insulated copper wire windings; optimized air gap for improved waveform and motor starting; Class 200 magnet wire

Stator: Laminated electrical steel assembly, skewed for improved waveform; Class 200 quadrature wire with 70% more insulation over comparable generator sets

Frequency regulation

No load/Full load

5.0%

Constant load

1.7%

Voltage regulation

No load/Full load

2.0%

Constant load

1.7%

Excitation: Capped, digital voltage regulation

DC brushes: Electrographic; long life

Bearing: Double-sealed pre-lubricated ball bearings

Generator set details

Hydraulic pump

- Fixed displacement gear pump, 1.5 Gal/min at 2500 psi

- A generator set with a hydraulic pump is rated with the pump idle

- When using a non-Cummins Onan pump supplied by the customer, the hydraulic pump shaft seals must be capable of operating in a temperature environment of 225° F to 250° F. Seal failure will result in equipment damage

Cummins®, Onan®, the "C" logo, Performance you rely on.™ and Quiet Gasoline™ are servicemarks, trademarks and/or registered trademarks of Cummins Inc.

Specifications are subject to change without notice

©2012 Cummins Power Generation. All Rights Reserved.

A-1440i (3/12)

Basic dimensions

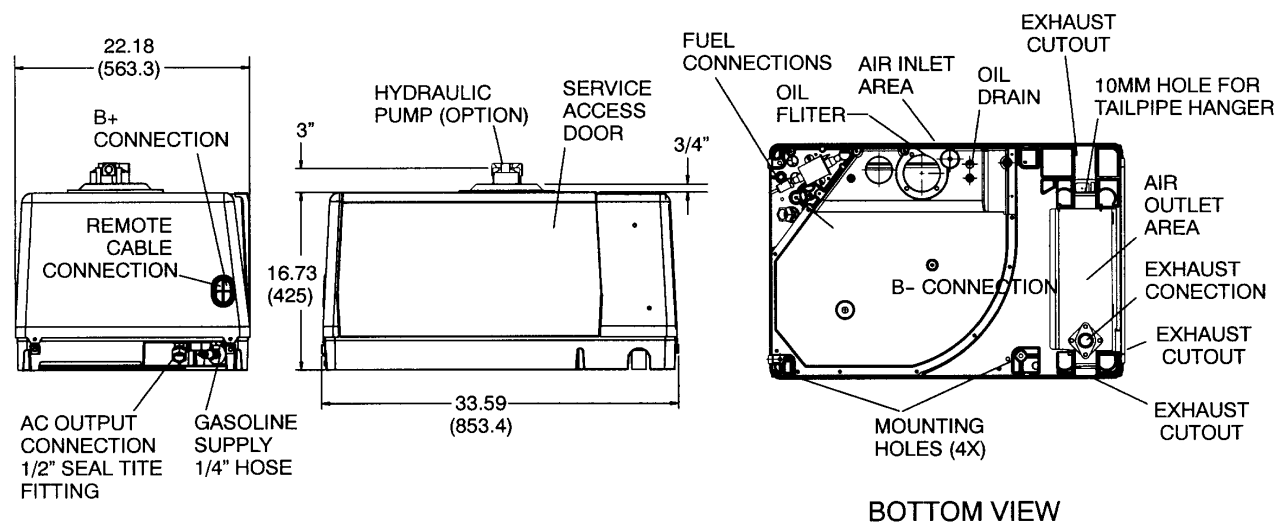

Note: This outline drawing is provided for general reference only and is not intended for design or installation. For more information see Operation and Installation manuals or obtain drawing 500-3349 and wiring diagram from your distributor/dealer.

Options and accessories

- Remote control start/stop rocker switch (P/N 300-5331)
- Remote control with start/stop switch and hour meter (P/N 300-5332)
- Remote control with start/stop switch and DC voltmeter (P/N 300-5333)
- Remote control plug and wire harness 10 ft (P/N 338-3489-01), 30 ft (P/N 338-3489-02)
- Remote harness (P/N 300-4946) pigtail harness to connect to sealed remote connector
- LPG vapor fuel conversion kit (P/N 148-1161)
- Under floor mounting kit (P/N 405-6699)
- Installation template (P/N 539-2057)
- Tailpipe kit 22 in (P/N 155-3481-01), 26 in (P/N 155-3481-02)
- Exhaust tube, straight with flanged end 3 in (P/N 155-2610), 7 in (P/N 155-2424), 12.5 in (P/N 155-2610-01)
- Exhaust elbow, tight radius 90° to route exhaust through cutouts (P/N 155-3439)

Standards and testing

- Tested at extremes of temperature -20 °F (-29 °C) to 120 °F (49 °C) for starting and operation
- Tested installed
- Tested with commercial loads
- Tested in high humidity conditions
- Tested in salt spray conditions
- Tested in heavy airborne dust conditions
- Field test program
- 60 Hz models meet applicable U.S. EPA and California emissions standards
- This generator set was designed and manufactured in facilities certified to ISO 9001
- CSA certified for CSA C22.2 std 100 and std 14



Warranty policy

The Cummins Onan limited warranty covers virtually everything except routine maintenance for the first two years you own your generator set, or the first 2,000 hours of operation, whichever comes first. In addition, it includes a free 90-day adjustment policy, which provides that Cummins Inc. will make minor adjustments to your new generator set during the first three months you own it - free of charge!

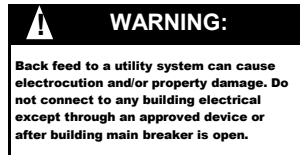
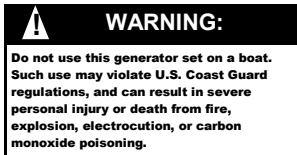

After sale support

Largest distributor/dealer support network

Cummins Onan generator sets are supported by the largest and best trained worldwide certified distributor/dealer network in the industry. This network of knowledgeable Cummins Onan distributor/dealers will help you select and install the right generator set and accessories to meet the requirements of your specific application. This same network offers a complete selection of commonly used generator set maintenance parts, accessories and products plus manuals and specification sheets. Plus, they can answer your questions regarding proper operation, maintenance schedules and more.

Manuals: Operation and installation manuals ship with the generator set. To obtain additional copies or other manuals for this model, see your Cummins Onan distributor/dealer and request the following manual numbers: Operation (A035D007), Installation (A035D003) Parts (983-0202 I10), Service (A035D011).

To easily locate the nearest Cummins Onan distributor/dealer in your area, or for more information, contact us at 1-800-888-6626 (or 763-574-5000), or visit www.cumminsonan.com.

Contact your distributor/dealer for more information

Cummins Onan

Cummins Power Generation

1400 73rd Ave. NE
Minneapolis, MN 55432 USA
Phone 1 763 574 5000
Toll-free 1 800 888 6626
Fax 1 763 574 5298
Email www.cumminsonan.com/contact
www.cumminsonan.com

