



# Owner's Manual and Installation Instructions

Liquid-cooled Recreational Vehicle Generator

- Model: 005432-0  
QUIETPACT™ 85D



This manual should remain with the unit.

## INTRODUCTION

Thank you for purchasing this model by Generac Power Systems, Inc. This model is designed and manufactured to supply electrical power for recreational vehicles.

### ◆ READ THIS MANUAL THOROUGHLY

If any portion of this manual is not understood, contact the nearest Authorized Service Dealer for starting, operating, and servicing procedures.

Throughout this publication, and on tags and decals affixed to the generator, DANGER, WARNING, CAUTION, and NOTE blocks are used to alert personnel to special instructions about a particular operation that may be hazardous if performed incorrectly or carelessly. Observe them carefully. Their definitions are as follows:



**After this heading, read instructions that, if not strictly complied with, will result in serious personal injury, including death, or property damage.**



**After this heading, read instructions that, if not strictly complied with, may result in personal injury or property damage.**



**After this heading, read instructions that, if not strictly complied with, could result in damage to equipment and/or property.**

#### NOTE:

**After this heading, read explanatory statements that require special emphasis.**

These safety warnings cannot eliminate the hazards that they indicate. Common sense and strict compliance with the special instructions while performing the service are essential for preventing accidents.

Four commonly used safety symbols accompany the Danger, Warning, and Caution blocks. Here are the types of information indicated by each symbol:

 This symbol points out important safety information that, if not followed, could endanger personal safety and/or property to self and others.

 This symbol points out potential explosion hazard.

 This symbol points out potential fire hazard.

 This symbol points out potential electrical shock hazard.

The operator (i.e., the driver) is responsible for the proper and safe use of the vehicle and its equipment, and for the safety of all vehicle occupants. Before using this equipment, we strongly recommend that the operator read this manual and thoroughly understand all instructions. We also strongly recommend instructing other occupants in the vehicle to properly start and operate the generator. This prepares them to operate the equipment in case of an emergency.

### ◆ CONTENTS

This manual contains pertinent owner's information, including warranty, electrical diagrams, exploded views, and lists of repair parts for generator model number 005432-0. In addition, the latter portion of this manual contains information necessary for the proper installation of these generators.

### ◆ OPERATION AND MAINTENANCE

It is the operator's responsibility to perform all safety checks, to make sure that all maintenance for safe operation is performed promptly, and to have the equipment checked periodically by an Authorized Service Dealer. Normal maintenance service and replacement of parts are the responsibilities of the owner/operator and, as such, are not considered defects in materials or workmanship within the terms of the warranty. Individual operating habits and usage contribute to the need for maintenance service.

Proper maintenance and care of the generator minimizes problems and operating expenses. See the Authorized Service Dealer for service aids and accessories.

### ◆ HOW TO OBTAIN SERVICE

When the generator requires servicing or repairs, simply contact an Authorized Service Dealer for assistance. Service technicians are factory-trained and are capable of handling all service needs.

When contacting an Authorized Service Dealer or the factory about parts and service, always supply the complete model parts and serial number of the unit, as given on its data label, which is located on the generator.

Model No. \_\_\_\_\_ Serial No. \_\_\_\_\_

## AUTHORIZED SERVICE DEALER LOCATION

To locate the nearest AUTHORIZED  
SERVICE DEALER, please call this number:

**1-800-333-1322**

or locate us on the web at

**www.generac.com**

## **Part I – Owner’s Manual**

## **Part II – Installation Instructions**

<b>Introduction .....</b>	<b>Inside Front Cover</b>
Read This Manual Thoroughly .....	IFC
Contents.....	IFC
Operation and Maintenance .....	IFC
How to Obtain Service.....	IFC
Authorized Service Dealer Locator Number.....	IFC
<b>Safety Rules .....</b>	<b>2</b>
<b>Section 1 – General Information .....</b>	<b>4</b>
1.1 Generator Identification .....	4
1.2 Generator Applicability .....	5
1.3 Safety .....	5
1.4 Generator AC Connection System .....	5
1.5 Specifications .....	5
<b>Section 2 – Operation .....</b>	<b>7</b>
2.1 Generator Control Panel.....	7
2.2 Optional Remote Start/Stop .....	8
2.3 Before Starting the Engine .....	8
2.4 Starting the Generator .....	9
2.5 Stopping the Generator .....	9
2.6 Applying Loads to Generator.....	9
2.7 Protection Systems.....	10
2.8 Additional Information .....	10
<b>Section 3 – Maintenance.....</b>	<b>11</b>
3.1 Checking the Engine Oil Level.....	11
3.2 Changing the Engine Oil and/or Oil Filter .....	11
3.3 Servicing the Engine Air Filter .....	12
3.4 Spark Arrestor Muffler.....	12
3.5 Cleaning the Generator .....	13
3.6 Battery Maintenance.....	13
3.7 Cooling System.....	14
3.8 Engine Coolant.....	14
3.9 Major Service Manual.....	14
3.10 Drive Belt .....	14
3.11 Exercising the Generator.....	14
3.12 Out-of-Service Procedure.....	15
3.13 Service Schedule .....	16

<b>Safety Rules .....</b>	<b>18</b>
<b>Section 1 – General Information .....</b>	<b>20</b>
1.1 Purpose and Scope of the Manual.....	20
1.2 Safety .....	20
1.3 Standards Booklets.....	20
1.4 Equipment Description .....	20
1.5 Generator Engine Operating Speed .....	20
1.6 Generator AC Connection System .....	20
Major Features and Dimensions.....	21
<b>Section 2 – Installation .....</b>	<b>22</b>
2.1 Location and Support .....	22
2.2 Generator Compartments .....	23
2.3 Cooling and Ventilating Air .....	26
2.4 Diesel Fuel System .....	27
2.5 Exhaust System.....	29
2.6 Electrical Connections.....	30
2.7 Battery Installation.....	33
2.8 Optional Accessories .....	34
<b>Section 3 – Post-installation Startup Checks.....</b>	<b>35</b>
3.1 Post Installation Tests .....	35
3.2 Before Initial Startup.....	35
3.3 Initial Start.....	35
3.4 Testing Under Load.....	35
3.5 Installation Checklist.....	36
<b>Section 4 – Troubleshooting.....</b>	<b>37</b>
4.1 Troubleshooting Guide.....	37
<b>Section 5 - Electrical Data .....</b>	<b>38</b>
<b>Section 6 – Exploded Views and Parts Lists.....</b>	<b>44</b>
<b>Section 7 – Warranty .....</b>	<b>68</b>



**⚠ SAVE THESE INSTRUCTIONS – The manufacturer suggests that these rules for safe operation be copied and posted in potential hazard areas of the recreational vehicle. ⚠**  
**Safety should be stressed to all operators and potential operators of this equipment.**

**WARNING:**

**The engine exhaust from this product contains chemicals known to the state of California to cause cancer, birth defects, or other reproductive harm.**

**WARNING:**

**This product contains or emits chemicals known to the state of California to cause cancer, birth defects or other reproductive harm.**

Study these SAFETY RULES carefully before installing, operating, or servicing this equipment. Become familiar with this manual and with the unit. The generator can operate safely, efficiently, and reliably only if it is properly installed, operated, and maintained. Many accidents are caused by failing to follow simple and fundamental rules or precautions.

The manufacturer cannot anticipate every possible circumstance that might involve a hazard. The warnings in this manual, and on tags and decals affixed to the unit, are, therefore, not all-inclusive. If using a procedure, work method, or operating technique that the manufacturer does not specifically recommend, ensure that it is safe for others. Also make sure the procedure, work method, or operating technique utilized does not render the generator unsafe.

— **⚠ DANGER ⚠** —

- ⚠ Despite the safe design of this generator, operating this equipment imprudently, neglecting its maintenance, or being careless can cause possible injury or death. Permit only responsible and capable persons to operate and maintain this equipment.**
- ⚠ Parts of the generator are rotating and/or hot during operation. Exercise care near running generators.**
- ⚠ Potentially lethal voltages are generated by these machines. Ensure all steps are taken to render the machine safe before attempting to work on the generator.**

**⚠ GENERAL HAZARDS ⚠**

- For safety reasons, the manufacturer recommends that the installation, initial startup, and maintenance of this equipment be performed by an Authorized Service Dealer.

- The generator engine releases DEADLY carbon monoxide gas through its exhaust system. This dangerous gas, if breathed in sufficient concentrations, can cause unconsciousness or even death. Never operate the generator set with the vehicle inside any garage or other enclosed area. **DO NOT OPERATE THE GENERATOR IF THE EXHAUST SYSTEM IS LEAKING OR HAS BEEN DAMAGED.** SYMPTOMS OF CARBON MONOXIDE POISONING ARE (a) inability to think coherently, (b) nausea, (c) vomiting, (d) twitching muscles, (e) throbbing temples, (f) dizziness, (g) headaches, (h) weakness, and (i) sleepiness. **IF EXPERIENCING ANY OF THESE SYMPTOMS, MOVE INTO FRESH AIR IMMEDIATELY. IF SYMPTOMS PERSIST, GET MEDICAL HELP.** Shut down the generator and do not operate it until it has been inspected and repaired.
- Never sleep in the vehicle while the genset is running unless the vehicle has a working carbon monoxide detector. The exhaust system must be installed in accordance with the genset installation manual. Make sure there is ample fresh air when operating the genset in a confined area.
- The engine exhaust fumes contain carbon monoxide, which can be DEADLY. This dangerous gas, if breathed in sufficient concentrations, can cause unconsciousness or even death. Thus, the exhaust system must be installed properly, in strict compliance with applicable codes and standards. Following installation, do nothing that might render the system unsafe or in noncompliance with such codes and standards. The generator compartment must be completely vapor-sealed from the vehicle interior. There must be no possibility of exhaust fumes entering the vehicle interior. Never operate this equipment with a leaking or defective exhaust system.
- Keep hands, feet, clothing, etc., away from drive belts, fans, and other moving or hot parts. Never remove any drive belt or fan guard while the unit is operating.
- Adequate, unobstructed flow of cooling and ventilating air is critical to correct generator operation and is required to expel toxic fumes and fuel vapors from the generator compartment. Without sufficient cooling airflow, the engine/generator quickly overheats, which seriously damages the generator. Do not alter the installation or permit even partial blockage of ventilation provisions, as this can also seriously affect the safe operation of the generator.



- When working on this equipment, remain alert at all times. Never work on the equipment when physically or mentally fatigued.
- Inspect the generator regularly, and contact the nearest Authorized Service Dealer immediately for parts needing repair or replacement.
- Before performing any maintenance on the generator, disconnect its battery cables to prevent accidental startup. First, disconnect the cable from the battery post, indicated by a NEGATIVE, NEG, or (-). Reconnect this cable last.
- Never use the generator, or any of its parts, as a step. Stepping on the unit can stress and break parts, resulting in dangerous operating conditions due to leaking exhaust gases, fuel leakage, oil leakage, etc.
- Never insert any tool or other object through openings in the generator interior, even if the unit is not running. Serious injury or damage to the equipment could be done.

### **ELECTRICAL HAZARDS**

- The generator covered by this manual produces dangerous electrical voltages and can cause fatal electrical shock. Avoid contact with bare wires, terminals, connections, etc., while the unit is running. Before operating the generator, ensure all appropriate covers, guards, and barriers are in place. If work must be done around an operating unit, stand on an insulated, dry surface to reduce shock hazard.
- Do not handle any kind of electrical device while standing in water, while barefoot, or while hands or feet are wet. DANGEROUS ELECTRICAL SHOCK MAY RESULT.
- During installation onto the vehicle, have the generator properly grounded (bonded), either by solid mounting to the vehicle frame or chassis, or by means of an approved bonding conductor. DO NOT disconnect the bonding conductor, if so equipped. DO NOT reconnect the bonding conductor to any generator part that might be removed or disassembled during routine maintenance. If the grounding conductor must be replaced, use only a flexible conductor that is of No. 8 American Wire Gauge (AWG) copper wire minimum.
- In case of an accident caused by electric shock, immediately shut down the source of electrical power. If this is not possible, attempt to free the victim from the live conductor. AVOID DIRECT CONTACT WITH THE VICTIM. Use a nonconducting implement, such as, a dry rope or board, to free the victim from the live conductor. If the victim is unconscious, apply first aid and get immediate medical help.

- Never wear jewelry when working on this equipment. Jewelry can conduct electricity, resulting in electric shock, or may get caught in moving components, causing injury.

### **FIRE HAZARDS**

- For fire safety, the generator must be installed and maintained properly. Installation must always comply with NFPA 70 (latest edition), "National Electrical Code", Article 551, and NFPA 1192 (latest edition), "Standard for Recreational Vehicles", along with all applicable codes, standards, laws, and regulations. Adhere strictly to local, state, and federal electrical and building codes. Comply with regulations the Occupational Safety and Health Administration (OSHA) has established. Also, ensure that the generator is installed in accordance with the manufacturer's instructions and recommendations. After proper installation, do nothing that might alter the installation and render the unit in noncompliance with the aforementioned codes, standards, laws, and regulations.
- Keep a fire extinguisher in the vehicle at all times. Extinguishers rated "ABC" by the National Fire Protection Association are appropriate for use on the recreational vehicle generator electrical system. Keep the extinguisher properly charged and be familiar with its use. If there are any questions pertaining to fire extinguishers, consult the local fire department.

### **EXPLOSION HAZARDS**

- Do not smoke around the generator. Wipe off any fuel or oil spills immediately. Ensure that no combustible material is left in the generator compartment, or on or near the generator, as FIRE or EXPLOSION may result. Keep the area surrounding the generator clean and free of debris.
- All fuel types are potentially FLAMMABLE and/or EXPLOSIVE and should be handled with care. Comply with all laws regulating the storage and handling of fuels. Inspect the unit's fuel system frequently and correct any leaks immediately. Before placing this equipment into service, the fuel supply lines must be properly installed, purged, and leak-tested according to applicable fuel-gas codes.

## 1.1 GENERATOR IDENTIFICATION

Please record the following information from the generator DATA LABEL or information label, located below the user control panel.

- |                       |                        |
|-----------------------|------------------------|
| 1. Model Number _____ | 2. Serial Number _____ |
| 3. kW Rating _____    | 4. Rated Voltage _____ |
| 5. Phase _____        | 6. Hertz _____         |

### ✦ Model: 005432-0

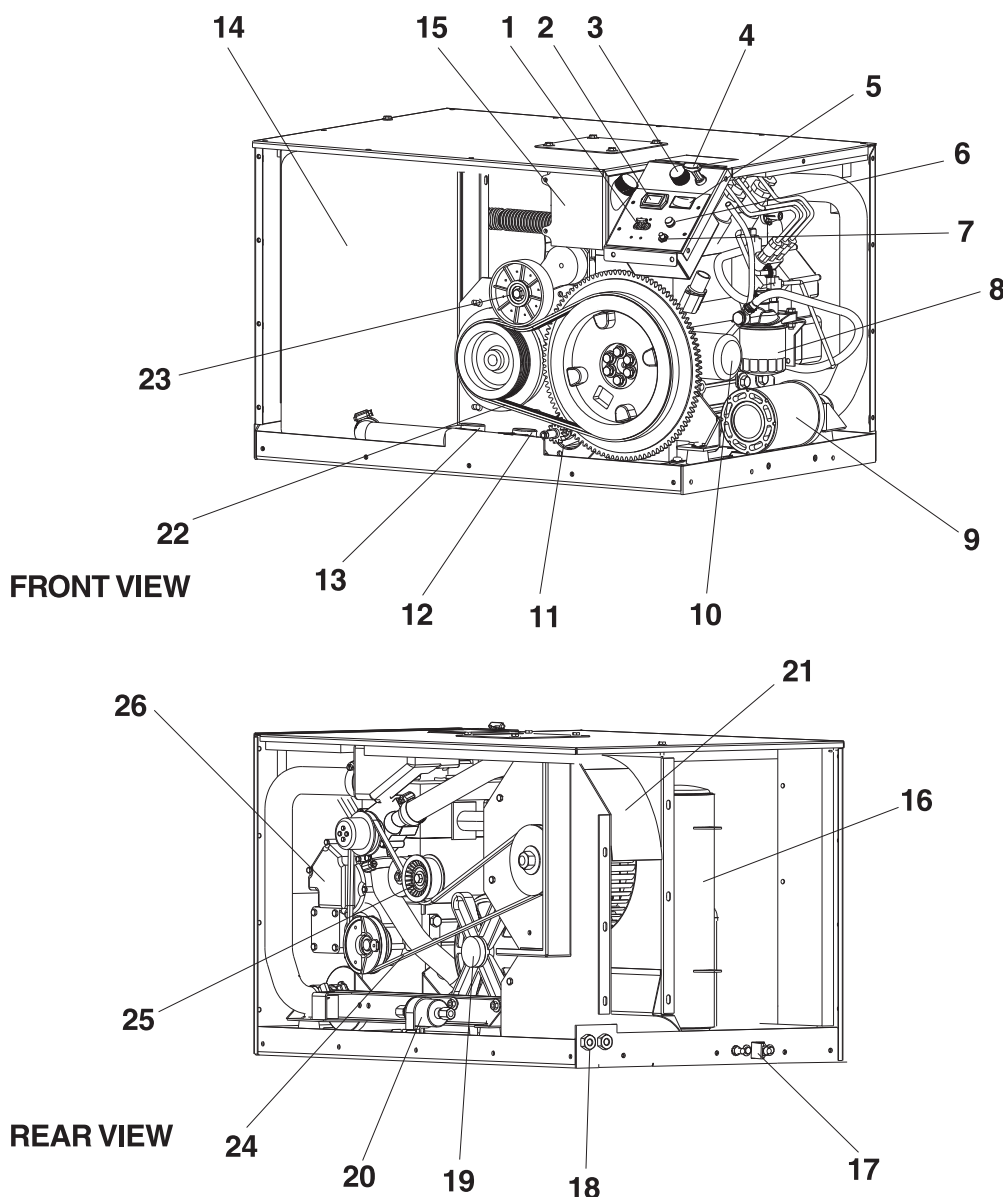

1. 2-Pole, 40-amp Circuit Breaker
2. Hourmeter
3. Oil Fill Opening and Plug
4. Oil Dipstick
5. Engine Start/Stop Switch
6. 15-amp Fuse
7. Engine Preheat Switch
8. Fuel Filter
9. Air Filter
10. Oil Filter
11. Starter Motor
12. Preheat Contactor
13. Starter Contactor
14. Radiator
15. Coolant Recovery Tank
16. Muffler
17. Battery Connections
18. Fuel Connections
19. Alternator
20. Fuel Pump
21. Centrifugal Cooling Fan and Housing
22. Alternator Drive Belt
23. Alternator Drive Belt Tensioner
24. Cooling Fan Drive Belt
25. Cooling Fan Drive Belt Tensioner
26. Engine

## 1.2 GENERATOR APPLICABILITY

These generators have been designed and manufactured for supplying electrical power to recreational vehicles. DO NOT modify the generator nor use it for any application other than for what it was designed. If there are any questions pertaining to its application, write or call the factory. Do not use the unit until advised by a competent authority.



▲ For fire safety, the generator must have been properly installed in compliance with NFPA 70 (latest edition), “National Electrical Code”, Article 551, and NFPA 1192 (latest edition), “Standard for Recreational Vehicles”. The generator also must have been installed in strict compliance with the manufacturer’s detailed installation instructions. After installation, do nothing that might render the unit in noncompliance with such codes, standards, and instructions.

Use this generator to supply electrical power for operating 120/240-volt, single-phase, 60-Hertz, AC electrical loads. These loads can require up to 8,500 watts (8.5 kW) of power, but cannot exceed 70.8 AC amps of current at 120 volts, or 35.4 AC amps at 240 volts.



▲ Do not overload the generator. Some installations may require that electrical loads be alternated to avoid overloading. Applying excessively high electrical loads may damage the generator and shorten its life. Add up the rated watts of all electrical lighting, appliance, tool, and motor loads the generator will power at one time. This total should not be greater than the wattage capacity of the generator. If an electrical device nameplate gives only volts and amps, multiply volts times amps to obtain watts (volts x amps = watts). Some electric motors require more watts of power (or amps of current) for starting than for continuous operation.

## 1.3 SAFETY

Before attempting to use the generator set, carefully read the “Safety Rules” section of this manual. Comply strictly with these rules to prevent accidents and damage to equipment and/or property. We suggest copying and posting the “Safety Rules” in potential hazard areas of the vehicle. Stress safety to all operators and potential operators of this equipment.

## 1.4 GENERATOR AC CONNECTION SYSTEM

This generator is equipped with dual-stator AC power windings. These two-stator windings supply electrical power to customer electrical loads by means of a dual, two-wire connection system. Note, however, that the neutral is grounded.

The generator may have been installed so that it powers 120-volt AC electrical loads only (Figure 1.1). It can be rewired to connect 120/240-volt AC electrical loads. This procedure should be done by an Authorized Service Dealer or other qualified installer. Refer to the installation portion of this manual for more information.

**Figure 1.1 – Connections for 120 Volts Only — Dual Circuits**

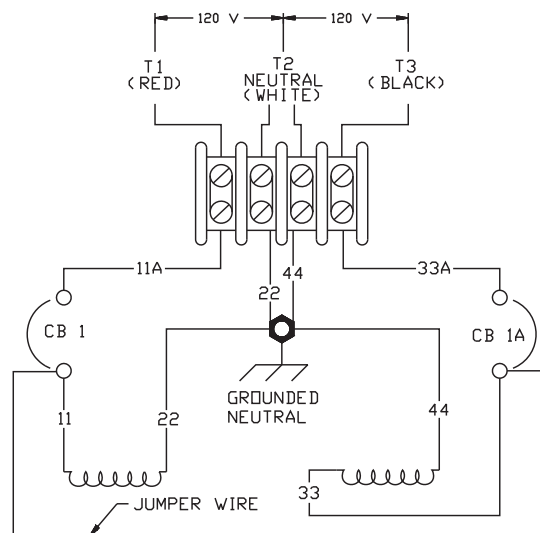

## 1.5 SPECIFICATIONS

### ◆ 1.5.1 FUEL REQUIREMENTS

The generator is equipped with a diesel fuel system. Use clean, fresh No. 1D or No. 2D diesel fuel with minimum Cetane number of 40. The diesel fuel must also conform to American Society of Testing and Materials (ASTM) specifications. Never use any dirty or contaminated fuel. When adding fuel, DO NOT overfill the tank. Allow room at the top of the tank for fuel expansion. Depending on the installation, the generator may have either a separate fuel tank or “share” the vehicle’s engine fuel tank.

**NOTE:**

Some installations using a “shared” fuel tank may have a generator fuel pickup tube that is shorter than the vehicle’s engine pickup tube. Such an arrangement causes the generator engine to “run out of fuel”, while adequate fuel for the vehicle engine remains in the tank.

Also, appropriate care should be taken in applications where extremely low ambient temperatures are possible, to ensure the temperature of the diesel fuel is not allowed to fall below levels where “gelling” could occur.

⚠ Ethylene glycol base antifreeze is poisonous. Do not use mouth to siphon coolant from the radiator, recovery bottle, or any container. Wash hands thoroughly after handling. Never store used antifreeze in an open container because animals are attracted to the smell and taste of antifreeze, even though it is poisonous to them.

— ⚠ CAUTION ⚠ —

⚠ Do not use any chromate base rust inhibitor with ethylene glycol base antifreeze; or else, chromium hydroxide (“green slime”) will form and cause overheating. Engines that have been operated with a chromate base rust inhibitor must be chemically cleaned before adding ethylene glycol base antifreeze. Using any high-silicate antifreeze boosters or additives will also cause overheating. **DO NOT** use any soluble oil inhibitor for this equipment.

**◆ 1.5.2 FUEL CONSUMPTION (GAL/HR)**

Model	No Load	Half Load	Full Load
005432-0	0.28	0.49	0.78

**◆ 1.5.3 ENGINE OIL REQUIREMENTS**

Use a high-quality detergent oil with American Petroleum Institute (API) classification “For Service CC.” Detergent oils keep the engine cleaner and reduce carbon deposits. Use oil having the following SAE viscosity rating, based on the ambient temperature range anticipated before the next oil change:

Temperature	Oil Grade (Recommended)
Above 100° F (38° C)	SAE 15W-40* or SAE 40
40° to 100° F (4.4° to 38° C)	SAE 10W-30 or SAE 30
Below 40° F (4.4° C)	SAE 5W-20 or 5W-30
<b>* - in units from the factory</b>	

Crankcase and oil filter capacity is approximately 4.35L or 4.6 U.S. quarts. Do NOT use special additives. See "Checking the Engine Oil Level" and "Changing the Engine Oil and/or Filter" sections for oil level checking and changing procedures.

**◆ 1.5.4 COOLANT**

Use a 50:50 mixture that is half low silicate, ethylene glycol base antifreeze and half soft water. Use only soft water and only low silicate antifreeze. If desired, a high-quality rust inhibitor to the recommended coolant mixture may be added. When adding coolant, always add the recommended 50-50 mixture.

— ⚠ **DANGER** ⚠ —

⚠ Do not remove the radiator pressure cap while the engine is hot; otherwise, serious burns from boiling liquid or steam could result.

**◆ 1.5.5 ENGINE**

Type of Engine.....	ISM Diesel
Cylinder Arrangement.....	3, in-line
Displacement.....	69.02 in <sup>3</sup> . (1131 cc)
Bore.....	3.03 in. (77 mm)
Stroke.....	3.18 in. (81 mm)
Compression Ratio .....	23.56-to-1
Combustion Chamber Type.....	Pre-Combustion
Rated Horsepower .....	15 @ 1,950 rpm
Cylinder Block .....	Cast Iron
Number of Main Bearings.....	4
Number of Teeth on Flywheel.....	104
Type of Governor .....	Mechanical, Fixed Speed
Fuel Filter .....	Full Flow Spin-On (Part # 69858)
Oil Filter .....	Full Flow with Bypass Valve (Part # 126-70939)
Oil Pressure.....	29-71 psi
Type of Cooling System.....	Pressurized, Closed Recovery
Cooling Method .....	Liquid-cooled
Type of Cooling Fan.....	Centrifugal Puller
Cooling System Capacity.....	1.4 U.S. gals (5.3 L)
Air Cleaner .....	Disposable Filter (Part # C4880)
Starter .....	12-volt DC Electric
Recommended Battery.....	70 Ah, 360 Cold-cranking Amps (Minimum ratings)
Maximum Cranking Current .....	220 Amps
Ground Polarity.....	Negative



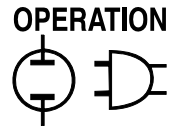

### ◆ 1.5.6 GENERATOR

Rated Maximum Continuous AC Output at ...

85° F (29° C) Ambient.....	8,500 Watts (8.5 kW)
100° F (38° C) Ambient.....	7,500 Watts (7.5 kW)
120° F (49° C) Ambient.....	6,000 Watts (6.0 kW)

Rated Voltage..... 120/240 Volts AC\*

Rated Maximum Continuous AC Current at ...

8,500 Watts	
120 Volts .....	70.8 Amps
240 Volts .....	35.4 Amps
7,500 Watts	
120 Volts .....	62.5 Amps
240 Volts .....	31.25 Amps
6,000 Watts	
120 Volts .....	50.0 Amps
240 Volts .....	25.0 Amps

Phase..... Single

Rotor Speed at No Load.....3,780 rpm

Number of Rotor Poles.....2

Engine RPM.....1,950

Rated AC Frequency..... 60 Hz

Battery Charge Voltage..... 14 Volts DC

Battery Charge Current..... 2 Amps (max)

Weight.....504 Pounds

Length..... 36.6 inches (929 mm)

Width..... 23.8 inches (604 mm)

Height..... 23.8 inches (604 mm)

\*All units are reconnectable to 240-volt only AC output.

## 2.1 GENERATOR CONTROL PANEL

The following features are mounted on the generator control panel (Figure 2.1):

Figure 2.1 – Generator Control Panel

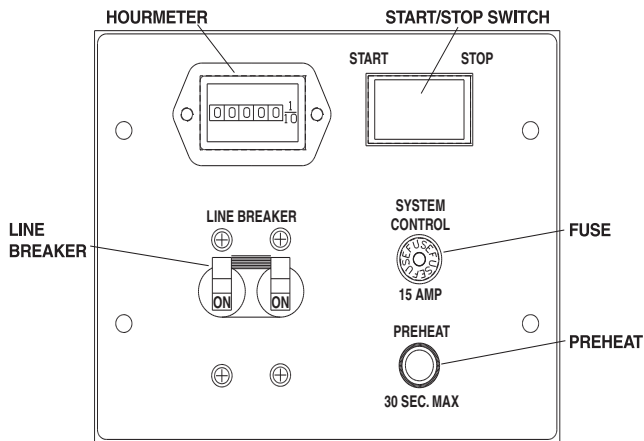

NOTE: PANEL SHOWN WITHOUT WEATHER-SEAL BOOTS.

### ◆ 2.1.1 HOURMETER

This indicates the length of time the engine/generator has operated, in hours and tenths of hours. Use the hourmeter to ensure that the periodic maintenance tasks for the generator are completed on a timely basis.

### ◆ 2.1.2 START/STOP SWITCH

To crank and start the engine, hold this switch in the START position. Release the switch when the engine starts. To stop an operating engine, press and hold the switch in the STOP position until the engine shuts off. The switch's center position is the RUN position.

### ◆ 2.1.3 FUSE

The 15-amp fuse protects the engine's DC control circuit against electrical overload. If the fuse element has melted open due to overloading, the engine cannot be cranked. If the fuse must be replaced, use only an identical replacement (i.e., AGC-15).



⚠ If a fuse element melts, find the cause of the overload before replacing the fuse.

### ◆ 2.1.4 LINE BREAKER

The line (i.e., main) breaker protects the generator's AC output circuit against overload and provides a method of turning OFF the generator's 120/240-volt AC output to the vehicle circuits. The generator has two 40-amp breakers.

NOTE:

Refer to section "Generator AC Connection System,". Individual installations will differ. If an overload occurs, the dual breakers will open the ungrounded (i.e., hot) stator leads (11 and 33 in Figure 1.1). When the generator has been connected for 120/240 dual voltage (Figure 2.16), the line breakers will operate on the ungrounded (i.e., hot) stator leads (11 and 44 in Figure 2.16).

### ◆ 2.1.5 PREHEAT SWITCH

The diesel engine is equipped with glow plugs, one for each cylinder. When the preheat switch is pressed, the glow plugs heat the engine combustion chamber, allowing for quicker starts when the engine is cold. Pressing the preheat switch also operates the fuel pump.

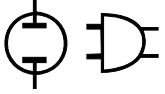

## 2.2 OPTIONAL REMOTE START/STOP

This generator is equipped with a plug-in connector that can be interfaced with an optional remote panel provided inside the vehicle. This option allows for starting and stopping the generator conveniently from within the vehicle. Refer to Part II - "Installation Instructions", for details on the remote start/stop option.

## 2.3 BEFORE STARTING THE ENGINE

### NOTE:

**Instructions and information in this manual assume the generator has been properly installed, connected, serviced, tested and adjusted by a qualified installation technician or installation contractor.**

### ◆ 2.3.1 INSTALLATION

Generator installation must have been properly completed so that it complies with all applicable codes, standards, and regulations and with the manufacturer's recommendations.

### NOTE:

**Be sure the installation complies with all standards and codes listed in the "Standards Booklets" section of this manual.**

### ◆ 2.3.2 ENGINE LUBRICATION

Before starting the engine, have the engine crankcase properly serviced with the recommended oil. Refer to the "Engine Oil Requirements", "Checking the Engine Oil Level" and "Changing the Engine Oil and/or Filter" sections for oil servicing procedures and recommendations.



⚠ Any attempt to crank or start the engine before it has been properly serviced with the recommended oil may result in an engine failure.

### ◆ 2.3.3 FUEL SUPPLY

The engine must have an adequate supply of proper fuel to operate. Before starting it, check that sufficient fuel is available.

### NOTE:

**Depending on the installation, the generator may have either a separate fuel tank or "share" the vehicle's engine fuel tank.**

**Some installations using a "shared" fuel tank may have a generator fuel pickup tube that is shorter than the vehicle's engine pickup tube. Such an arrangement causes the generator engine to "run out of fuel", while adequate fuel for the vehicle engine remains in the tank.**

### ◆ 2.3.4 COOLANT LEVEL

Check the engine coolant level prior to initial use and at recommended intervals. Refer to the "Coolant" and "Engine Coolant" sections for procedures and recommendations.

### ◆ 2.3.5 COOLING AND VENTILATING AIR

Air inlet and outlet openings in the generator compartment must be open and unobstructed for continued proper operation. Without sufficient cooling and ventilating airflow, the engine/generator may overheat, causing engine shutdown and damage to the generator.

### ◆ 2.3.6 ENGINE EXHAUST GAS

Before starting the generator engine, be sure there is no way for exhaust gases to enter the vehicle interior and endanger people or animals. Close windows, doors, and other openings in the vehicle that, if open, might permit exhaust gases to enter the vehicle.



⚠ The generator engine releases DEADLY carbon monoxide gas through its exhaust system. This dangerous gas, if breathed in sufficient concentrations, can cause unconsciousness or even death. Never operate the generator set with the vehicle inside any garage or other enclosed area. **DO NOT OPERATE THE GENERATOR IF THE EXHAUST SYSTEM IS LEAKING OR HAS BEEN DAMAGED. SYMPTOMS OF CARBON MONOXIDE POISONING ARE (a) inability to think coherently, (b) nausea, (c) vomiting, (d) twitching muscles, (e) throbbing temples, (f) dizziness, (g) headaches, (h) weakness, and (i) sleepiness. IF EXPERIENCING ANY OF THESE SYMPTOMS, MOVE INTO FRESH AIR IMMEDIATELY. IF SYMPTOMS PERSIST, GET MEDICAL HELP. Shut down the generator and do not operate it until it has been inspected and repaired.**

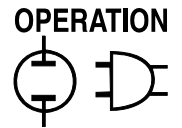

—▲ **DANGER** ▲—

▲ Never sleep in the vehicle while the genset is running unless the vehicle has a working carbon monoxide detector. The exhaust system must be installed in accordance with the genset installation manual. Make sure there is ample fresh air when operating the genset in a confined area.

## 2.4 STARTING THE GENERATOR

**NOTE:**

Read the vehicle manufacturer's instructions. The owner/operator should become familiar with the vehicle in which this generator is installed. Differences exist between vehicles. For example, some vehicles may use a transfer switch to isolate dockside power from the generator, while other vehicles may use an isolating receptacle. Some vehicles may be equipped with a DC converter, which allows the generator to power certain DC lighting and other DC loads.

To start the generator from either the generator control panel or from the optional remote panel, proceed as follows:

1. Turn OFF electrical loads using the means provided in the vehicle (such as, a main-line circuit breaker or transfer switch).

**NOTE:**

**If starting from the generator control panel, turn OFF loads by setting the generator's main-line breaker to the OFF (or open) position. If starting from a remote panel, turn OFF loads using the means provided in the vehicle (such as, a main circuit breaker). Electrical load circuits will be turned ON, after the generator has started, stabilized, and warmed up.**

2. If the engine is cold, press the Preheat switch for a maximum of 15 to 30 seconds.
3. While pressing the Preheat switch to crank the engine, hold the engine Start/Stop switch in the START position. When the engine starts, release the switches.

—▲ **CAUTION** ▲—

- ▲ If the engine does not start after it has been cranking for 15 seconds, release the Start/Stop switch, wait 15 seconds, and try again. Holding the switch for longer than 15 seconds can damage the starter motor.
4. Let the engine run at no-load for a few minutes to stabilize and warm up.
  5. Turn ON electrical loads, using the means provided in the vehicle (such as, a main-line circuit breaker or transfer switch).

## 2.5 STOPPING THE GENERATOR

1. Turn OFF all electrical loads, using the means provided in the vehicle (such as, a main-line circuit breaker or transfer switch).
2. Let the generator run at no-load for a few minutes, to stabilize internal engine generator temperatures.

—▲ **CAUTION** ▲—

- ▲ Do not stop the engine/generator immediately after running under load. This can overheat and damage the engine and/or generator.
3. Press and hold the Start/Stop switch in the STOP position, until the engine shuts off.

## 2.6 APPLYING LOADS TO GENERATOR

When applying electrical loads to the generator, observe these guidelines:

- Before applying electrical loads, let the generator stabilize and warm up for a minute or two.
- DO NOT overload the generator.

### ◆ 2.6.1 LETTING THE ENGINE STABILIZE

The generator supplies correctly rated voltage only at the proper governed speed. Some electrical appliances may be extremely sensitive to voltage. Incorrect voltages can damage such appliances.

Electrical loads applied on the engine at reduced operating speeds, such loads imposed on the engine, when sufficient power is not available, may shorten engine life. Never turn ON electrical loads until after the generator engine has started and stabilized at no-load.

### ◆ 2.6.2 DO NOT OVERLOAD THE GENERATOR

Read the rated wattage/ampere capacity of the generator on the generator data label located below the user control panel.

Applying electrical loads in excess of the unit's rated capacity may trip the line breaker or cause the engine/generator to shut down.

To avoid overloading, add up the wattage of all connected electrical lighting, appliance, tool, and motor loads. This total should not be greater than the generator's rated wattage capacity.

- Most lighting, appliance, tool, and motor loads indicate their required watts on their nameplate or data plate. For light bulbs, simply note the wattage rating of the bulb.
- If a load does not show its rated wattage, multiply that load's rated VOLTS times AMPS to obtain WATTS.

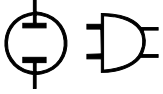

- Induction-type motors (such as, those that run the vehicle's furnace fan, refrigerator, air conditioner, etc.) need about 2-1/2 time more watts of power for starting than for running (for a few seconds during motor starting). Be sure to allow for this when connecting electrical loads to the generator. First, calculate the watts needed to start electric motors in the system. To that figure, add the running wattages of other items that will be operated by the generator.
- For the first two or three hours of operation, do not apply electrical loads over 75 percent of the unit's rating.

## 2.7 PROTECTION SYSTEMS

The engine has several safety switches that cause it to automatically shut down, under the following conditions: low oil pressure, high coolant temperature, and engine overspeed. See Figure 2.2 for the location of these devices. If automatic shutdown does occur, refer to "Troubleshooting Guide".

### ◆ 2.7.1 LOW OIL PRESSURE SWITCH

This switch is normally closed (N.C.) but is held open by engine oil pressure during engine running. Should operating oil pressure drop below approximately 10 psi, the switch contacts close, and the engine shuts down automatically.

### ◆ 2.7.2 HIGH COOLANT TEMPERATURE SWITCH

This normally-open (N.O.) thermostatic switch has a sensing tip that is immersed in captive coolant. Should the coolant temperature exceed approximately 115° C (240° F), the switch contacts close, and the engine shuts down automatically.

Figure 2.2 – Engine Protective Devices

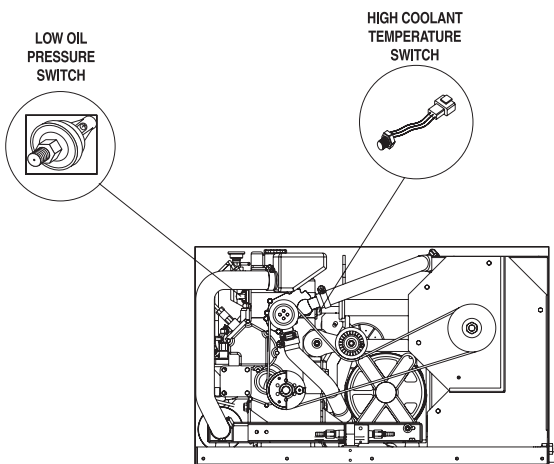

### ◆ 2.7.3 OVERSPEED SHUTDOWN

A DC control circuit board senses engine speed from the frequency of the alternator AC output. Should the alternator output frequency exceed approximately 72 Hertz (4,320 alternator rpm), circuit board action initiates an automatic engine shutdown.

### ◆ 2.7.4 OVERVOLTAGE PROTECTION

A solid-state voltage regulator (Figure 2.3) controls the generator's AC output voltage. This regulator supplies an excitation current to the rotor. By regulating the rotor's excitation current, the strength of its magnetic field is regulated and, in turn, the voltage delivered to connected electrical loads is controlled. When the AC frequency is 60 Hertz, voltage is regulated at 120 volts (voltage-to-frequency ratio is 2-to-1).

Figure 2.3 – Solid-state Voltage Regulator

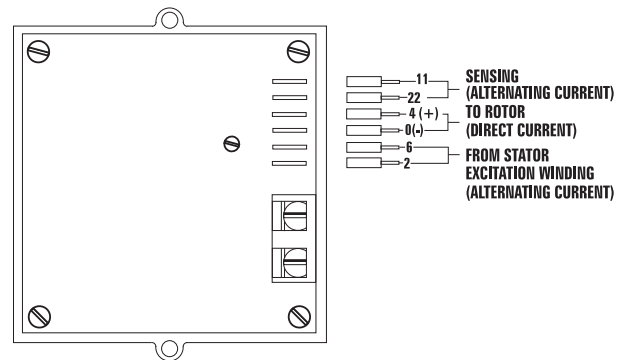

The voltage regulator also incorporates a "voltage surge protection circuit." This circuit prevents troublesome surges in the generator AC output voltage. Voltage surge is a common cause of damage to electronic equipment.

## 2.8 ADDITIONAL INFORMATION

### ◆ 2.8.1 ATTENTION REQUIRED AFTER SUBMERSION

If the recreational vehicle generator has been submerged in water, it **MUST NOT** be started and operated. Following any submersion in water, have an Authorized Service Dealer thoroughly clean and dry the generator.

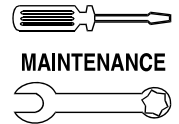

### ◆ 2.8.2 OPERATION IN HIGH GRASS OR BRUSH

Never operate the generator while the vehicle is parked over high grass, weeds, brush, leaves, or other combustible substance. Such materials can ignite and burn from the heat of the exhaust system. The generator exhaust system becomes extremely hot during operation and remains hot for a long time after it has shut down.

### ◆ 2.8.3 EFFECTS OF MOISTURE AND DIRT

Keep the generator set as clean and dry as possible. Protect the unit against excessive dust, dirt, corrosive vapors, road splash, etc. Permitting dirt and moisture to accumulate on generator windings will have an adverse effect on the insulation resistance of those windings.

When moisture is allowed to remain in contact with windings, some of the moisture will be retained in voids and cracks in the insulation. This reduces insulation resistance and will eventually cause problems. Dirt will make the problem worse, since it tends to hold moisture in contact with windings. Salt (as from sea air) will also worsen the problem, since it tends to absorb moisture from the air. Salt and moisture, when combined, form a good electrical conductor.

## 3.1 CHECKING THE ENGINE OIL LEVEL

Check the engine crankcase oil level every eight hours of operation, or at least once daily, before using the generator. For oil capacities and requirements, see "Engine Oil Requirements". To check the engine oil level, proceed as follows (see Figure 3.1):

1. Be sure the generator is as leveled as possible.
2. Remove the dipstick, and wipe it dry with a clean, lint-free cloth.
3. Install the dipstick, and fully seat the T-handle; then, remove it again. The oil level should be at the dipstick "Full" mark.
4. If necessary, remove the oil fill plug and slowly add oil until it reaches the dipstick "FULL" mark. DO NOT FILL ABOVE THE "FULL" MARK.



⚠ **Never operate the engine with the oil level below the "ADD" mark on the dipstick. Doing this could damage the engine.**

5. Install the oil-fill plug and the dipstick before operating the engine.

Figure 3.1 – Oil Maintenance Features

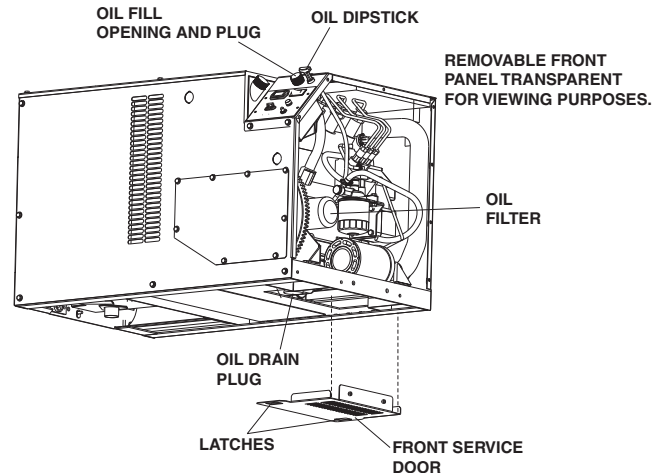

## 3.2 CHANGING THE ENGINE OIL AND/OR OIL FILTER



⚠ **Never operate the engine with the oil level below the "ADD" mark on the dipstick. Doing this could damage the engine.**

Change the engine oil and oil filter after the first 25 hours of operation. See the "Service Schedule" section for subsequent oil and filter changes. Change the oil more frequently, if operating consistently under heavy load or at high ambient temperatures.

To change the oil and/or oil filter, proceed as follows (see Figure 3.1):

1. Run the engine until it is thoroughly warmed up (for at least five minutes) then shut OFF the engine.
2. Immediately after the engine shuts OFF, remove the front service door, located beneath the unit, by retracting the two latches and pivoting the door downward. If space allows, remove the front panel by removing the four retaining bolts. Be careful not to let the panel fall.
3. Remove the air filter (see "Servicing the Engine Air Filter").
4. Remove the oil-drain plug and drain the oil into a suitable container. Removing the oil-fill plug will allow the crankcase to drain faster.
5. After the oil has drained, replace the oil-drain plug. Go to step 9 if changing oil only.
6. With the oil drained, remove the old oil filter by turning it counterclockwise.
7. Apply a light coating of clean engine oil to the gasket of the new filter.

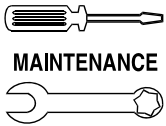

MAINTENANCE

## Section 3 – Maintenance

### Recreational Vehicle Generator

8. Screw the new filter on by hand, until its gasket lightly contacts the oil filter adapter. Then, tighten the filter an additional  $\frac{3}{4}$  to one turn.
9. Remove the dipstick, and wipe it dry with a clean, lint-free cloth. This will be used later to check the oil level.
10. Remove the oil-fill plug, and slowly add the proper type and amount of recommended oil (see "Engine Oil Requirements"). Periodically use the dipstick to check the oil level and continue to fill the crankcase until the oil reaches the dipstick "FULL" mark. **DO NOT FILL ABOVE THE "FULL" MARK.**
11. Install the oil-fill plug and the dipstick.
12. Reinstall the air filter.
13. Reattach the front service door or front panel; make sure the latches are fully engaged and the bolts are fully tightened.
14. Start the engine, and check for leaks.

#### NOTE:

**Check the oil level and fill to the "FULL" mark, after checking for leaks. The filter will retain some oil.**

## 3.3 SERVICING THE ENGINE

### AIR FILTER

To access the engine air filter (Figure 3.2), remove the front service door, located beneath the unit, by retracting the two latches and pivoting the door downward. Loosen the hose clamp at the base of the air filter and remove the filter. Place the hose clamp on the new filter and install it, making sure it is positioned properly before reattaching the service door. Make sure the service door latches are fully engaged.

Figure 3.2 – Engine Air Filter

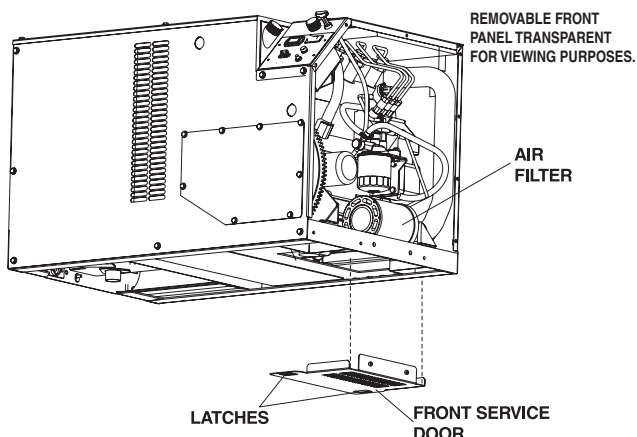

See the "Service Schedule" for recommended air cleaner maintenance.

## 3.4 SPARK ARRESTOR MUFFLER

The exhaust muffler supplied with the generator is a spark arrestor type. The exhaust mufflers for recreational vehicle generators do not have a spark arrestor screen, but are of the more efficient "toroid" or "swirl" type. To remove carbon and combustion deposits from the muffler, proceed as follows (see Figure 3.3):

1. Place the unit above a noncombustible surface, and ensure that the generator exhaust piping is cool.
2. Remove the two screws holding the spark arrestor access plate to the rear floor pan.
3. Remove the spark arrestor access plate and gasket.
4. Remove the hex pipe cap from the end of the spark arrestor cleanout pipe.
5. Thread on a  $\frac{3}{8}$ " NPT pipe coupling and pipe nipple to extend the cleanout pipe at least 10 inches (250 mm) below the rear floor pan; additional piping may be added to direct the muffler exhaust away from the cooling air discharge flow beneath the unit.

Figure 3.3 – Spark Arrestor Muffler Maintenance

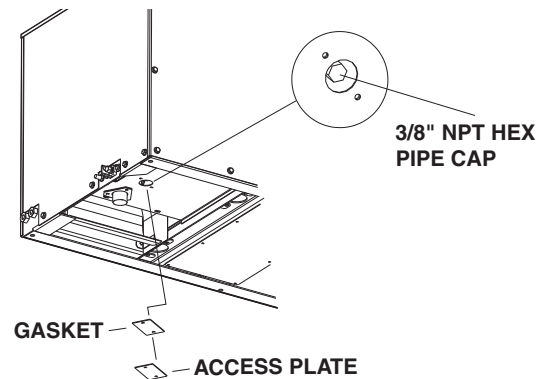

6. Start and run the engine for approximately 15 minutes.
7. Shut down the engine, and allow the piping to cool.
8. Remove the  $\frac{3}{8}$ " NPT coupling and piping.
9. Apply a graphite-base, anti-seize compound to the cleanout pipe threads.
10. Reinstall the hex pipe cap, spark arrestor access plate, gasket, and two screws.

#### WARNING

The exhaust system of this product gets extremely hot and remains hot after shutdown. High grass, weeds, brush, leaves, etc., must remain clear of the exhaust. Such materials may ignite and burn from the heat of the exhaust system.

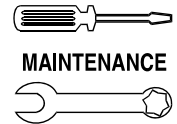

—▲ WARNING ▲—

▲ Failure to provide and maintain a spark arrestor may be in violation of the law. If this generator is used on any forest-covered, brush-covered, or grass-covered unimproved land, the vehicle owner or operator must maintain the spark arrestor in good condition. In the state of California, the preceding is required by law (Section 4442 of the California Public Resources Code). Other states may have similar laws. Federal laws apply on federal lands.

—▲ WARNING ▲—

▲ Be sure to reinstall the hex pipe cap tightly to the spark arrestor cleanout pipe. Vibration could cause a loose cap to fall out, resulting in hot engine exhaust being drawn through the centrifugal cooling fan and out beneath the unit. This could result in damage to the generator or in discharge of hot exhaust sparks beneath the unit.

### 3.5 CLEANING THE GENERATOR

Keep the generator as clean and as dry as possible. Dirt and moisture that accumulate on internal generator windings have adversely affect insulation resistance.

Periodically, clean the generator's exterior surfaces. A soft brush may be used to loosen caked-on dirt. Use a vacuum system or dry, low-pressure air to remove any accumulations of dirt. The generator is housed inside an all-weather enclosure; clean the enclosure with a soft, damp cloth or with sponge and water.

Once each year, have the generator cleaned and inspected by an Authorized Service Dealer. Service technicians will use dry, low-pressure air to clean internal windings. Parts inside the control console should be cleaned and inspected at this time, as well.

Finally, have the insulation resistance of stator and rotor windings checked. If insulation resistances are excessively low, the generator may require drying.

—▲ CAUTION ▲—

▲ Do NOT use a forceful spray of water to clean the generator. Water will enter the generator interior and cause problems, and may also contaminate the generator fuel system.

### 3.6 BATTERY MAINTENANCE

All lead-acid batteries will discharge when not in use. The generator battery should be inspected per the "Service Schedule". The following procedure should be used for inspection:

- Inspect the battery posts and cables for tightness and corrosion. Tighten and clean as necessary.
- Check the battery fluid level of unsealed batteries and, if necessary, fill with Distilled Water Only. Do not use tap water in batteries.
- Have the state of charge and condition checked by an Authorized Service Dealer.

**NOTE:**

**Servicing of the battery is to be performed or supervised by knowledgeable personnel, according to the required precautions. Keep unauthorized personnel away from batteries.**

**Damage will result if the battery connections are made in reverse.**

—▲ DANGER ▲—

▲ Do not dispose of the battery in a fire. The battery is capable of exploding. Storage batteries release explosive hydrogen gas. This gas can form an explosive mixture around the battery for several hours after charging. The slightest spark can ignite the gas and cause an explosion. Such an explosion can shatter the battery and cause blindness or other injury. Any area that houses a storage battery must be properly ventilated. Do not allow smoking, open flame, sparks, or any spark-producing tool or equipment near the battery. Discharge static electricity from body before touching the battery by first touching a grounded metal surface.

▲ A battery presents a risk of electrical shock and high short-circuit current. The following precautions are to be observed when working on batteries:

- Remove watches, rings, and other metal objects;
- Use tools with insulated handles;
- Wear rubber gloves and boots;
- Do not lay tools or metal parts on top of the battery;
- Disconnect any charging source prior to connecting, or disconnecting, battery terminals; and
- Do not use any jumper cables or booster battery to crank and start the generator engine. If any battery has discharged, remove it for recharging.

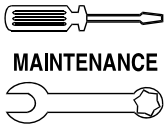

MAINTENANCE

## Section 3 – Maintenance

### Recreational Vehicle Generator

#### ⚠ WARNING ⚠

- ⚠ Do not open or mutilate the battery. Released electrolyte has been known to be harmful to the skin and eyes, and to be toxic.
- ⚠ The electrolyte is a dilute sulfuric acid that is harmful to the skin and eyes. It is electrically conductive and corrosive. The following procedures are to be observed:
  - Wear full eye protection and protective clothing;
  - Immediately wash with water all skin areas that come into contact with the electrolyte.
  - If the electrolyte contacts the eyes, immediately flush eyes thoroughly with water, and seek medical attention.
  - Spilled electrolyte is to be washed down with an acid-neutralizing agent. A common practice is to use a solution of 1 pound (500 grams) bicarbonate of soda to 1 gallon (4 liters) of water. The bicarbonate of soda solution is to be added until the evidence of reaction (foaming) has ceased. The resulting liquid is to be flushed with water and the area dried.

### 3.7 COOLING SYSTEM

Air intake and outlet openings in the generator compartment must be open and unobstructed for continued proper operation. Avoid obstructions, such as, high grass, weeds, brush, leaves, and snow.

Without sufficient cooling and ventilating air flow, the engine/generator quickly overheats, which causes it to shut down.

### 3.8 ENGINE COOLANT

Check the coolant level in the coolant recovery tank at least once daily or prior to use. Add the recommended coolant mixture (see "Coolant"), as necessary; the tank should be kept within the levels indicated on the adjacent decal. If desired, a high-quality rust inhibitor to the recommended 50-50 coolant mixture may be added. If added consistently, the recommended mixture will protect the unit against freezing temperatures.

Periodically remove the radiator pressure cap, located behind the access cover above the user control panel, to make sure the coolant recovery system is functioning properly. Coolant should be at the bottom of the radiator filler neck. If the coolant level is low, inspect the gasket in the radiator pressure cap. Replace the cap, if necessary. To have the pressure cap tested, contact an Authorized Service Dealer. Inspect both the cooling system and coolant recovery system for leaks.

#### ⚠ DANGER ⚠

- ⚠ Do not remove the radiator pressure cap while the engine is hot; otherwise, serious burns from boiling liquid or steam could result.
- ⚠ Ethylene glycol base antifreeze is poisonous. Do not use mouth to siphon coolant from the radiator, recovery bottle, or any container. Wash hands thoroughly after handling. Never store used antifreeze in an open container because animals are attracted to the smell and taste of antifreeze, even though it is poisonous to them.

#### ⚠ CAUTION ⚠

- ⚠ Do not use any chromate base rust inhibitor with ethylene glycol base antifreeze; otherwise, chromium hydroxide ("green slime") will form and cause overheating. Engines that have been operated with a chromate base rust inhibitor must be chemically cleaned before adding ethylene glycol base antifreeze. Using any high-silicate antifreeze boosters or additives will also cause overheating. DO NOT use any soluble oil inhibitor for this equipment.

### 3.9 MAJOR SERVICE MANUAL

To obtain a service manual for the generator, the nearest Authorized Service Dealer. Make sure to identify the MODEL NUMBER and SERIES.

### 3.10 DRIVE BELT

The engine drives the generator rotor by means of a pulley and drive belt arrangement. Drive belt tension was properly adjusted before the unit was shipped from the factory. If suspect that drive belt tension is incorrect, contact an Authorized Service Dealer.

### 3.11 EXERCISING THE GENERATOR

At least once every seven days, start and operate the generator. Let the unit run for at least 30 minutes to "exercise" the engine. If the generator cannot be exercised every seven days, and it is to be out of service longer than 30 days, see "Out-of-Service Procedure".



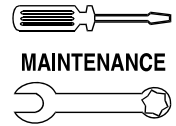

## 3.12 OUT-OF-SERVICE PROCEDURE

### ◆ 3.12.1 REMOVAL FROM SERVICE

Prepare the generator for storage as follows:

1. Start the engine and let it run until it is thoroughly warmed up (at least five minutes), then shut off the engine.
2. While the engine is still warm from running, drain the oil completely (see "Changing the Engine Oil and/or Filter"). Refill the crankcase with the recommended oil (see "Engine Oil Requirements").
3. Attach a tag to the engine, indicating the viscosity and classification of the oil in the crankcase.
4. Remove the battery and store it in a cool, dry room on a wooden board. Never store the battery on any concrete or earthen floor.
5. Clean and wipe the entire generator.

### ◆ 3.12.2 RETURN TO SERVICE

To return the unit to service after storage, proceed as follows:

1. Check the tag on the engine for oil viscosity and classification. Verify that the correct recommended oil is used in the engine (see "Engine Oil Requirements"). If necessary, drain and refill with the proper oil.
2. Check the state of the battery. Fill all cells of unsealed batteries to the proper level with distilled water. **DO NOT USE TAP WATER IN THE BATTERY.** Recharge the battery to 100 percent state of charge, or, if defective, replace the battery.
3. Clean and wipe the entire generator.
4. Reconnect the battery. Observe battery polarity. Damage may occur if the battery is connected incorrectly.
5. Turn OFF all electrical loads. Add fuel, if necessary, and then start the engine.
6. Allow the unit to warm up thoroughly.
7. Apply electrical loads to at least 50 percent of the unit's rated wattage capacity.
8. When the engine is thoroughly warmed up, shut it down.
9. The generator is now ready for service.

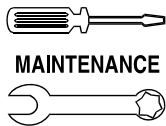

**Section 3 – Maintenance**  
**Recreational Vehicle Generator**

**3.13 SERVICE SCHEDULE**

**ATTENTION: It is recommended that all service work be performed by the nearest Authorized Service Dealer.**

SYSTEM/COMPONENT	PROCEDURE			FREQUENCY
	Inspect	Change	Clean	
X = Action R = Replace/Adjust as Needed * = To Be Completed by an Authorized Service Dealer.				D = Daily      W = Weekly M = Monthly    Y = Yearly H = Hours
<b>FUEL</b>				
Fuel level	X			AFTER 25-H, D / BEFORE USE
Fuel lines and connections*	X			AFTER 25-H, EVERY 250 H / 6 M
Fuel Filter*		X		EVERY 250 H / 6 M
<b>LUBRICATION</b>				
Oil level	X			EVERY 8 H / D
Oil		X		AFTER 25-H, EVERY 250 H / 6 M
Oil Filter		X		AFTER 25-H, EVERY 250 H / 6 M
Oil line leakage*	X			EVERY 100 H
<b>COOLING</b>				
Engine cooling system*	X			AFTER 25-H, EVERY 100 H / M
Coolant level	X			AFTER 25-H, D / BEFORE USE
Coolant*		X		EVERY 500 H / Y
Enclosure louvers	X		X	EVERY 250 H / 6 M
<b>EXHAUST</b>				
Exhaust system	X			EVERY 100 H / M
Retorque Exhaust Manifold*	X			EVERY 750 H
Clean out Muffler/Spark Arrestor			X	EVERY 150 H/Y
<b>BATTERY</b>				
Electrolyte fluid level	X			AFTER 25-H, W
Charge and condition	X	R	X	W, EVERY 250 H / 6 M
<b>FAN/ALTERNATOR BELTS</b>				
Tension and condition*	X	R		EVERY 750 H
<b>ENGINE</b>				
Retorque cylinder head*	X			EVERY 750 H
Retorque intake manifold*	X			EVERY 750 H
Starter motor*	X			EVERY 750 H
Air filter	X	R		EVERY 500 H
Compression*	X			EVERY 750 H
Valve clearance*	X	R		EVERY 750 H
Governor*	X	R		EVERY 750 H
Safety devices*	X	R		EVERY 750 H
Injection system*	X	R		EVERY 750 H
<b>GENERAL</b>				
Overall condition	X		X	AFTER 25-H, W
Exercise system				W
<b>COMPLETE TUNE-UP*</b>	X	X	X	Y

# **PART II – INSTALLATION INSTRUCTIONS**

—▲ **DANGER** ▲—

**ONLY QUALIFIED ELECTRICIANS OR CONTRACTORS  
SHOULD ATTEMPT INSTALLATION!**



**⚠ DANGER:** For fire safety, installation of a generator into a recreational vehicle must comply strictly with NFPA 70 (latest edition), “National Electrical Code”, Article 551, and NFPA 1192 (latest edition), “Standard for Recreational Vehicles”. In addition, installation must comply with the manufacturer’s instructions and recommendations. **⚠**

## NOTICE TO INSTALLER

These *Installation Instructions* have been published by The manufacturer to aid in the installation of the products described in this manual. The manufacturer assumes that installation personnel are familiar with the procedures for installing such products, or similar products manufactured. The manufacturer also assumes that personnel have been trained in the recommended installation procedures for these products and that such training includes (a) use of common hand tools, (b) use of special tools, and (c) use of any tools and/or equipment from other suppliers.

The manufacturer cannot possibly know of, nor advise the recreational vehicle trade of, all conceivable methods, procedures, or techniques by which to perform an installation. Nor can the manufacturer anticipate every possible hazard that might result from each installation method, procedure, or technique. The manufacturer has not undertaken any such wide evaluation. Therefore, people who use a method, procedure, or technique that the manufacturer does not specifically recommend must first completely satisfy themselves that their safety, the safety of the vehicle's occupants, and the product's safety are not endangered by the method, procedure, or technique selected.

Information, illustrations, specifications, etc., contained in these *Installation Instructions* are based on the latest information available at the time of publication. Every effort has been expended to be sure that such data are both accurate and current. However, the manufacturer reserves the right to change, alter, or otherwise improve this product at any time, without prior notice.

### ⚠ **DANGER** ⚠

**⚠** Despite the safe design of this generator, operating this equipment imprudently, neglecting its maintenance, or being careless can cause possible injury or death. Permit only responsible and capable persons to operate or maintain this equipment.

**⚠** Parts of the generator are rotating and/or hot during operation. Exercise care near running generators.

**⚠** Potentially lethal voltages are generated by these machines. Ensure all steps are taken to render the machine safe before attempting to work on the generator.

## ⚠ **GENERAL HAZARDS** ⚠

- For safety reasons, the manufacturer recommends that the installation, initial startup, and maintenance of this equipment is carried out by an Authorized Service Dealer.
- The engine exhaust fumes contain carbon monoxide, which can be DEADLY. This dangerous gas, if breathed in sufficient concentrations, can cause unconsciousness or even death. This exhaust system must be installed properly, in strict compliance with applicable codes and standards. Following installation, do nothing that might render the system unsafe or in noncompliance with such codes and standards. The generator compartment must be completely vapor-sealed from the vehicle interior. There must be no possibility of exhaust fumes entering the vehicle interior. Never operate this equipment with a leaking or defective exhaust system.
- Keep hands, feet, clothing, etc., away from drive belts, fans, and other moving or hot parts. Never remove any drive belt or fan guard while the unit is operating.
- Adequate, unobstructed flow of cooling and ventilating air is critical to correct generator operation and is required to expel toxic fumes and fuel vapors from the generator compartment. Without sufficient cooling airflow, the engine/generator quickly overheats, which causes serious damage to the generator. Do not alter the installation or permit even partial blockage of ventilation provisions, as this can seriously affect safe operation of the generator.
- When working on this equipment, remain alert at all times. Never work on the equipment when physically or mentally fatigued.
- Before performing any maintenance on the generator, disconnect its battery cables to prevent accidental startup. First, disconnect the cable from the battery post, indicated by a NEGATIVE, NEG, or (-). Reconnect that cable last.
- Never use the generator or any of its parts as a step. Stepping on the unit can stress and break parts, and may result in dangerous operating conditions from leaking exhaust gases, fuel leakage, oil leakage, etc.
- Never insert any tool or other object through openings in the generator interior, even if the unit is not running. Serious injury or damage to the equipment could be done.



## **ELECTRICAL HAZARDS**

- The generator covered by this manual produces dangerous electrical voltages that can cause fatal electrical shock. Avoid contact with bare wires, terminals, connections, etc., while the unit is running. Ensure all appropriate covers, guards, and barriers are in place before operating the generator. If work must be done around an operating unit, stand on an insulated, dry surface to reduce shock hazard.
- Do not handle any kind of electrical device while standing in water, while barefoot, or while hands or feet are wet. **DANGEROUS ELECTRICAL SHOCK MAY RESULT.**
- During installation onto the vehicle, properly ground (bond) the generator either by solid mounting to the vehicle frame or chassis, or by means of an approved bonding conductor. **DO NOT** connect the bonding conductor to any generator part that might be removed or disassembled during routine maintenance. If the grounding conductor must be replaced, use only a flexible conductor that is of No. 8 American Wire Gauge (AWG) copper wire minimum.
- If the vehicle electrical circuits can be powered by any other source of electricity (such as, a “dockside” power receptacle), there must be no possibility of connecting the different power sources to the vehicle’s circuits at the same time. The dockside (utility) power source must be positively isolated from the vehicle’s circuits whenever the generator is operating. Failure to isolate the vehicle’s circuits from the dockside power supply when the generator is running may result in damage to the generator or in serious injury or death to dockside (utility) power workers due to backfeed of electrical energy.
- In case of an accident caused by electric shock, immediately shut down the source of electrical power. If this is not possible, attempt to free the victim from the live conductor. **AVOID DIRECT CONTACT WITH THE VICTIM.** Use a nonconducting implement, such as, a rope or board, to free the victim from the live conductor. If the victim is unconscious, apply first aid, and get immediate medical help.
- Never wear jewelry when working on this equipment. Jewelry can conduct electricity, resulting in electric shock, or may get caught in moving components, causing injury.

## **FIRE HAZARDS**

- For fire safety, the generator must be installed and maintained properly. Installation always must comply with applicable codes, standards, laws, and regulations. Adhere strictly to local, state and national electrical and building codes. Comply with regulations the Occupational Safety and Health Administration (OSHA) has established. Also, ensure that the generator is installed in accordance with the manufacturer’s instructions and recommendations. Following proper installation, do nothing that might alter a safe installation and render the unit in noncompliance with the aforementioned codes, standards, laws, and regulations.
- Keep a fire extinguisher in the vehicle at all times. Extinguishers rated “ABC” by the National Fire Protection Association are appropriate for use on the recreational vehicle generator electrical system. Keep the extinguisher properly charged, and be familiar with its use. If there are any questions pertaining to fire extinguishers, consult the local fire department.

## **EXPLOSION HAZARDS**

- Do not smoke around the generator. Wipe up any fuel or oil spills immediately. Ensure that no combustible materials are left in the generator compartment, or on or near the generator, as **FIRE** or **EXPLOSION** may result. Keep the area surrounding the generator clean and free from debris.
- All fuel types are potentially **FLAMMABLE** and/or **EXPLOSIVE** and should be handled with care. Comply with all laws regulating the storage and handling of fuels.
- Fuel supply lines must be properly installed, purged and leak-tested according to applicable fuel-gas codes, before placing this equipment into service. There must be no possibility of fuel vapors entering the vehicle interior.
- It is required that an approved, flexible, nonconductive fuel line between the generator fuel connection point and the rigid fuel lines be installed.

## 1.1 PURPOSE AND SCOPE OF THE MANUAL

These *Installation Instructions* have been prepared especially for the purpose of familiarizing installers and owners of the applicable equipment with the product's installation requirements. Give serious consideration to all information and instructions in the manual, both for safety and for continued reliable operation of the equipment.

Because of the different recreational vehicle models and the variations between the models, it would be extremely difficult, if not impractical, to provide detailed instructions for every possible installation. For that reason, instructions and illustrations in this manual are general in nature. Illustrations are not intended to serve as detailed installation blueprints.

The installation should comply strictly with all applicable codes, standards, and regulations pertaining to the installation and use of this product. If any portion of this manual appears to be in conflict with such codes, standards, or regulations, the applicable codes, standards, or regulations must take precedence over the manual.

## 1.2 SAFETY

Before handling, installing, operating, or servicing this equipment, carefully read the "Notice to Installer" and "Safety Rules" on pages 18 and 19. Comply with all safety rules to prevent death, personal injury, or damage to equipment and/or property. Stress safety to all installers, operators, and service technicians who work on this equipment.

## 1.3 STANDARDS BOOKLETS

Installation, use, and servicing of this equipment should comply strictly with published standards, as well as the manufacturer's recommendations. The following standards booklets (latest revision) are available from the sources indicated:

1. NFPA 1192, "Standard for Recreational Vehicles" (replaces ANSI A119.2/NFPA 501C), available from the National Fire Protection Association, Batterymarch Park, Quincy, MA 02269.
2. NFPA 70, "NFPA Handbook of the National Electric Code," available same as Item 1.
3. ANSI/RVIA EGS-1, "Engine Generator Sets for Recreational Vehicle Safety Requirements", available from the Recreational Vehicle Industry Association, 1896 Preston White Drive, Reston, VA 22090.
4. California Administrative Code, Title 25, available from the State of California, Documents Section, P.O. Box 1015, North Highlands, CA 95660.

5. CSA Electrical Bulletin 946, available from the Canadian Standards Association, Housing and Constructions Materials Section, 178 Rexdale Boulevard, Rexdale, Ontario, Canada, M9W 1R3.

## 1.4 EQUIPMENT DESCRIPTION

Instructions and information in this section pertain to liquid-cooled generators, designed specifically for installing in recreational vehicles. This unit operates 120/240-volt, single-phase, 60-Hertz, AC electrical loads that require up to 70.8 amps at 120 volts or 35.4 amps at 240 volts.

## 1.5 GENERATOR ENGINE OPERATING SPEED

The generator's two-pole revolving field (rotor) is driven by a three-cylinder, 1.1-liter diesel engine. The generator supplies 120/240 volts AC at 60 Hertz, when the rotor is operating at 3,600 rpm. Engine speed is held nearly constant by a mechanical, fixed speed governor at 1,950 rpm.

## 1.6 GENERATOR AC CONNECTION SYSTEM

The generator is equipped with dual stator power windings, as shown in Figure 1.1.

Figure 1.1 – Connections for 120 Volts Only — Dual Circuits

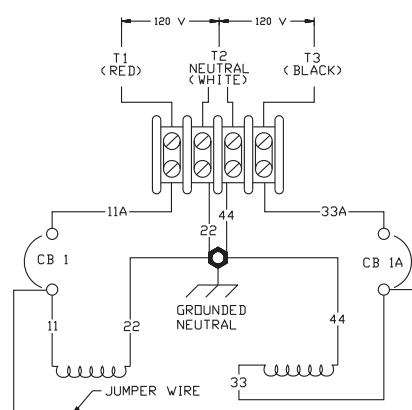

- The AC connection system uses a GROUNDED neutral. A separate green ground wire is connected to the recreational vehicle's junction box.
- For this unit, each stator winding can support 120-volt, 60-Hertz, AC electrical output (3,600 rpm). When the two stator windings are connected in series, the unit can generate an output of 240 volts AC.

**NOTE:**

**Do NOT connect loads in excess of circuit breaker ratings.**

**Section 1 – General Information**

**Recreational Vehicle Generator**

**Major Features and Dimensions – Drawing No. 0G6806-A**

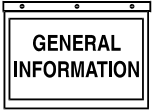

**Figure 1.2 – Major Features and Dimensions (Drawing 0G6806-A)**

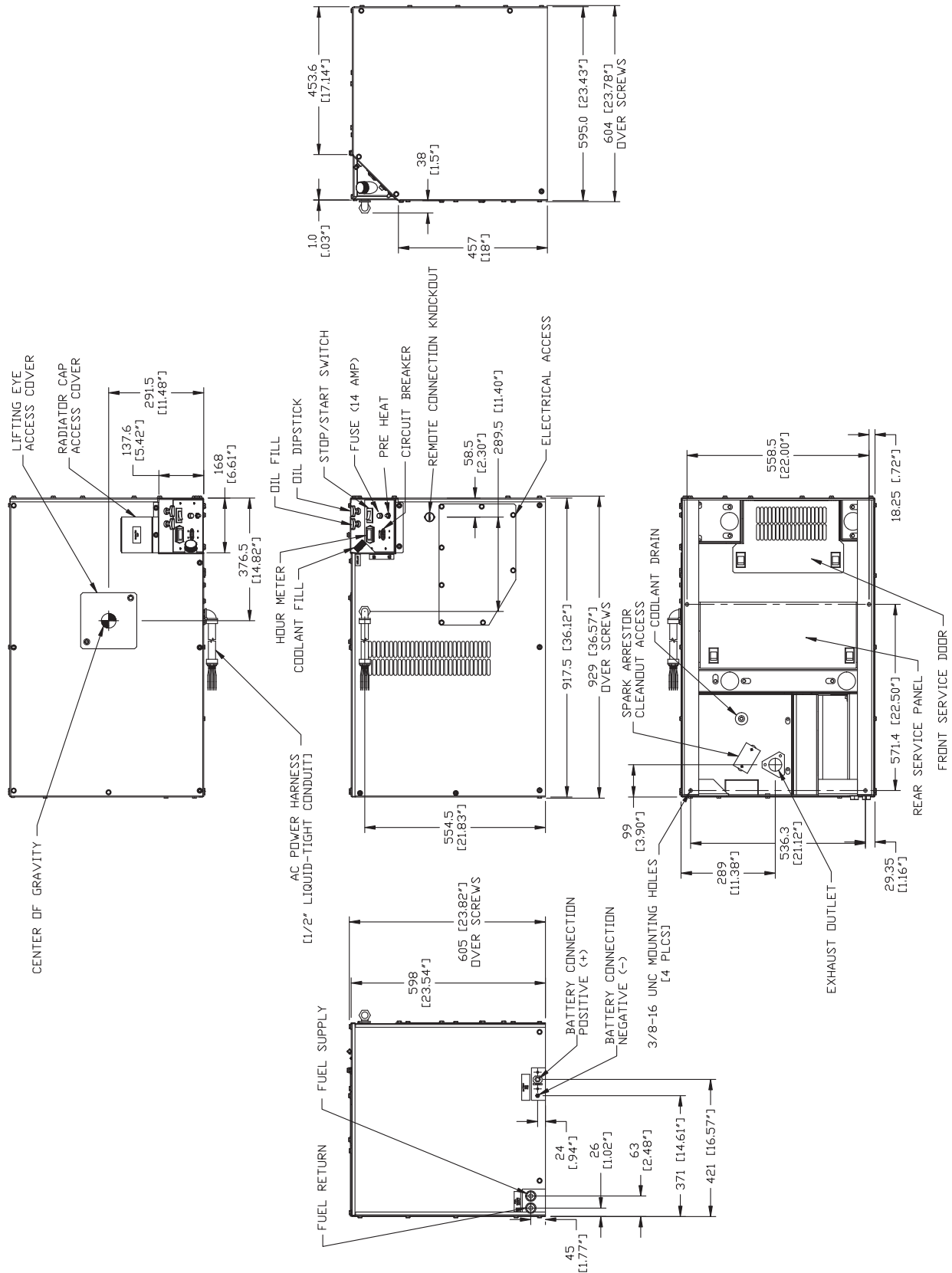

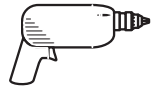

**2.1 LOCATION AND SUPPORT**

Be sure the installation complies with all standards and codes listed in the "Standards Booklets" section of this manual.

**◆ 2.1.1 GENERATOR LOCATION**

The most desirable location for the generator set is between the vehicle's main frame members.

Many recreational vehicles have been factory-equipped with an area for the generator set. Some may even have a generator compartment provided by the vehicle manufacturer.

Plan the generator location based on the following:

- The generator set must be installed on a framework that is part of the recreational vehicle, as outlined in the "Generator Support" section.
- The location must provide an access opening that is large enough to permit generator removal (unless the generator is to be removed from underneath the supporting framework).
- The location must provide easy access to frequently serviced components, such as, filters, oil drains, and other common maintenance parts.
- The location must provide sufficient room to allow minimum clearances for air circulation. If sound insulation is to be used on the compartment walls and ceiling, the minimum recommended clearance applies to the space between the generator and such insulation.
- The location must provide adequate cooling and ventilating airflow for the generator, without a great deal of work and expense.

**◆ 2.1.2 GENERATOR SUPPORT**

The generator must be securely attached to a metal framework that has been affixed to the vehicle frame structure by bolting or welding. The metal framework on which the generator will rest, and which will restrain the generator set, should consist of at least two horizontal beams. These beams should consist of (a) 1-1/2-inch square, 11-gauge steel tubing OR (b) 1-1/2-inch, 11-gauge angle iron.

The generator can be installed so that it sits on top of the horizontal support tubing, if the vehicle design permits. Another method is to suspend the generator below the horizontal support tubing by means of suitable, structurally-sound metal framework. The following general rules apply:

- Vehicle construction **MUST** be capable of supporting the weight of the generator.

- Whether the generator is mounted above the horizontal support tubing or suspended below the tubing, the supporting frame used must be structurally sound.
- If the generator cannot be bolted directly to the supporting frame or support tubing, consider using additional tubing, angle brackets or other supports to give the supporting frame sufficient strength.

**◆ 2.1.3 SUSPENDED MOUNTING**

If the generator will be suspended below the horizontal support tubing, the suspension method used with the vehicle frame members must (a) be able to support the weight of the generator AND (b) provide sufficient restraint for the generator. One typical suspended mounting system is shown in Figure 2.1. The location of a suspended mounting system must be carefully planned, keeping the following general rules in mind:

- Protect the generator against road splash and debris. Baffles or splash guards may be required to protect certain areas of the generator. To make sure the generator is adequately protected, road-test the installation through mud, water, and slush.

**Figure 2.1 – Typical Suspended Mounting System**

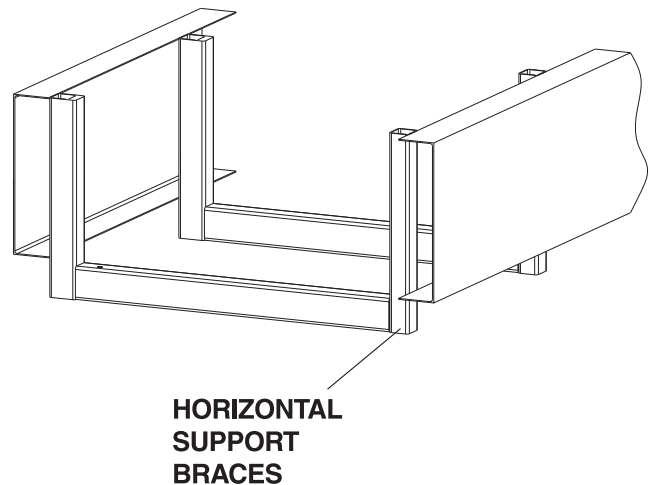

- The installer must make certain that the selected location will permit adequate cooling and ventilating airflow.





### ◆ 2.1.4 GENERATOR RESTRAINT

Use four 3/8"-16 hardened steel bolts (Grade 5) to fasten the generator to the supporting frame or the support tubing. These bolts must pass through (a) the generator mounting base, (b) the compartment floor (if a compartment is used), and (c) the supporting framework (Figure 2.2). All bolts must be long enough so that, when tight, they engage at least 3/8" of an inch [9.5 millimeters]. Refer to the "Generator Compartments" section for the location of the generator mounting holes.

Figure 2.2 – Typical Generator Restraint

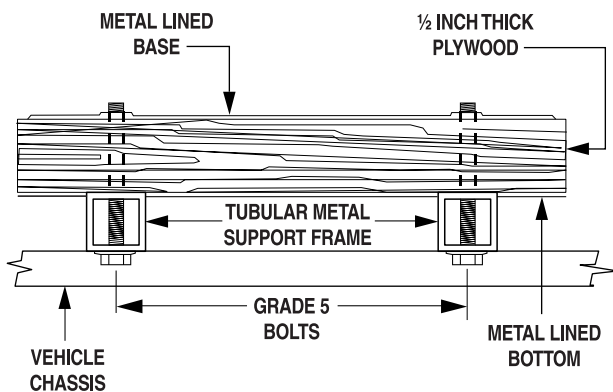

## 2.2 GENERATOR COMPARTMENTS

Whether the generator set is being installed inside a compartment specifically manufactured to house a generator or inside a compartment that the installer constructs, the compartment must meet certain specifications, as outlined in the following sections:

### ◆ 2.2.1 COMPARTMENT CONSTRUCTION

- The generator compartment should be either constructed of, or lined with, 26-gauge galvanized steel.

**NOTE:**

**Aluminum is NOT an acceptable alternative to galvanized steel due to aluminum's low melting point.**

- If the compartment is lined with galvanized steel, it may be constructed of any material. The manufacturer recommends that the compartment be constructed of 1/2-inch thick plywood (not strand-board), with the floor made of a double thickness of 1/2-inch plywood, having the grain of the wood at cross section for added strength (Figure 2.3).

Figure 2.3 – Typical Compartment Construction

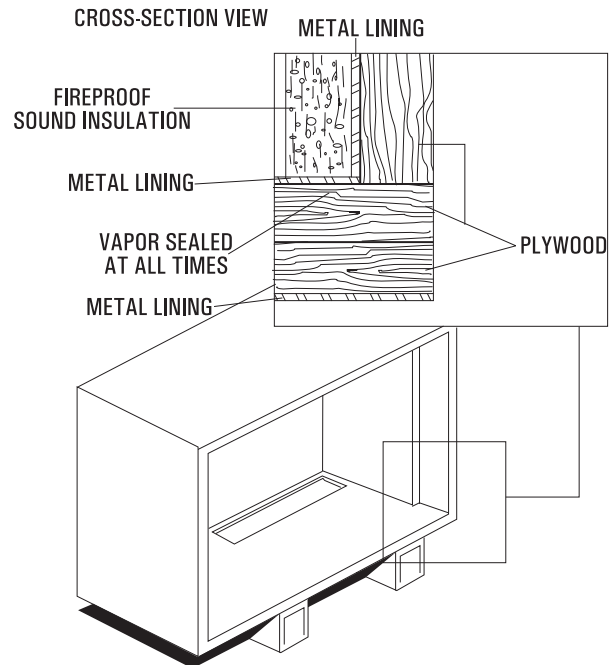

- If constructing a compartment, line the exterior (underside) of the compartment floor with 26-gauge galvanized steel.
- All seams, splices, and joints of the compartment walls (unless vapor-tight by design) should be caulked to prevent poisonous, flammable, or explosive vapors from entering the vehicle interior.

**NOTE:**

**Caulking must be done so that the caulking material will stay in place permanently. Pressing materials such as, putty tape, onto joints and seams is NOT acceptable. A high-quality silicone rubber base sealant is recommended.**

- Holes and openings made in the compartment walls to allow for the passage of electrical conduit, conductors, hoses, cables, etc., into the vehicle living area must be sealed vapor-tight with silicone rubber base sealant.
- If a flexible metal conduit is used, it must be sealed internally at the end, where it terminates inside the compartment's electrical junction box.

**NOTE:**

**Flexible metal conduit, due to its unique construction, is NOT vapor-tight along its entire length.**

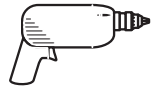

- Seams and joints of the galvanized steel (whether used as a liner or for the compartment itself) must be lapped and mechanically secured. Such seams may be manufactured, welded, bolted, riveted, or screwed. Manufactured lock seams are shown in Figure 2.4. Installer-constructed compartments typically utilize a standard lap joint.

Figure 2.4 – Types of Lock Seams

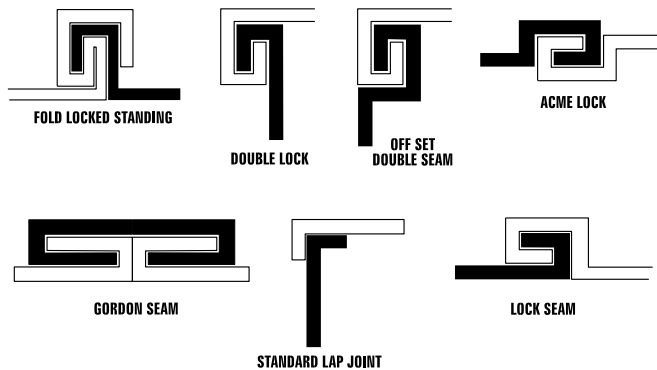

- After the compartment has been metal-lined and vapor-sealed, line the compartment interior walls and ceiling with an approved, nonflammable sound-insulating material. See the "Sound Insulating Materials" section.

**! DANGER !**

- Do not install any flammable material directly above or around the compartment. Heat, transferred through the compartment structure, may be sufficient to ignite, char, or discolor seat cushions, fiberboard, and other flammable materials. Use approved, nonflammable insulating materials in high temperature areas.

**◆ 2.2.2 SOUND INSULATING MATERIALS**

Once installers have determined that a compartment is properly constructed and metal-lined, they can add acoustical material. This may include additional sealant or insulating material, to reflect noise away from the vehicle interior.

Sound insulating materials should be of a nonflammable type. One excellent insulating material is a 1-inch (25 mm) thick fiberglass having a 2-pound density. When fiberglass is used, its coated side should face toward the compartment interior.

**! DANGER !**

- Do not install sound insulation or any absorbent material on the compartment floor interior. Such materials will become soaked with combustible or explosive vapors and liquids and will become a fire hazard.

Using a combination of sound-insulating materials can often reduce noise more effectively than a single material. For example, a sheet of lead or visco-elastic material, along with a layer of other acoustical material, is more effective than when a single material is used.

**◆ 2.2.3 ACOUSTICS**

For additional noise abatement, the installer may wish to consider the following:

- Using special sound-insulating materials.
- Construction of a special noise abatement compartment.

**NOTE:**

**Any method used to reduce noise must not adversely affect the flow of cooling and ventilating air into, or out of, the compartment.**

In addition to the effective use of sound insulating materials, construction of a special noise abatement compartment might be considered to reduce noise levels. Such a compartment might be constructed as follows (Figure 2.5):

- Use 5/8-inch thick or 3/4-inch thick plywood in the compartment.
- Construct the compartment floor of a double thickness of 5/8-inch or 3/4-inch plywood.
- Line the compartment's interior walls and floor, as well as the underside of the floor, with 26-gauge galvanized steel.
- Vapor-seal all compartment seams and joints.
- Over the galvanized steel lining, install a combination of acoustical materials, as mentioned in the "Sound Insulating Materials" section.

**! DANGER !**

- To prevent fire or explosion, do not install any insulation, or other absorbent materials, on the interior or underside of the compartment floor.
- Seal all compartment door edges to prevent noise leakage around the door perimeter.
- Line the compartment door interior (except for air openings) with suitable, fireproof sound insulation (such as, 1-inch (25 mm) thick fiberglass with a 2-pound density).

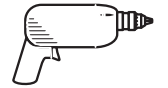
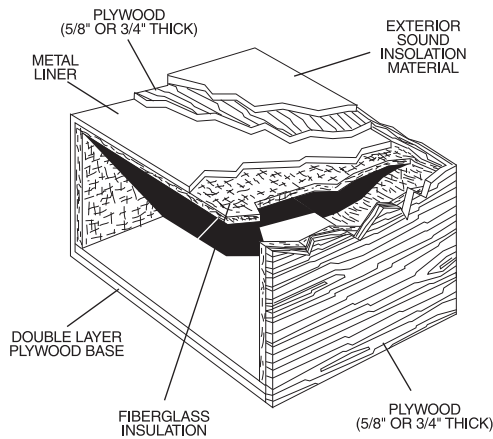

Figure 2.5 – Typical Noise Abatement



◆ 2.2.4 COMPARTMENT FLOOR CUTOUTS

Provide openings in the generator compartment for the following items (Figure 2.6):

- Engine exhaust and cooling air outlets
- Generator cooling air inlet and front service door
- Four holes for passage of generator mounting bolts. See the "Generator Restraint" section.
- Rear service door.



⚠ Fuel lines and exhaust piping must not penetrate into the vehicle living area.

Figure 2.6 – Compartment Floor Cutout

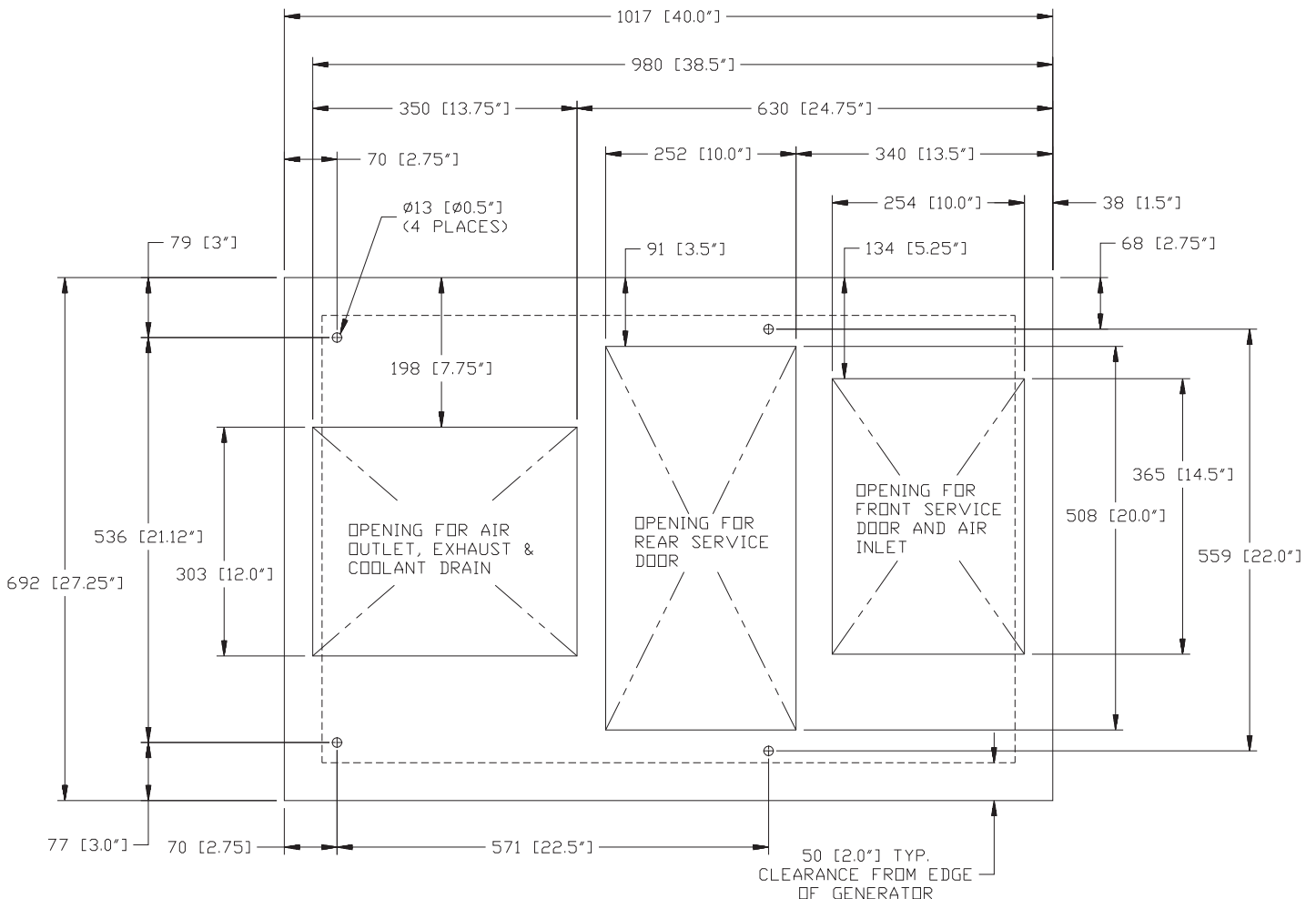

NOTE: FOR A FULL SIZE TEMPLATE, CONTACT GENERAC SERVICE DEPARTMENT AT: 1-262-544-4811

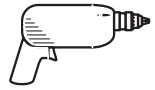

### 2.3 COOLING AND VENTILATING AIR

It is absolutely essential that an adequate flow of air for cooling, ventilation, and engine combustion be supplied to the generator set. Without sufficient airflow, the engine/generator quickly overheats. Such overheating can cause serious operating difficulties and also may cause fire and personal injury. The installer must make sure that sufficient air is available to the generator for cooling, ventilating, and combustion. The installer also must provide a path for exhausting the cooling air to the exterior of a compartment, if so equipped.



⚠ Never use discharged cooling air for heating or permit such air to enter the vehicle interior. This air contains deadly carbon monoxide gas and other poisonous, flammable, or explosive gases.

#### 2.3.1 GENERATOR AIRFLOW

This unit uses an impellar fan located on the alternator drive pulley to cool the alternator's internal components. Air is drawn through the alternator and expelled radially behind the drive pulley. An engine-driven centrifugal blower draws in cooling air through air inlet openings, moves that air around the engine/generator and across the radiator, then discharges that air out the bottom (see Figure 2.7).

Figure 2.7 – Airflow Through Engine/Generator

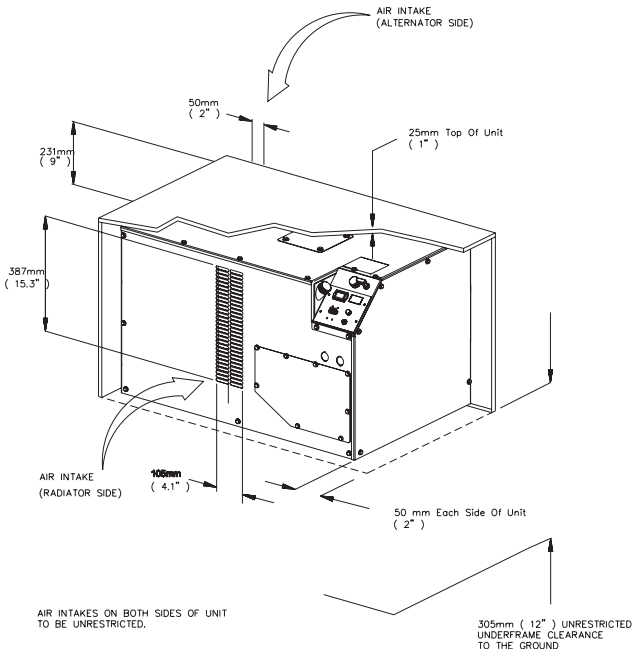

#### 2.3.2 COOLING AIR INLET OPENINGS

The minimum size of the air inlet opening, whether the generator is housed in a conventional compartment or not, is **at least 150 square inches (975 cm<sup>2</sup>)** (see Figure 2.8). This rule applies whether inlet air is brought in through an opening in the compartment door, an opening in the vehicle skirt, through duct work, or by any other means.

**NOTE:**

**Screening, louvers, or expanded metal that cover air openings restrict airflow. Compensate for this by making the actual air opening proportionately larger. See the "Compensating for Restrictions" section.**

Figure 2.8 – Air Inlet in Compartment Door

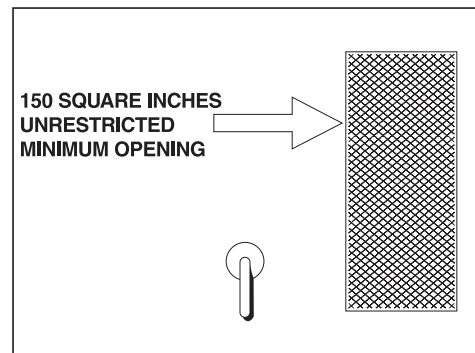

When the unit is installed on a suspended mounting system, one of several different methods of supplying airflow may be used as follows:

- Provide a door in the vehicle skirt having an air inlet opening (Figure 2.9).

Figure 2.9 – Suspended Mount: Inlet Door

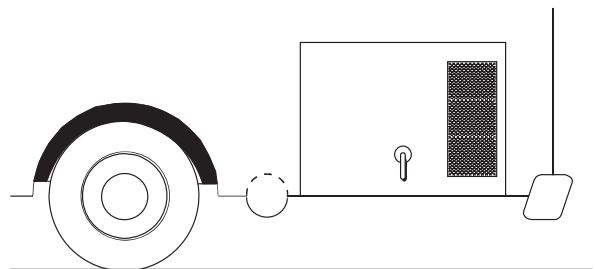

- Use duct work (Figure 2.10). The installer must be sure air is available to the sides of the generator for proper air intake.
- Provide an opening in the vehicle skirt and space around the generator for cooling airflow (Figure 2.11). Recommended clearance around all sides of the generator is at least two inches (50 mm).



Figure 2.10 – Air Inlet Using Duct work

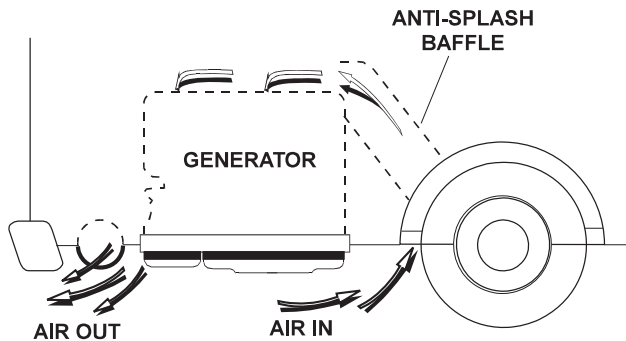
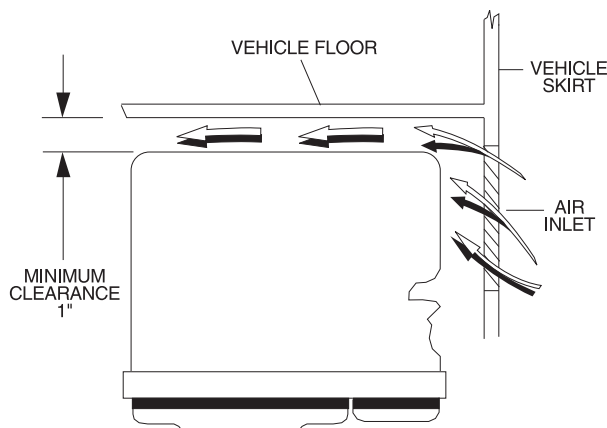

Figure 2.11 – Air Inlet in Vehicle Skirt



### ◆ 2.3.3 COMPENSATING FOR RESTRICTIONS

Materials, such as, screening, louvers, or expanded metal, can restrict the free flow of air. Compensate for this restriction by making the actual air opening proportionately larger.

Some materials may offer only a 60 percent “free air inlet area.” Other more efficient materials may provide up to a 90 percent free air inlet area. The percentage of free air inlet opening is usually available from the material’s supplier or manufacturer.

**To determine the actual air inlet opening size required, divide 150 square inches (975 cm<sup>2</sup>) by the percentage of free air inlet area for the material being used.**

**For example:** If planning to use screening with an 80 percent free air inlet area, divide 150 (975) by 0.8, which results in 187.5 square inches (1,218.75 cm<sup>2</sup>). Minimum actual size of air inlet opening in this case is 187.5 square inches (1,218.75 cm<sup>2</sup>).

### ◆ 2.3.4 TESTING THE INSTALLATION

The manufacturer recommends testing the installation to be sure adequate cooling airflow is available to the unit, before placing the unit into service. If the unit shows signs of overheating, enlarge the air openings. Never place a unit into service until absolutely certain that cooling and ventilation is adequate.

**NOTE:**

**The installation must be tested, especially if bringing in air from below the generator set.**

## 2.4 DIESEL FUEL SYSTEM

The installation of a diesel fuel system (Figure 2.12) for a recreational vehicle generator set must comply with applicable codes, standards, and regulations. The entire fuel system must be completely free of leaks. There must be no possibility of fuel vapors entering the vehicle interior.

Figure 2.12 – Generator Fuel System

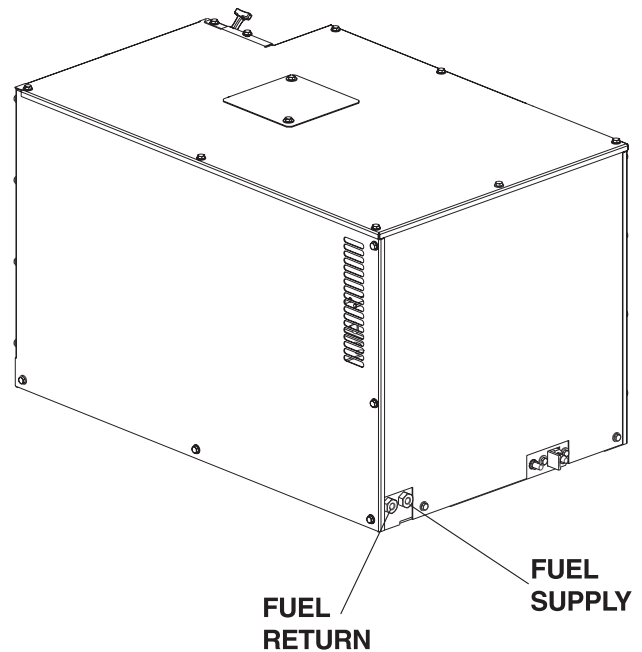

**▲ DANGER ▲**

**▲ All fuel types are potentially FLAMMABLE and/or EXPLOSIVE and should be handled with care. Comply with all laws regulating the storage and handling of fuels. Properly install and maintain the fuel system, and keep it entirely free of leaks. Fuel vapors must not enter the vehicle interior.**

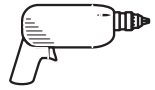

Because diesel fuels are less volatile than gasoline or gaseous fuels, they are considered safer from the standpoint of storage and handling. As a result, installers may tend to be careless in their installation practices, which can result in poor engine performance. For example, a poorly tightened fuel line may not show any signs of leakage; however, air can be drawn into the loose connection and cause problems. Air that is trapped in the diesel fuel system results in hard starting and rough engine operation.

Dirt that enters the fuel system also may cause problems. Lines and piping must be properly installed and tightened to prevent dirt from entering. Diesel fuel must be kept clean.

Factory-installed generator fuel system components include (a) a fuel filter, (b) a 12-volt DC electric pump, (c) an injection pump, and (d) interconnecting lines and fittings. Connect a fuel supply line to the supply fitting and a return line from the fuel return fitting back to the tank.

**NOTE:**

**Fuel supply and return fittings located on the generator are 1/8" NPT.**

Use a length of approved flexible fuel hose between the fuel connection fittings and rigid fuel lines (see the Generator Fuel Supply Lines" and "Generator Fuel Return Lines" sections.

### ◆ 2.4.1 FUEL TANK

Either the generator must share the vehicle's engine fuel tank, or a separate fuel tank for the generator set must be installed. All fuel tanks installed on the vehicle must be constructed, installed, and restrained so they comply with applicable codes, standards, and regulations.

If the generator is to share the vehicle's engine tank, separate fuel pickup tubes are required for the engine and the generator. The manufacturer recommends that the fuel pickup tube be two to three inches (51 to 76 mm) shorter than the vehicle's engine pickup tube. This prevents the generator from depleting the entire fuel supply during prolonged generator operating periods.

**CAUTION**

⚠ Do NOT tee the generator fuel supply line into the vehicle engine fuel supply line. If this is done, the generator will be starved of fuel when both engines are operating at the same time. Also, while the vehicle engine is not running, generator operation may drain the vehicle engine supply line, making it difficult to start the vehicle engine.

### ◆ 2.4.2 GENERATOR FUEL SUPPLY LINES

#### ✦ 2.4.2.1 Rigid Fuel Lines

Those lines used to supply fuel from a tank to the generator must comply with applicable codes, standards, and regulations. The following general rules apply to rigid fuel lines:

- Rigid lines should be of annealed, seamless, drawn aluminum, or steel.
- Lines and fittings must comply with SAE J512F, "Standard Automotive Fittings," or with ANSI B126.26 (latest edition).
- Route the fuel line so that at least 2 inches (51 mm) of clearance is maintained between the line and any exhaust system parts.
- Do not attach electrical wiring to fuel lines. Route the wiring so it cannot come into contact with any fuel line.
- Route fuel lines so that, if they leak, fuel does not drip onto any electrical or exhaust system parts.
- Use nonferrous metal straps without sharp edges to secure fuel lines.
- Fuel system components must be accessible, but protected from abrasion, chafing, road damage, and kinking.

#### ✦ 2.4.2.2 Flexible Fuel Line

Use a length of approved flexible fuel hose between the generator fuel supply fitting and rigid fuel lines. This prevents breaking of the line caused by vibration, shifting, settling, or movement. The following rules apply:

- The flexible hose must comply with SAE J1137 (30R7), "Standard for Fuel and Oil Hose." It must be approved for use with diesel fuel and low permeability.
- The hose should be at least 6 inches (152 mm) longer than is needed, to prevent the hose from rupturing if the generator shifts or settles.

### ◆ 2.4.3 GENERATOR FUEL RETURN LINES

The same general rules that apply to fuel supply lines also apply to fuel return lines.

**NOTE:**

**Locate the diesel fuel return line at least 12 inches from the tank fuel pickup tubes to prevent air bubbles from entering the fuel supply lines.**



## 2.5 EXHAUST SYSTEM

The generator exhaust system must be safely and properly installed. Only approved exhaust system parts must be used. A properly installed exhaust system must be vapor-tight, quiet, and completely safe.

### ⚠ DANGER ⚠

⚠ The generator engine gives off **DEADLY** carbon monoxide gas through its exhaust system. This dangerous gas, if breathed in sufficient concentrations, can cause unconsciousness or even death. Never operate the generator set with the vehicle inside any garage or other enclosed area. **DO NOT OPERATE THE GENERATOR IF THE EXHAUST SYSTEM IS LEAKING OR HAS BEEN DAMAGED. SYMPTOMS OF CARBON MONOXIDE POISONING ARE (a) inability to think coherently, (b) vomiting, (c) twitching muscles, (d) throbbing temples, (e) dizziness, (f) headaches, (g) weakness, and (h) sleepiness. IF FEELING ANY OF THESE SYMPTOMS, MOVE INTO FRESH AIR IMMEDIATELY. IF SYMPTOMS PERSIST, GET MEDICAL HELP.** Do not operate the generator until its exhaust system has been inspected and properly repaired.

### ⚠ CAUTION ⚠

⚠ Never tee the generator engine exhaust pipe into the vehicle engine exhaust piping. This causes excessive back pressure on the generator engine. Also, water from one engine can damage the other engine.

### ◆ 2.5.1 MUFFLER AND SPARK ARRESTOR

The exhaust muffler supplied with this unit is a spark arrestor type that meets code and standard requirements of the U.S. Forest Service. Any person(s) installing an unapproved muffler, or an unapproved exhaust system part, or modifying an exhaust system in any way that might cause a hazard, is liable for any damage, injury, or warranty expense that might be caused by such unapproved installation or modification.

### ◆ 2.5.2 EXHAUST SYSTEM SAFETY

- Maintain a clearance of at least 3 inches (76 mm) between exhaust system parts and any combustible material (such as, wood, felt, cotton, organic fibers, or other like material). If the 3-inch (76 mm) clearance cannot be maintained, locate, insulate, or shield the exhaust part(s) so that the temperature of any combustible material is not raised to more than 117° F (65° C) above the ambient air temperature.
- Terminate the exhaust tailpipe at least 3 feet (91 cm) from the vehicle's fuel filler cap and at least 2 inches (51 mm) past the outer edge of the vehicle. Do not terminate the exhaust system under the vehicle.
- Terminate the exhaust tailpipe such that exhaust gases will not be drawn back into the generator compartment and recirculated.
- Fuel and oil must NOT be able to drip onto any exhaust system part.

Figure 2.13 – Typical Exhaust System

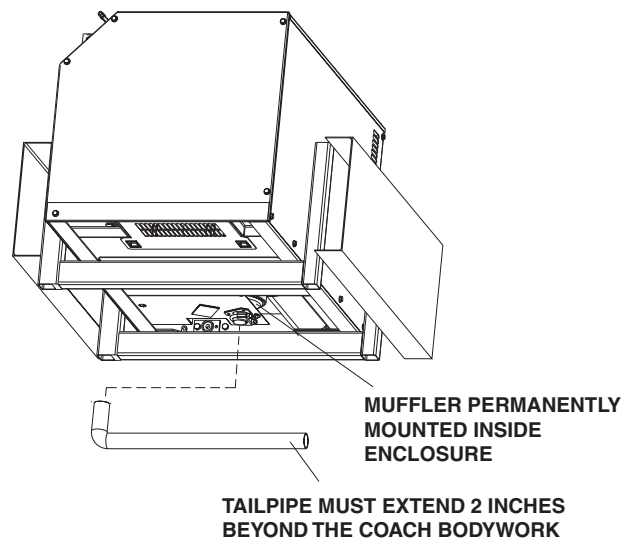

- If there is any possibility of the tailpipe or muffler being damaged, protect these damage-prone areas by means of a protective device (such as, a skid bar).
- Install the generator exhaust system according to safe automotive practices.
- Use enough exhaust system hangers to prevent any part of the system from being dislocated.

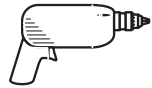

- Use exhaust system parts recommended by the manufacturer. Using unapproved exhaust mufflers and exhaust system parts is the responsibility of the person(s) installing such unauthorized parts.
- Do not terminate the exhaust system under any opening, window, or vent that can be opened or is not permanently sealed from the vehicle interior.
- Exhaust piping must be large enough to prevent excessive back pressure on the generator engine.
- Never tee the generator engine exhaust pipe into the vehicle engine exhaust piping. This causes excessive back pressure on the generator engine. Also, water from one engine can damage the other engine.
- Plan exhaust system installation carefully. Comply with all applicable codes, standards, and regulations.

## 2.6 ELECTRICAL CONNECTIONS

Be sure to read the "Generator AC Connection System" section.

The following general rules apply to electrical connections in a recreational vehicle:

- Qualified electricians who are familiar with applicable codes, standards, and regulations should install electrical wiring.
- The wiring should comply with codes, standards, and regulations. The National Electrical Code (NFPA 70), and state and local codes apply.
- Switches and circuit breakers should be of a type approved for use in recreational vehicles and must be mounted and installed to prevent damage from road shock.
- Wiring must be of adequate size, have approved insulative qualities, and be properly supported.
- Conduit and wire openings into the generator compartment (if used) must be vapor-sealed to prevent entry of flammable, explosive, or poisonous gases into the vehicle.

### ◆ 2.6.1 ELECTRICAL JUNCTION BOX

Install an approved, square electrical junction box with a blank cover on the interior or exterior wall of the area planned for installation of the generator (NOT on the generator). Route the generator's AC output leads into this junction box through approved flexible conduit. This is the point of first termination for generator AC output leads.

### ◆ 2.6.2 WIRING

- Wiring should be of stranded copper to reduce the chance that vibration may cause breakage.
- Wire gauge size should be large enough to handle at least 115 percent of the installed generator's rated maximum current.

- If neutral conductors are used, they must be the same size as other leg wires.
- Route power supply conductors from generator AC output leads T1 (red), T2 (white), T3 (black), and the green ground wire through approved flexible conduit to the electrical junction box on the compartment wall.

If a flexible metal conduit is used between the generator and the compartment junction box, the conduit end that terminates at the compartment junction box must be vapor-sealed. Flexible metal conduit is NOT vapor-tight along its entire length.

- From the junction box, route power supply wires through approved conduit to either (a) double-pole, double-throw transfer switch, or (b) approved isolation receptacle. Connecting to a transfer switch or isolation receptacle must prevent vehicle electrical circuits from being connected to two different power supplies at the same time (such as, generator and dockside power).
- Conductors must be rated 221° F (105° C) or must be of a larger conductor size.

When connecting vehicle load leads, the following rules apply:

- Connect 120-volt, single-phase, 60-Hertz, AC electrical loads, requiring up to the trip rating of circuit breaker CB1, across AC output leads T1 (red) and T2 (white).
- Connect 120-volt, single-phase, 60-Hertz, AC electrical loads, requiring up to the trip rating of circuit breaker CB1A, across AC output leads T3 (black) and T2 (white).
- Try to keep the load balanced between the two circuit breakers and the stator windings.
- The neutral line (T2, white) on all units is a grounded neutral.

### ◆ 2.6.3 GENERATOR AC CONNECTIONS

Generator AC output leads T1 (red), T2 (white), and T3 (black) come out of the generator, as shown in Figure 2.14. Leads T1 (red) and T3 (black) are "hot," while T2 (white) is the grounded neutral lead. There is also a green lead that connects to ground in the junction box of the recreational vehicle.

These generators use a four-position terminal block to connect between stator power leads and vehicle load leads. This terminal block is accessible by removing the access panel, shown in Figure 2.14. Units are shipped from the factory connected for dual-circuits (120 volts AC) output (See Figure 2.15). Two stator power windings are used, with each winding capable of supplying half of the unit's rated wattage/ampere capacity. The circuit from each winding is protected against overload by a line breaker (CB1 and CB1A). Line breakers CB1 and CB1A have a trip rating of 40 amps.





Figure 2.14 – Generator AC Output Leads

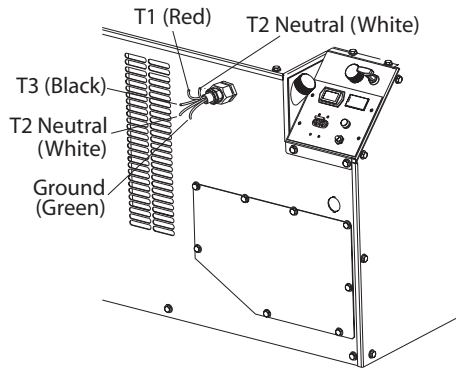

### ✦ 2.6.3.1 Generator Conversion to 120/240 Volt Dual Voltage

**NOTE:**

Conversion of this generator from "120 volts only, dual circuits" to "120/240 volt - dual circuits" (or vice-versa) requires rerouting wires within the unit enclosure. It is recommended that this conversion be performed by an Authorized Service Dealer.

Figure 2.16 shows the stator power winding connections for 120/240 volt dual voltage. The stator power windings are connected in series. Lead 11/11A connects to T1 (Red), lead 44/44A connects to T3 (Black), while leads 22 and 33 are grounded and connect to T2 NEUTRAL (White). A "tie bar" connects the two switch handles on line breaker CB1.

To convert from "120 volt dual circuits" to "120/240 volt dual voltage", disconnect battery power from the generator and reverse stator lead wires 33 and 44 as follows:

**NOTE:**

It is necessary to feed stator lead wires 33 and 44 through grommets on the electrical enclosure and engine control box in order to perform the rerouting outlined below. The front and top unit enclosure panels, as well as the user control panel, must be removed to perform this. After re-routing, wires should be properly tied down to prevent chafing or contact with moving internal components

1. Remove stator lead wire 44, as shown in Figure 2.15, from the ground stud adjacent to the four-position terminal block. Reroute stator lead 33 from the line side terminal of CB1A (renamed as CB1 in Figure 2.16) to the ground stud location previously occupied by stator lead wire 44.
2. Move smaller gauge (#18 AWG) wire labeled #11 (not shown), from the top of CB1 to the top of CB1A. Renumber this wire #44.
3. Reroute stator lead wire 44, removed in step 1, to the line side terminal on CB1.

4. Renumber ground wire "44", located between the four-position terminal block and ground in Figure 2.15, as ground wire "33", as shown in Figure 2.16.
5. Renumber wire "33A" from Figure 2.15 as wire "44A" in Figure 2.16.
6. Remove the 12 AWG jumper wire from between line breakers CB1 and CB1A, as shown in Figure 2.15.
7. Install a "tie bar" between the two-line breaker switch handles.



⚠ Do NOT connect electrical loads in excess of any circuit breaker rating, or problems will develop with circuit breaker tripping, which causes a loss of AC output. Also, do NOT exceed the generator's rated wattage capacity. Add the watts or amps of all lighting, appliance, tool, and motor loads the generator will operate at one time. This total should be less than the unit's rated wattage/ampere capacity.

Figure 2.15 – Connections for 120 Volts Only — Dual Circuits

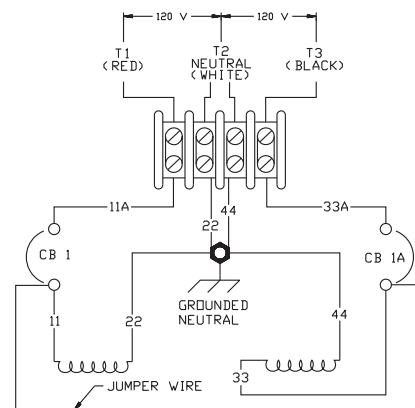
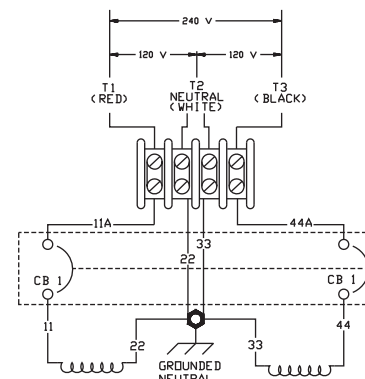
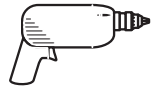

Figure 2.16 – Connections for 120/240 Dual Voltage





◆ 2.6.4 CONDUIT

Route the connections between the generator and the junction box through approved, flexible conduit. The following general rules apply:

- All wiring, conduit, and interconnections must be installed in compliance with applicable codes, standards, and regulations.
- Cut wiring to the required length, and allow extra wire for junction box connections.
- Carefully prepare conduit ends to prevent sharp edges from cutting through wiring insulation.
- Route conduit so it does not interfere with generator movement.
- If using metallic conduit, vapor-seal the end of the conduit where it enters the junction box. Do this because flexible metallic conduit is not vapor proof along its entire length.
- All openings in the generator compartment for the passage of wiring and conduit must be sealed and made vapor-tight.

**NOTE:**

**Use a high-quality silicone rubber base sealant or other approved method (such as, explosion-proof fittings) to seal such openings.**

◆ 2.6.5 POWER SUPPLY CORD

The power supply cord must comply with all applicable codes, standards, and regulations. It must be large enough to handle the full amperage to which it will be subjected.

◆ 2.6.6 GROUND FAULT CIRCUIT INTERRUPTERS

The National Electrical Code (NFPA 70, 551-7) requires that ground-fault circuit interrupters (GFCIs) be installed on all external and some internal electrical receptacles. Contact the manufacturer or dealer for recommendations.

◆ 2.6.7 ISOLATING DIFFERENT POWER SOURCES

Connections from the junction box must terminate in a double-pole, double-throw transfer switch (Figure 2.17). An alternate method for isolating different power sources includes using an isolating receptacle (Figure 2.18). Whichever method is used, be certain that both power sources are NOT connected at the same time.

Figure 2.17 – Transfer Switch Isolation Method

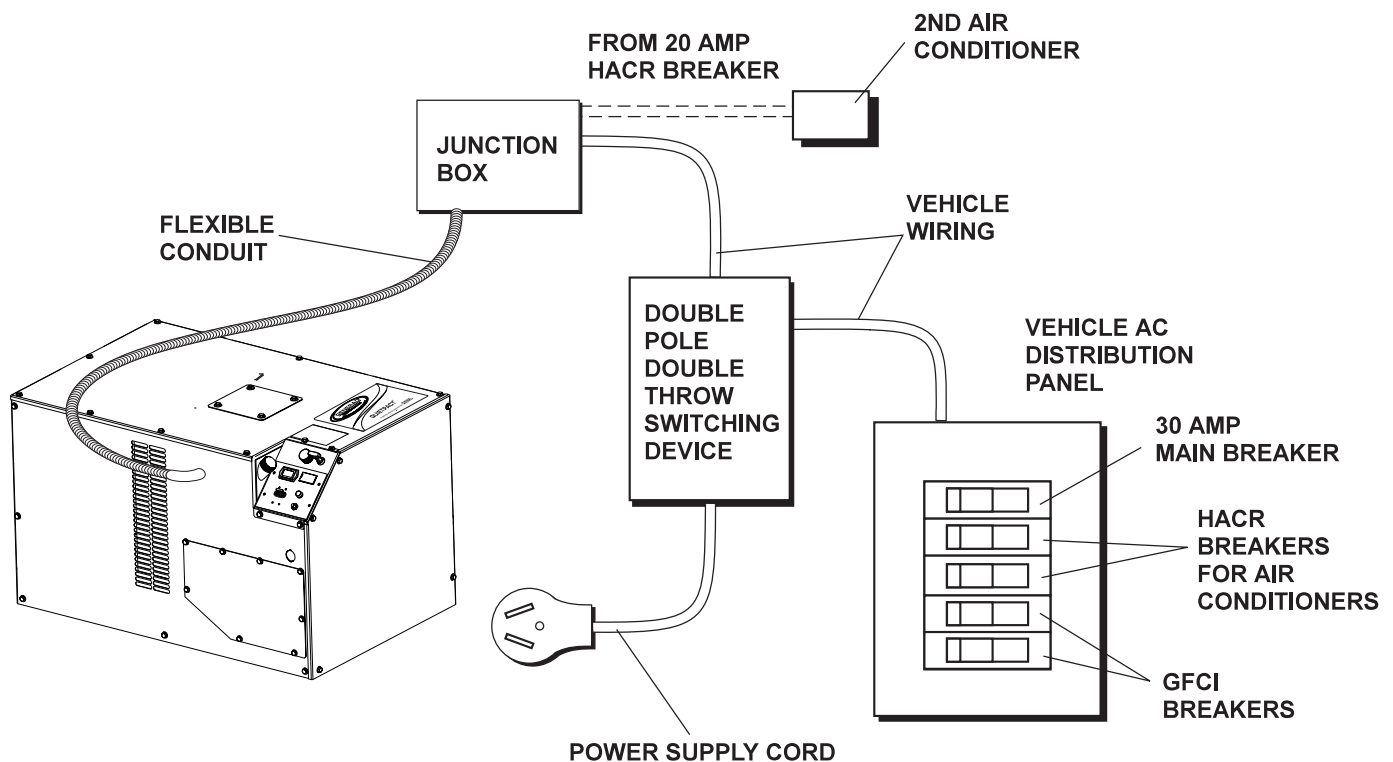
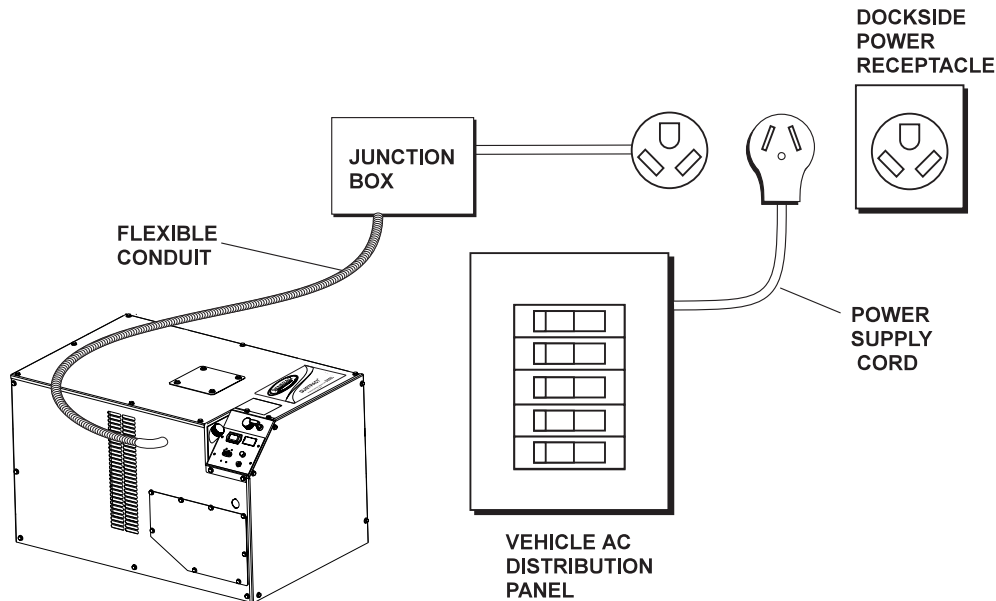

Figure 2.18 – Installation With Isolation Receptacle



**⚠ DANGER ⚠**

⚠ If the vehicle's electrical circuits can be powered by any other source of electricity (such as, a "dockside" power receptacle), there must be no possibility of connecting the different power sources to the vehicle's circuits at the same time. The dockside (utility) power source must be positively isolated from the vehicle's circuits whenever the generator is operating. Failure to isolate the vehicle's circuits from the dockside power supply when the generator is running may result in damage to the generator or in serious injury or death to dockside (utility) power workers due to backfeed of electrical energy. Installation and connection of the generator must comply with NFPA 70, Article 551, and NFPA 1192 (latest editions).

## 2.7 BATTERY INSTALLATION

### ◆ 2.7.1 RECOMMENDED BATTERY

Install a battery that meets the following requirements:

- The battery must be a 12-volt, automotive-type storage battery.
- Use a battery with minimum ratings of 70 amp-hours and 600 cold-cranking amps.

**NOTE:**

If the battery is to be used to power other vehicle accessories, as well as to start the generator, a battery with a larger capacity may be necessary.

### ◆ 2.7.2 BATTERY CABLES

Using battery cables that are too long or too small in diameter may cause a drop in voltage, which causes starting problems. For the best cold weather starting, the voltage drop between battery terminals and the generator connection point should not exceed 0.12 volts per 100 amps of cranking current.

The generator is rated at about 160 DC amps of cranking current to operate the starter and glow plugs.

Select battery cables based on (a) cable length and (b) prevailing ambient temperatures. Generally, the longer the cable and the colder the weather, the larger the cable size must be, as shown in the chart.

CABLE LENGTH in Feet (meters)	CABLE SIZE
0 to 10 (0 to 3)	2*
11 to 15 (3.4 to 4.5)	0
16 to 20 (4.5 to 6)	000
*For warm weather, use No. 2 cable up to 20 feet.	

### ◆ 2.7.3 BATTERY CABLE CONNECTIONS

1. Connect the battery cable from the battery post or terminal, indicated by a POSITIVE, POS, or (+), to the insulated lug on the unit frame (Figure 2.19).

**NOTE:**

Check to be sure the cable boot for the positive cable has been installed.

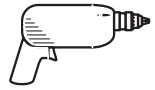

2. Connect the battery cable from the battery post, indicated by a NEGATIVE, NEG, or (-), to the vehicle frame ground connection (Figure 2.19).
3. Connect a cable from the vehicle frame ground to the negative post on the generator frame.
4. Connect cables so the connectors are clean and tight.

Figure 2.19 – Connecting Battery Cables

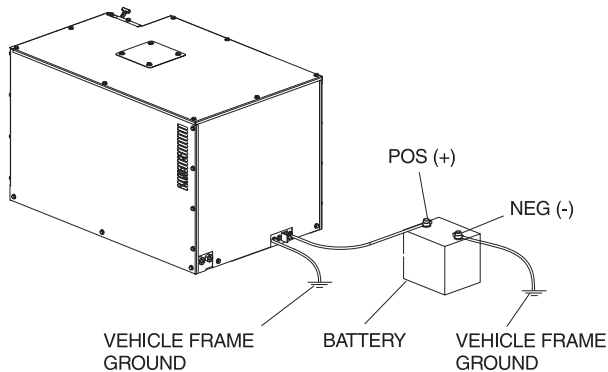

### ◆ 2.7.4 BATTERY COMPARTMENT

Install the generator battery in its own, vented compartment. Place the battery compartment away from any source of heat, sparks, or flame.

Provide ventilation openings in the battery compartment. The minimum size of openings should be 2 square inches at the top of the compartment. Mount the battery on a strong, rigid supporting structure, where leaks and spills of battery fluid will not cause damage.



⚠ Do not dispose of the battery in a fire. The battery is capable of exploding. Storage batteries give off explosive hydrogen gas. This gas can form an explosive mixture around the battery for several hours after charging. The slightest spark can ignite the gas and cause an explosion. Such an explosion can shatter the battery and cause blindness or other injury. Any area that houses a storage battery must be properly ventilated. Do not allow smoking, open flame, sparks, or any spark-producing tool or equipment near the battery. Discharge static electricity from body before touching the battery by first touching a grounded metal surface.

⚠ A battery presents a risk of electrical shock and high short-circuit current. The following precautions are to be observed when working on batteries:

- Remove watches, rings, or other metal objects;

- Use tools with insulated handles;
- Wear rubber gloves and boots;
- Do not lay tools or metal parts on top of the battery;
- Disconnect any charging source prior to connecting or disconnecting battery terminals; and
- Do not use any jumper cables or booster battery to crank and start the generator engine. If any battery has discharged, remove it for recharging.



⚠ Do not open or mutilate the battery. Released electrolyte is known to be harmful to the skin and eyes, and to be toxic.

⚠ The electrolyte is a dilute sulfuric acid that is harmful to the skin and eyes. It is electrically conductive and corrosive. The following procedures are to be observed:

- Wear full eye protection and protective clothing;
- Where electrolyte contacts the skin, wash it off immediately with water.
- If the electrolyte contacts the eyes, immediately flush eyes thoroughly with water, and seek medical attention.
- Spilled electrolyte is to be washed down with an acid-neutralizing agent. A common practice is to use a solution of 1 pound (500 grams) bicarbonate of soda to 1 gallon (4 liters) of water. The bicarbonate of soda solution is to be added until the evidence of reaction (foaming) has ceased. The resulting liquid is to be flushed with water and the area dried.

### 2.8 OPTIONAL ACCESSORIES

A plug-in connector (Figure 2.20) is provided on the generator set, below the control panel. Use this to connect an optional remote-mounted start/stop panel to the generator. Installation of such a panel will permit starting and stopping the generator engine from any convenient location inside the vehicle.

Figure 2.20 – Remote Panel Plug-in Receptacle

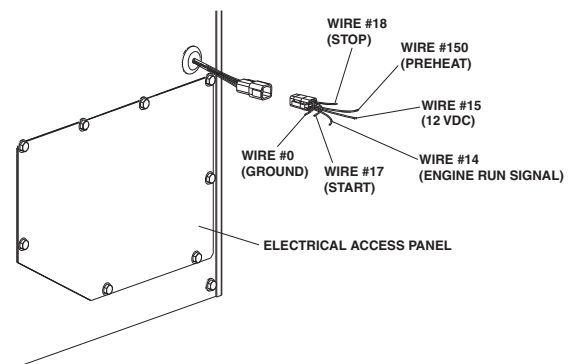

### ◆ 2.8.1 REMOTE START/STOP CONNECTIONS

The following steps are necessary to connect the remote start/stop option:

1. If the six-wire remote connector is visible below the control panel, as shown in Figure 2.20, skip to step 5. Otherwise, proceed with step 2.
2. Remove the electrical access panel located just below the knock-out labeled "REMOTE." The remote connector will be located inside the electrical enclosure, along the right side.
3. Remove the "REMOTE" knock-out, taking care not to damage the wiring behind it.
4. Feed the remote connector through the hole, and fit the supplied grommet into position.
5. Wire the remote harness (Part # OD2021C, supplied as an accessory with the generator) to the vehicle's remote start panel. Refer to Figure 2.20 for a wiring legend.
6. Plug the remote harness into the mating remote connector on the generator.

### 3.1 POST INSTALLATION TESTS

The generator set was factory-tested and adjusted. It is not necessary to adjust the unit any further, except under special circumstances.



- ⚠ Do not make any unnecessary adjustments. Factory settings are correct for most applications. When making adjustments, however, be careful to avoid overspeeding the engine.

### 3.2 BEFORE INITIAL STARTUP

Before starting, complete the following:

1. Check the engine crankcase oil level and, if necessary, fill to the dipstick "FULL" mark (cross-hatched area) with the recommended oil. Do not fill above the FULL mark.
2. Check the fuel supply. Fuel lines must have been properly purged and leak-tested in accordance with applicable fuel codes. All fuel shutoff valves in the fuel supply lines must be open.

### 3.3 INITIAL START

When absolutely certain that the unit has been properly installed and prepared for use, start the engine as follows:

1. Turn off all electrical loads. Do this by setting the generator's line breakers to their "OFF" (or open) position.

2. Refer to Part I, the "Starting the Generator" section, for cranking and starting instructions. The engine may require more cranking for initial starting, since the fuel lines have to be primed (use of the preheat switch will operate the generator's electrical fuel pump and shorten this time).
3. Let the engine warm up for about five minutes to allow internal temperatures to stabilize.
4. Carefully inspect the engine/generator for fuel, oil, and exhaust system leaks. Before proceeding to the next step, correct any leakage immediately.
5. When all tests and adjustments at no-load are completed, apply electrical loads and check for proper operation under load. See the "Testing Under Load" section. Run the unit at least 30 minutes, with loads applied.
6. Turn off all electrical loads by setting the generator's line breakers to their "OFF" (or OPEN) position.
7. Let the unit run at no-load for a few minutes to stabilize internal engine/generator temperatures. Then, shut down the engine.



- ⚠ The generator set was thoroughly tested and adjusted at the factory before shipping. No additional adjustment should be necessary. Only trained, qualified service technicians should perform adjustments outlined in this manual.

### 3.4 TESTING UNDER LOAD

Apply electrical loads equal to about 50 to 75 percent of the unit's rated wattage/ampere capacity.

Let the unit run at least 30 minutes with load applied. During this part of the test, check that the unit is not running excessively hot and that adequate cooling airflow is available. Do not allow the unit to overheat during prolonged operation.

#### NOTE:

**The generator engine is equipped with a high coolant temperature switch. The switch has normally open (N.O.) contacts. When the engine coolant temperature is too high, switch contacts close, and the engine shuts down automatically.**

**THE MANUFACTURER RECOMMENDS THAT THE GENERATOR BE TESTED FOR ADEQUATE COOLING.**

### **3.5 INSTALLATION CHECKLIST**

#### **◆ LOCATION AND SUPPORT**

---

- Generator is properly located.
- Generator is properly supported.
- Generator is properly restrained.

#### **◆ GENERATOR COMPARTMENT**

---

- Compartment construction is proper.
- Holes/Openings are vapor-sealed.
- Compartment size is correct.
- Compartment is vapor-sealed.
- Sound insulation is correct.
- Floor cutouts are properly completed.

#### **◆ COOLING AND VENTILATING AIR**

---

- Airflow is adequate.
- Air inlet opening is correct.
- Compensate for restrictions.
- Check that installation has been tested.

#### **◆ DIESEL FUEL SYSTEM**

---

- Fuel tank complies with all applicable codes.
- Fuel system is properly installed and checked for leaks.

#### **◆ EXHAUST SYSTEM**

---

- Exhaust system complies with all applicable codes.
- Exhaust system is properly and safely installed.

#### **◆ ELECTRICAL CONNECTIONS**

---

- Connections comply with local code requirements and all National Electrical Codes.
- Junction box is properly installed.
- Wiring meets all standards.
- All connections are correct.
- Conduit is properly installed and sealed.
- Generator is properly bonded to the vehicle.

#### **◆ BATTERY INSTALLATION**

---

- Recommended battery is installed.
- Recommended cables are installed.
- Cables are clean and tight.
- Cables are connected properly.
- Proper ventilation is provided.
- Terminals are coated with anti-corrosion grease, and terminal covers are positioned.

#### **◆ OPTIONAL ACCESSORIES**

---

- Check that remote start/stop panels (if used) are installed properly.
- Check that all other options and accessories (if used) are installed properly.

#### **◆ POST INSTALLATION TESTS**

---

- Check that all tests are completed properly.

**DATE OF INSTALLATION** \_\_\_\_\_

**NAME OF INSTALLER** \_\_\_\_\_

**SIGNATURE OF INSTALLER** \_\_\_\_\_



## 4.1 TROUBLESHOOTING GUIDE

<b>Problem</b>	<b>Cause</b>	<b>Correction</b>
The engine will not crank.	<ol style="list-style-type: none"> <li>1. System control fuse blown</li> <li>2. Loose corroded or defective battery cables</li> <li>3. Defective engine Start/Stop switch</li> <li>4. Defective starter contactor</li> <li>5. Defective starter motor</li> <li>6. Low or defective battery</li> <li>7. Defective engine control board</li> </ol>	<ol style="list-style-type: none"> <li>1. Replace fuse.</li> <li>2. Tighten, clean, or replace, as necessary.</li> <li>3. Replace Start/Stop switch.</li> <li>4. Replace contactor.</li> <li>5. Replace starter motor.</li> <li>6. Charge or replace battery.</li> <li>7. Replace control board.</li> </ol>
The engine cranks but will not start.	<ol style="list-style-type: none"> <li>1. Vehicle fuel shutoff valve closed</li> <li>2. Out of fuel</li> <li>3. Defective fuel solenoid (FS)</li> <li>4. Defective fuel pump (FP)</li> <li>5. Open #14 wire from engine control board</li> <li>6. Plugged fuel filter or fuel line</li> <li>7. Engine mechanical parts failure</li> <li>8. Defective engine control board</li> </ol>	<ol style="list-style-type: none"> <li>1. Open valve, if so equipped.</li> <li>2. Replenish fuel.</li> <li>3. Replace solenoid.</li> <li>4. Repair or replace fuel pump.</li> <li>5. Check connections and insulation of #14 wires.</li> <li>6. Clean or replace fuel filter or line.</li> <li>7. Repair or replace parts.</li> <li>8. Replace control board.</li> </ol>
The engine starts hard and runs rough.	<ol style="list-style-type: none"> <li>1. Plugged or damaged air filter</li> <li>2. Defective fuel pump (FP)</li> <li>3. Plugged fuel filter or fuel line</li> <li>4. Water in fuel</li> <li>5. Improper preheat</li> </ol>	<ol style="list-style-type: none"> <li>1. Check, clean, or replace, as needed.</li> <li>2. Repair or replace fuel pump.</li> <li>3. Clean or replace fuel filter or line.</li> <li>4. Drain fuel system and refill.</li> <li>5. Preheat unit.</li> </ol>
The engine starts, but shuts down when the Start/Stop switch is released.	<ol style="list-style-type: none"> <li>1. Low engine oil level</li> <li>2. Overheated engine</li> <li>3. Defective Start/Stop Switch on panel or remote Start/Stop</li> <li>4. Defective low-oil pressure switch</li> <li>5. Defective high-coolant temperature switch</li> <li>6. No AC output</li> <li>7. Defective engine control board</li> </ol>	<ol style="list-style-type: none"> <li>1. Check oil and add oil, as needed.</li> <li>2. Check cooling system for leaks.</li> <li>3. Disconnect Remote Harness Check/Replace Start/Stop Switch</li> <li>4. Replace pressure switch.</li> <li>5. Replace temperature switch.</li> <li>6. Contact an Authorized Service Dealer</li> <li>7. Replace control board.</li> </ol>
The Start/Stop switch is set to Stop, but the engine continues to run.	<ol style="list-style-type: none"> <li>1. Defective Start/Stop switch</li> <li>2. Open/Disconnected #18 wire between Start/Stop switch and engine control board</li> <li>3. Open/Disconnected #0 wire between Start/Stop switch and engine control board</li> <li>4. Defective engine control board</li> </ol>	<ol style="list-style-type: none"> <li>1. Replace switch.</li> <li>2. Reconnect or close wire.</li> <li>3. Reconnect or close wire.</li> <li>4. Replace control board.</li> </ol>
There is no AC output from the generator.	<ol style="list-style-type: none"> <li>1. Main-line circuit breaker open</li> <li>2. Fault with vehicle circuit breaker and/or fuses</li> <li>3. Generator internal failure</li> </ol>	<ol style="list-style-type: none"> <li>1. Reset line breaker to ON (or CLOSED).</li> <li>2. Reset and replace, if necessary.</li> <li>3. Contact an Authorized Service Dealer.</li> </ol>

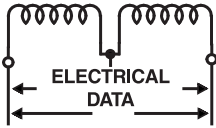

## Section 5 – Electrical Data

### Recreational Vehicle Generator

#### Electrical Schematic – 120/240 VAC Output– Drawing No. 0G7332-C

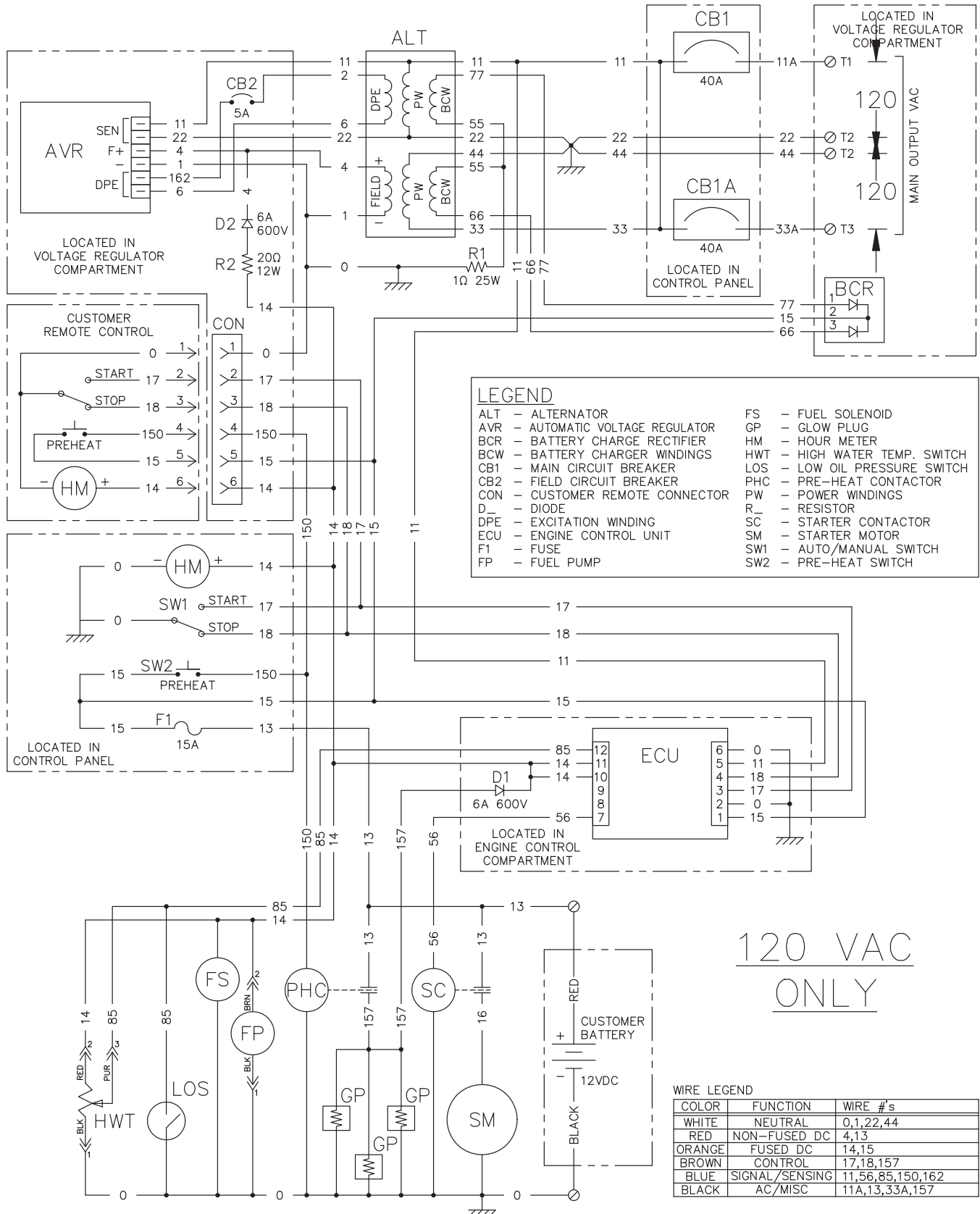



## Section 5 – Electrical Data

### Recreational Vehicle Generator Electrical Schematic – 120/240 VAC Output – Drawing No. 0G7332-C

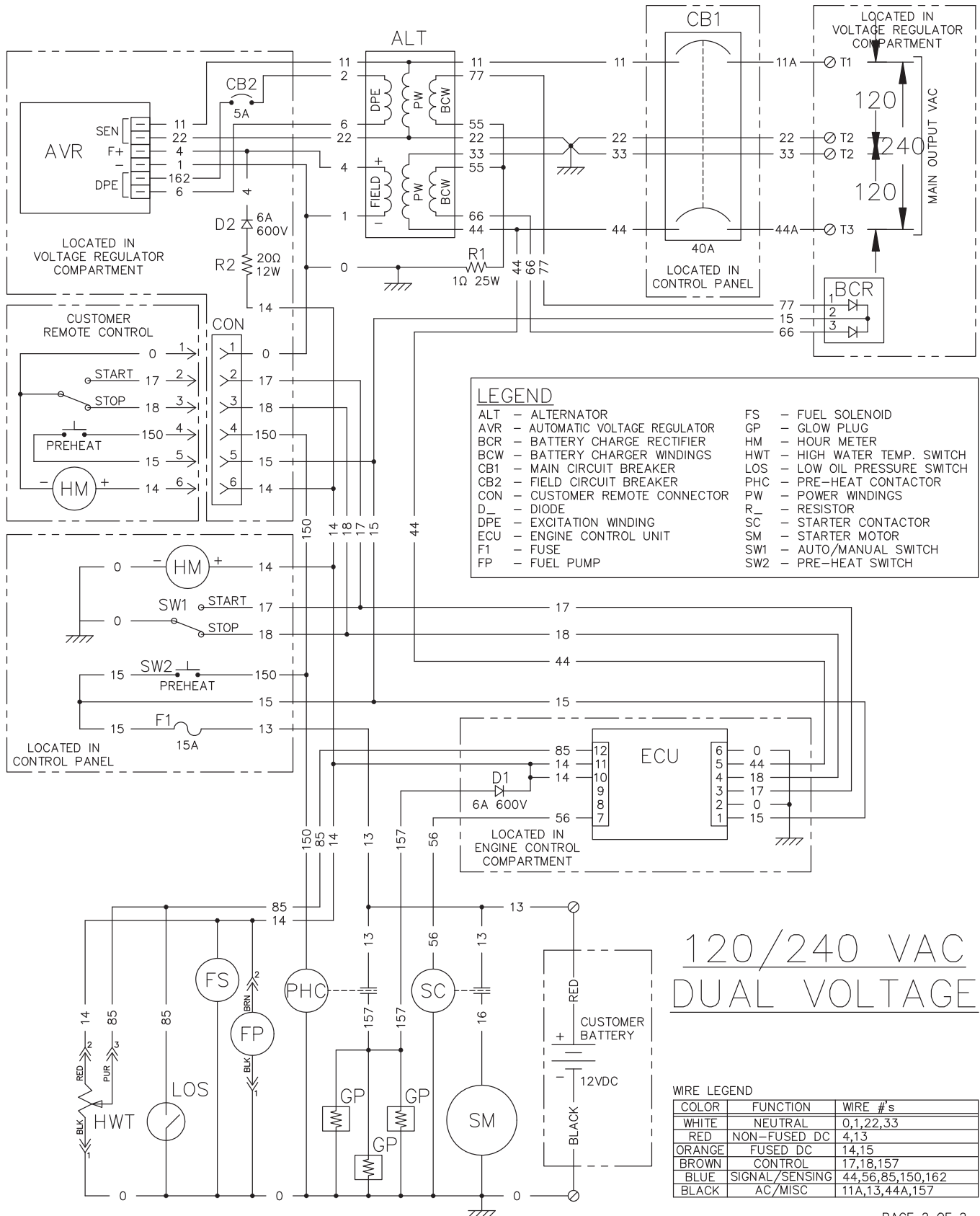
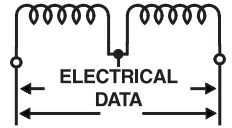



**Section 5 – Electrical Data**  
**Recreational Vehicle Generator**  
**Wiring Diagram 120 VAC- Drawing No. - 0G7333-D (Page 2 of 4)**

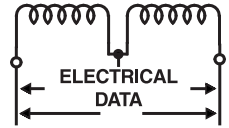

NOTE: ALL WIRES 18 AWG  
 300V UL LISTED UNLESS  
 SHOWN OTHERWISE  
 \_\_\_\_\_ AWG SIZE  
 11A, 22, 33A, & 44 TO TS  
 ARE 600V UL LISTED

**COMPONENTS LOCATED IN CONTROL PANEL**

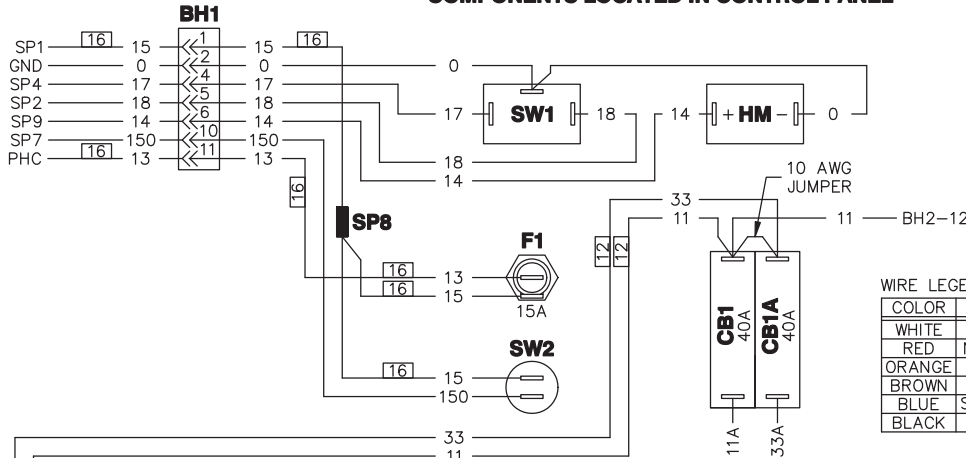

**WIRE LEGEND**

COLOR	FUNCTION	WIRE #'s
WHITE	NEUTRAL	0,1,22,44
RED	NON-FUSED DC	4,13
ORANGE	FUSED DC	14,15
BROWN	CONTROL	17,18   157 (18 awg)
BLUE	SIGNAL/SENSING	11,56,85,150,162
BLACK	AC/MISC	11A,33A   13,157 (10 awg)

**COMPONENTS LOCATED IN VOLTAGE REGULATOR COMPARTMENT**

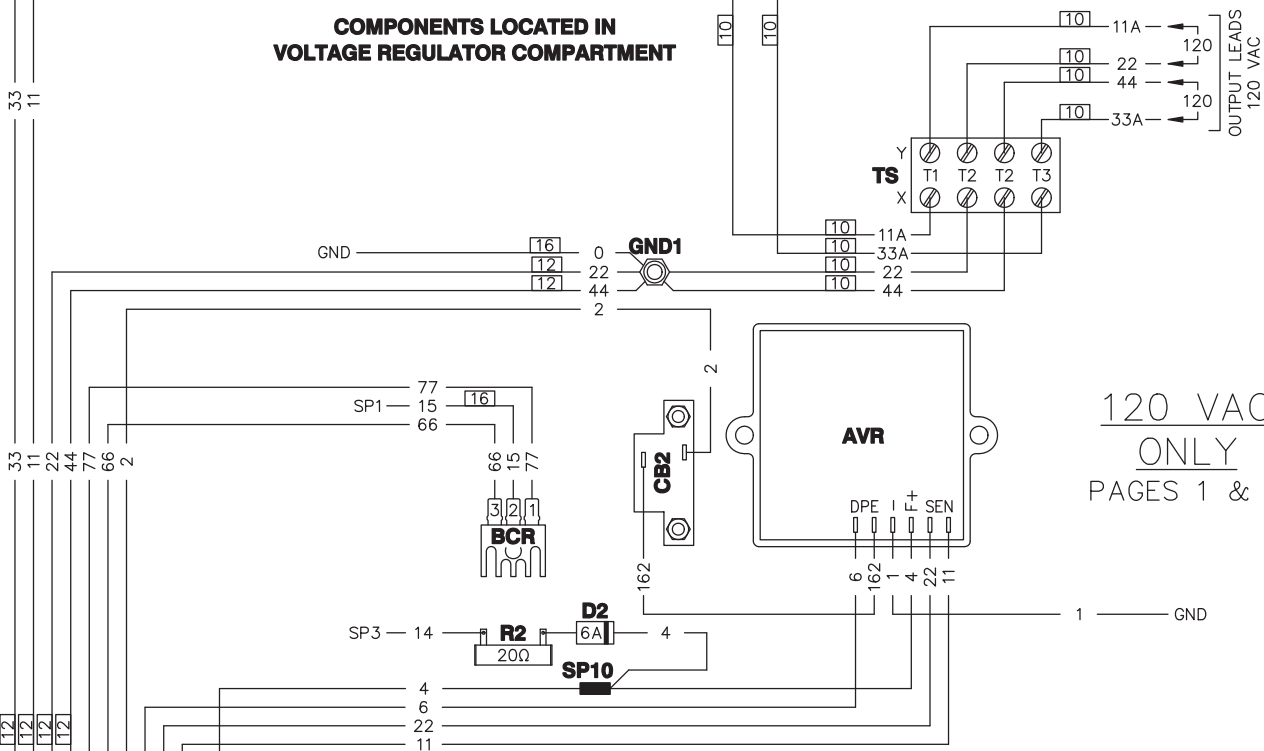

**120 VAC  
 ONLY**  
 PAGES 1 & 2

**ALTERNATOR CONNECTIONS**

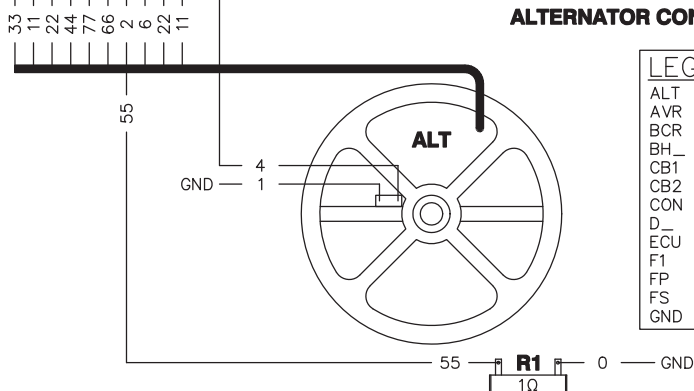

**LEGEND**

ALT - ALTERNATOR	GP - GLOW PLUG
AVR - AUTOMATIC VOLTAGE REGULATOR	HM - HOUR METER
BCR - BATTERY CHARGE RECTIFIER	HWT - HIGH WATER TEMP. SWITCH
BH_ - BULKHEAD CONNECTOR	LOS - LOW OIL PRESSURE SWITCH
CB1 - MAIN CIRCUIT BREAKER	PHC - PRE-HEAT CONTACTOR
CB2 - FIELD CIRCUIT BREAKER	R_ - RESISTOR
CON - CUSTOMER REMOTE CONNECTOR	SC - STARTER CONTACTOR
D_ - DIODE	SM - STARTER MOTOR
ECU - ENGINE CONTROL UNIT	SP_ - SPLICE
F1 - FUSE	SW1 - AUTO/MANUAL SWITCH
FP - FUEL PUMP	SW2 - PRE-HEAT SWITCH
FS - FUEL SOLENOID	TS - TERMINAL STRIP
GND - GROUND	

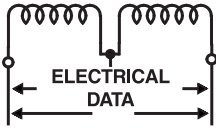

**Section 5 – Electrical Data**

**Recreational Vehicle Generator**

**Wiring Diagram 120/240 Dual Voltage– Drawing No. - 0G7333-D (Page 3 of 4)**

120/240 VAC  
DUAL VOLTAGE  
PAGES 3 & 4

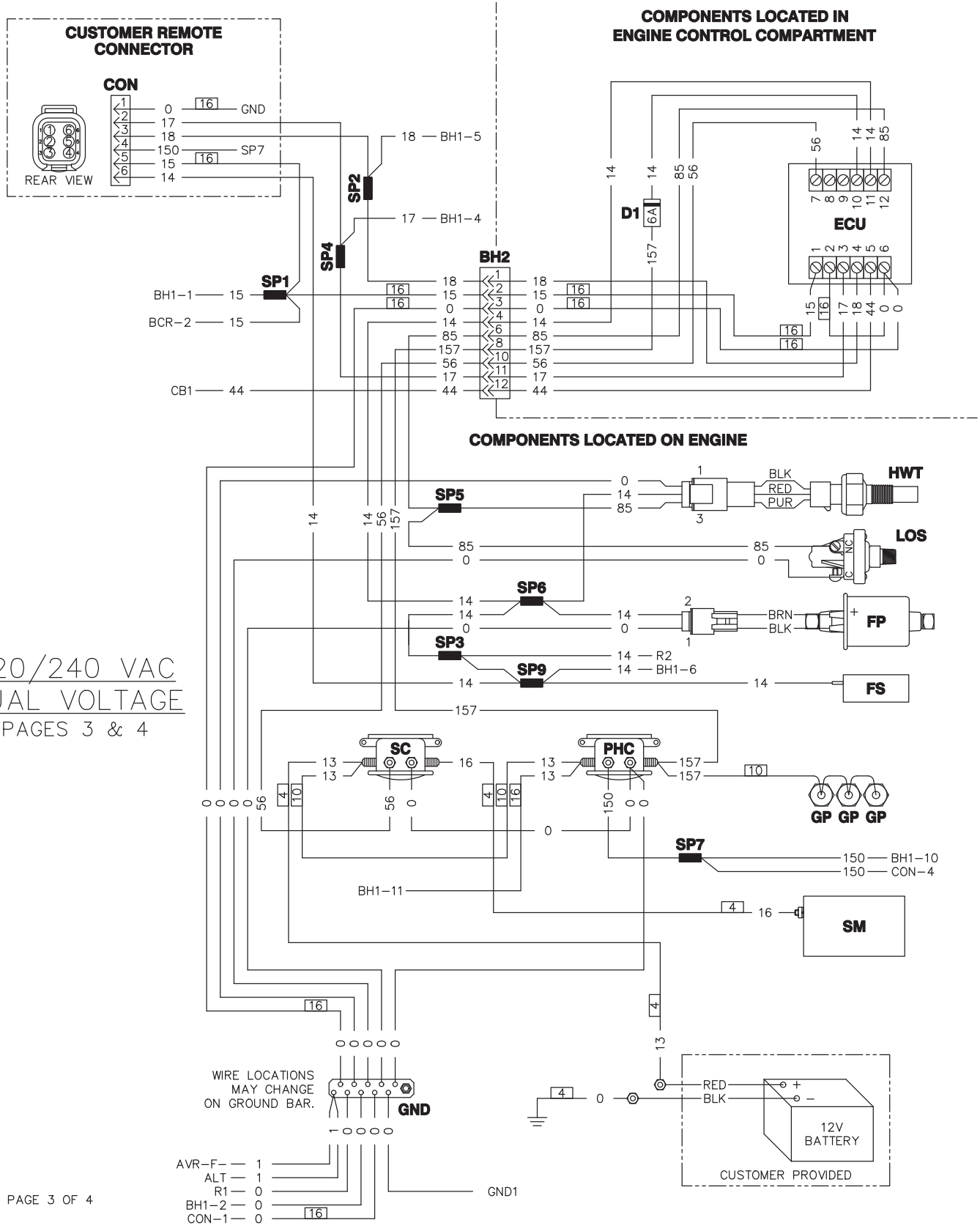

Section 5 – Electrical Data

Recreational Vehicle Generator

Wiring Diagram 120 VAC- Drawing No. - 0G7333-D (Page 4 of 4)

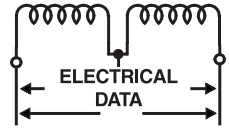

COMPONENTS LOCATED IN CONTROL PANEL

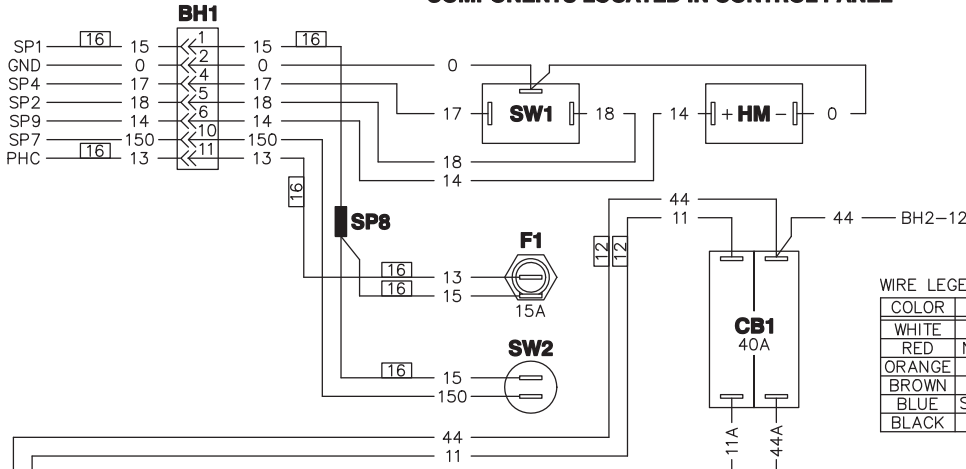

NOTE: ALL WIRES 18 AWG 300V UL LISTED UNLESS SHOWN OTHERWISE  
 11A, 22, 33, & 44A TO TS ARE 600V UL LISTED

WIRE LEGEND

COLOR	FUNCTION	WIRE #'s
WHITE	NEUTRAL	0,1,22,33
RED	NON-FUSED DC	4,13
ORANGE	FUSED DC	14,15
BROWN	CONTROL	17,18   157 (18 awg)
BLUE	SIGNAL/SENSING	44,56,85,150,162
BLACK	AC/MISC	11A,44A   13,157 (10 awg)

COMPONENTS LOCATED IN VOLTAGE REGULATOR COMPARTMENT

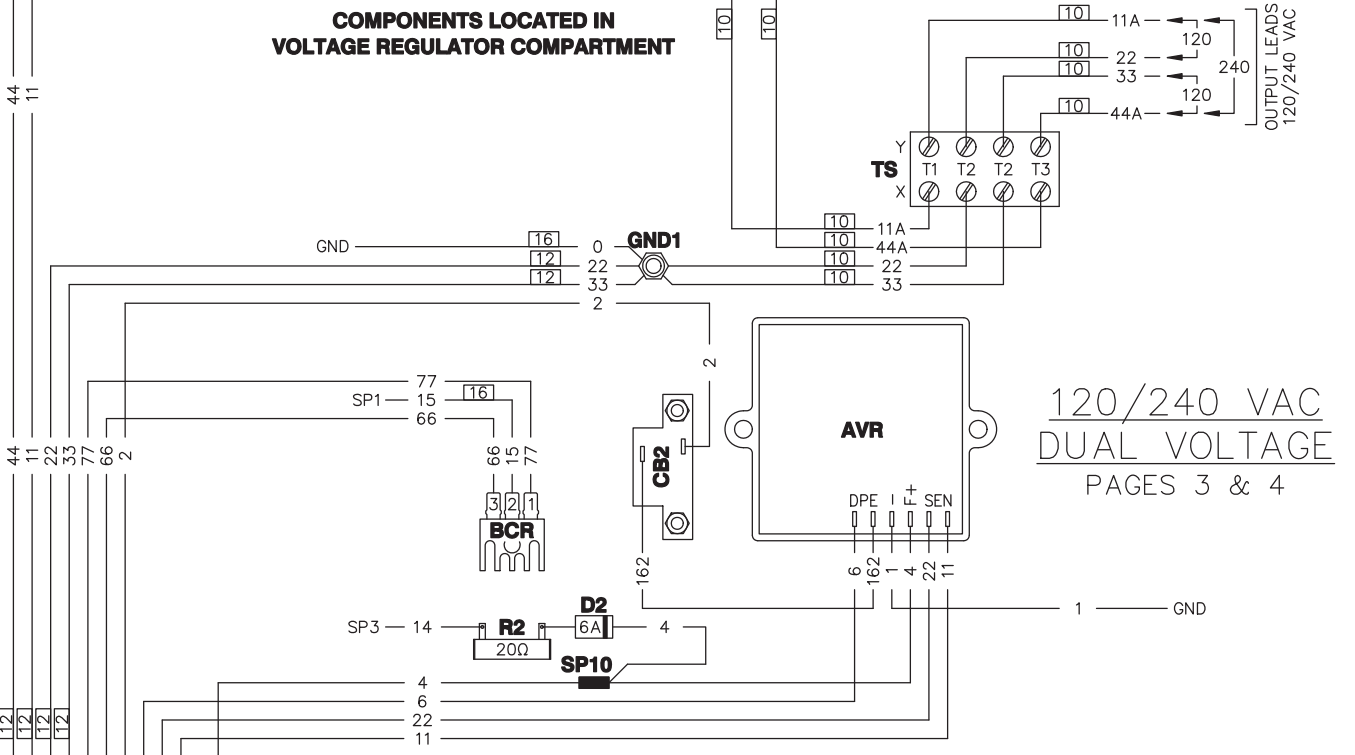

120/240 VAC  
 DUAL VOLTAGE  
 PAGES 3 & 4

ALTERNATOR CONNECTIONS

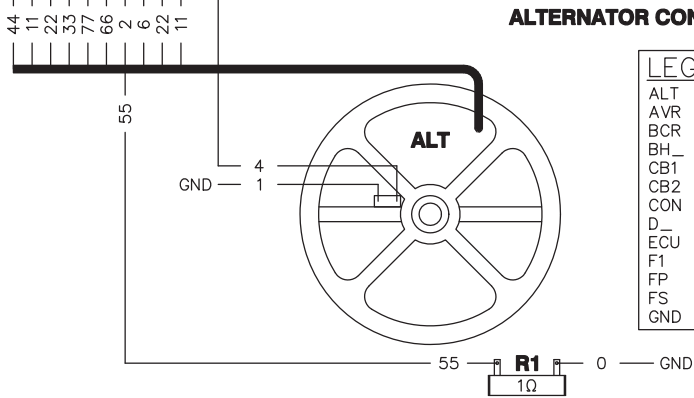

LEGEND

ALT - ALTERNATOR	GP - GLOW PLUG
AVR - AUTOMATIC VOLTAGE REGULATOR	HM - HOUR METER
BCR - BATTERY CHARGE RECTIFIER	HWT - HIGH WATER TEMP. SWITCH
BH - BULKHEAD CONNECTOR	LOS - LOW OIL PRESSURE SWITCH
CB1 - MAIN CIRCUIT BREAKER	PHC - PRE-HEAT CONTACTOR
CB2 - FIELD CIRCUIT BREAKER	R - RESISTOR
CON - CUSTOMER REMOTE CONNECTOR	SC - STARTER CONTACTOR
D - DIODE	SM - STARTER MOTOR
ECU - ENGINE CONTROL UNIT	SP - SPLICE
F1 - FUSE	SW1 - AUTO/MANUAL SWITCH
FP - FUEL PUMP	SW2 - PRE-HEAT SWITCH
FS - FUEL SOLENOID	TS - TERMINAL STRIP
GND - GROUND	

## Section 6 – Exploded Views and Parts Lists

### Recreational Vehicle Generator

Engine, Alternator Drive and Starter Assembly – Drawing No. 0G7350-B

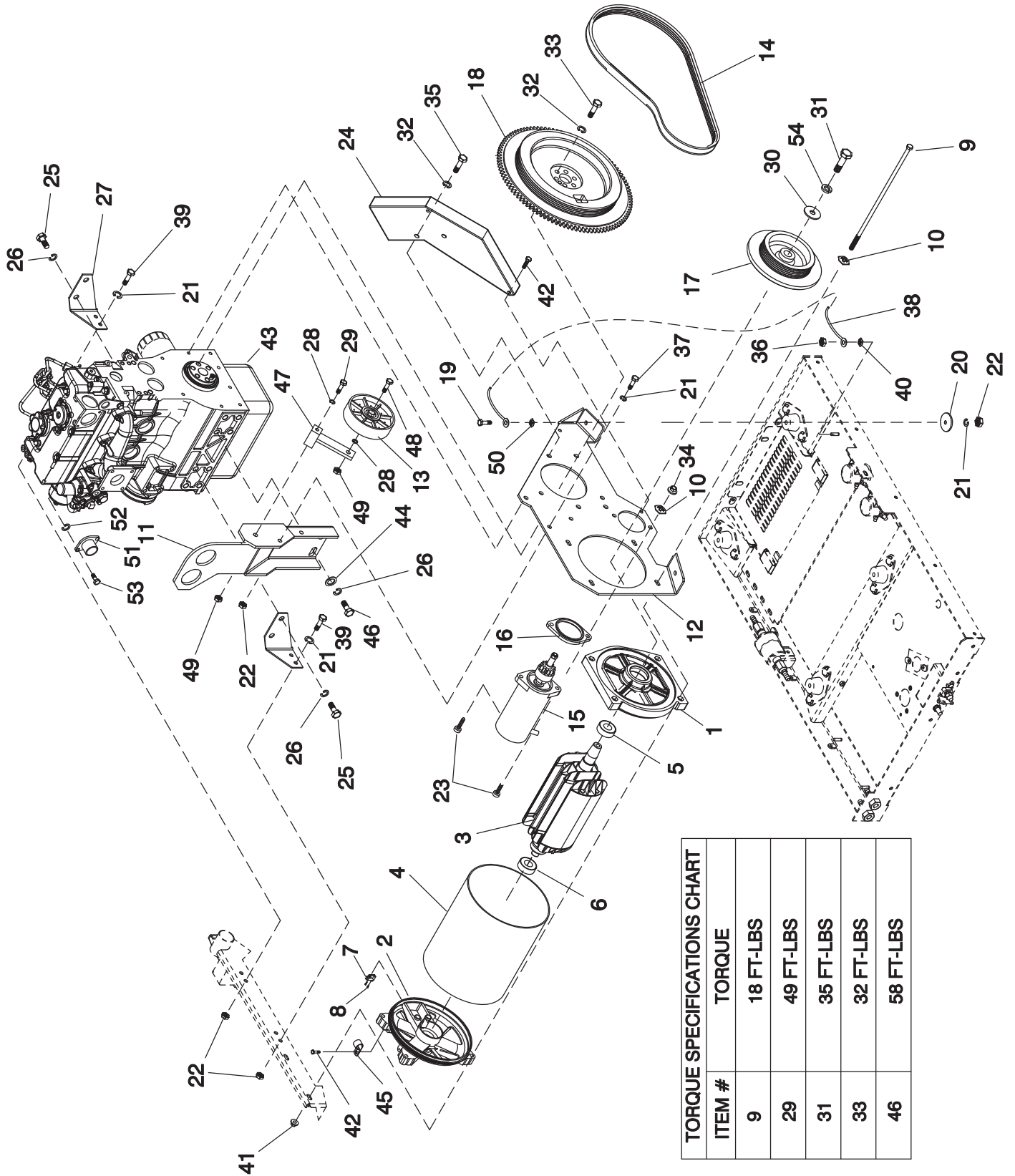

TORQUE SPECIFICATIONS CHART	
ITEM #	TORQUE
9	18 FT-LBS
29	49 FT-LBS
31	35 FT-LBS
33	32 FT-LBS
46	58 FT-LBS

## Section 6 – Exploded Views and Parts Lists

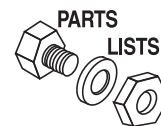

### Recreational Vehicle Generator Engine, Alternator Drive and Starter Assembly – Drawing No. 0G7350-B

ITEM	PART NO.	QTY.	DESCRIPTION
1	0C5598	1	BEARING CARRIER FRONT
2	0C9674	1	BEARING CARRIER UPPER
3	0C6055H	1	ROTOR ASSEMBLY
4	0C6054H	1	STATOR ASSEMBLY
5	031971	1	BEARING #6205 2NSE C3 E SRI2 S
6	073159	1	BALL BEARING
7	066386	1	BRUSH HOLDER
8	066849	2	SCREW HHTT M5-0.8 X 16
9	0C6862	4	SCREW HHC M8-1.25 X 324 G8.8
10	0C3168	6	WASHER LOCK SPECIAL 5/16
11	0G67720ST03	1	LUG, LIFT RV DIESEL
12	0G69990ST03	1	RAIL, RH ENGINE
13	0C8646	1	PULLEY 4.5" FLAT
14	0C5298A	1	BELT V-RIB POLYESTER
15	020692	1	STARTER MOTOR
16	0C4841	1	SPACER STARTER
17	073106G	1	PULLEY ALTERNATOR
18	0C6363	1	FLYWHEEL ASSEMBLY
19	051730	2	SCREW HHC M8-1.25 X 60 G8.8
20	071956	2	WASHER VIBRATION ISOLATOR
21	022129	8	WASHER SPLIT LK -M8
22	045771	8	NUT HEX M8-1.25 G8 CLEAR ZINC
23	040250	2	SCREW SHC 5/16-18 X 1.5 G8.8 Z
24	0C7933	1	GUARD FLYWHEEL
25	068485	4	SCREW HHC M12-1.25 X 20 G8.8
26	051769	6	WASHER LOCK M12
27	0C4537	2	ENGINE BRACKET
28	022304	2	WASHER FLAT 1/2 ZINC
29	023316	1	SCREW HHC 1/2-13 X 4 G5
30	049451	1	FENDER WASHER 7GA
31	042633	1	SCREW HHC 3/8-24 X 1 G5
32	046526	11	WASHER LOCK M10
33	052212	6	SCREW HHC M10-1.25 X 25 G8.8
34	069673J	1	NUT LOCK FLG 5/16-18
35	051756	5	SCREW HHC M10-1.5 X 20 G8.8
36	049813	1	NUT HEX M6 X 1.0 G8 YEL CHR
37	043107	2	SCREW HHC M8-1.25 X 25 G8.8
38	0C2417A	1	EARTH STRAP
39	039253	4	SCREW HHC M8-1.25 X 20 G8.8
40	0A1658	1	WASHER LOCK SPECIAL 1/4"
41	067989	4	NUT HEX FL WHIZ M8-1.25
42	0C1069	3	SCREW HHTT M6-1.0 X 8 ZYC
43	0G2321	1	ENGINE 1.1L DIESEL TIER III
44	049808	2	WASHER, FLAT M12
45	055934D	1	CLAMP VINYL 1.06 X .406 Z
46	0A7043	2	SCREW HHC M12-1.25 X 25 G8.8
47	0C8644	1	TENSIONER SE-F18
48	024426	1	SCREW HHC 1/2-13 X 1-3/4 G5
49	048705	2	NUT HEX FL 1/2-13 LOCK
50	022145	2	WASHER FLAT 5/16-M8 ZINC
51	0F4354	1	AIR INTAKE ASSEMBLY
52	022097	2	WASHER LOCK M6-1/4
53	042568	2	SCREW HHC M6-1.0 X 20 G8.8
54	022237	1	WASHER LOCK 3/8



**Section 6 – Exploded Views and Parts Lists**

**Recreational Vehicle Generator Enclosure – Drawing No. 0G7351-B**

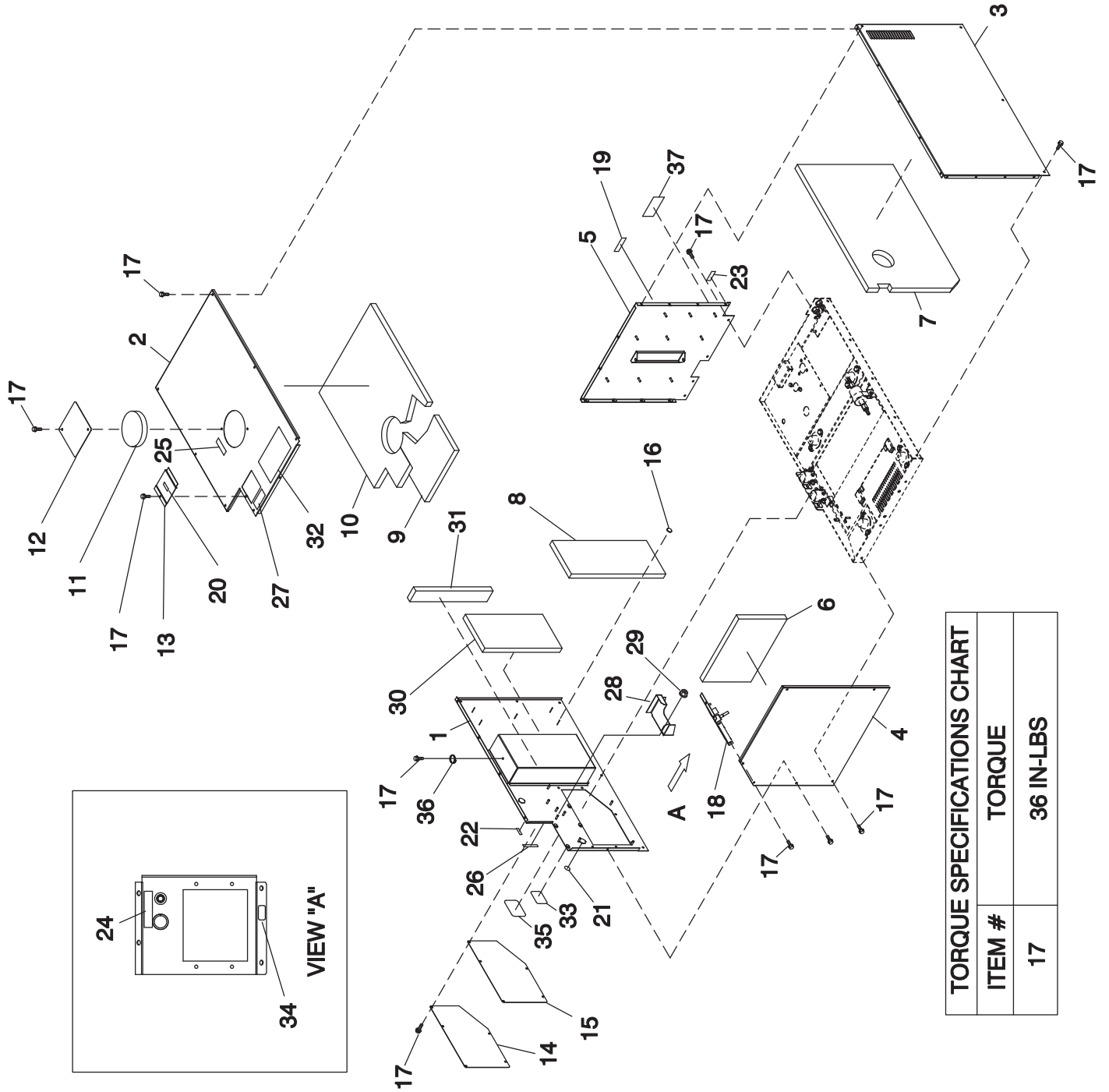

TORQUE SPECIFICATIONS CHART		
ITEM #	TORQUE	
17	36 IN-LBS	



## Section 6 – Exploded Views and Parts Lists

### Recreational Vehicle Generator Enclosure – Drawing No. 0G7351-B

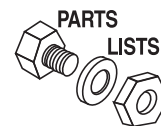

ITEM	PART NO.	QTY.	DESCRIPTION
1	0G60920ST03	1	ENCLOSURE PANEL RH,WELDMENT
2	0G72980ST03	1	ENCLOSURE PANEL, TOP
3	0G60790ST03	1	ENCLOSURE PANEL LH
4	0G60810ST03	1	ENCLOSURE PANEL,FRONT
5	0G60610ST03	1	ENCLOSURE PANEL REAR,WELDMENT
6	0G7389	1	INSULATION, FRONT PANEL
7	0G7390	1	INSULATION, LH SIDE PANEL
8	0G7391	1	INSULATION, RH SIDE PANEL
9	0G7392	1	INSULATION, TOP FRONT PANEL
10	0G7393	1	INSULATION, TOP REAR PANEL
11	0G7394	1	INSULATION, LIFT LUG COVER
12	0G73380AD12	1	COVER, ACCESS LIFT LUG
13	0G73450ST03	1	COVER, RADIATOR FILL
14	0G73470ST03	1	COVER, ELECTRICAL ACCESS
15	0C6362	1	GASKET, COVER, ELECT
16	0D7176	33	WASHER SELF LOCKING 1"DIA 12GA
17	0G4933	57	SCREW SWT 1/4-20 X 5/8 W/W
18	0C50960ST03	1	FRAME, CONTROL PANEL BLACK
19	0C7023	1	DECAL BATTERY +/-
20	0C7024	1	DECAL RADIATOR CAP
21	0C7025	1	DECAL REMOTE
22	0C7026	1	DECAL COOLANT
23	0C7027	1	DECAL FUEL RETURN/SUPPLY
24	0C7028	1	DECAL OIL FILL/LEVEL
25	0C7029	1	DECAL LIFTING LUG
26	0C7030	1	DECAL MAX HOT/MIN COLD
27	0C2340	1	DECAL, WARNING RV
28	0C64250ST03	1	SUPPORT,COOLANT TANK
29	052857	3	NUT TOP LOCK FL M6-1.0
30	0C7047A	1	FOAM,AIR DUCT FACE
31	0C7047B	1	FOAM,AIR DUCT SIDE
32	0G7285G	1	DECAL, RV 8500 WATTS DIAM. PL.
33	089463	1	DATA DECAL RV 52X90
34	098761	1	DATA ENGINE DECAL CAL.
35	0G6143	1	DECAL, U.S. TESTING RVIA/CSA
36	055934V	1	CLAMP VINYL 1.5 X .281 Z
37	0G8407	1	DECAL ULTRA LOW SULFER DIESEL

**Section 6 – Exploded Views and Parts Lists**

**Recreational Vehicle Generator  
Cooling System – Drawing No. 0G7352-A**

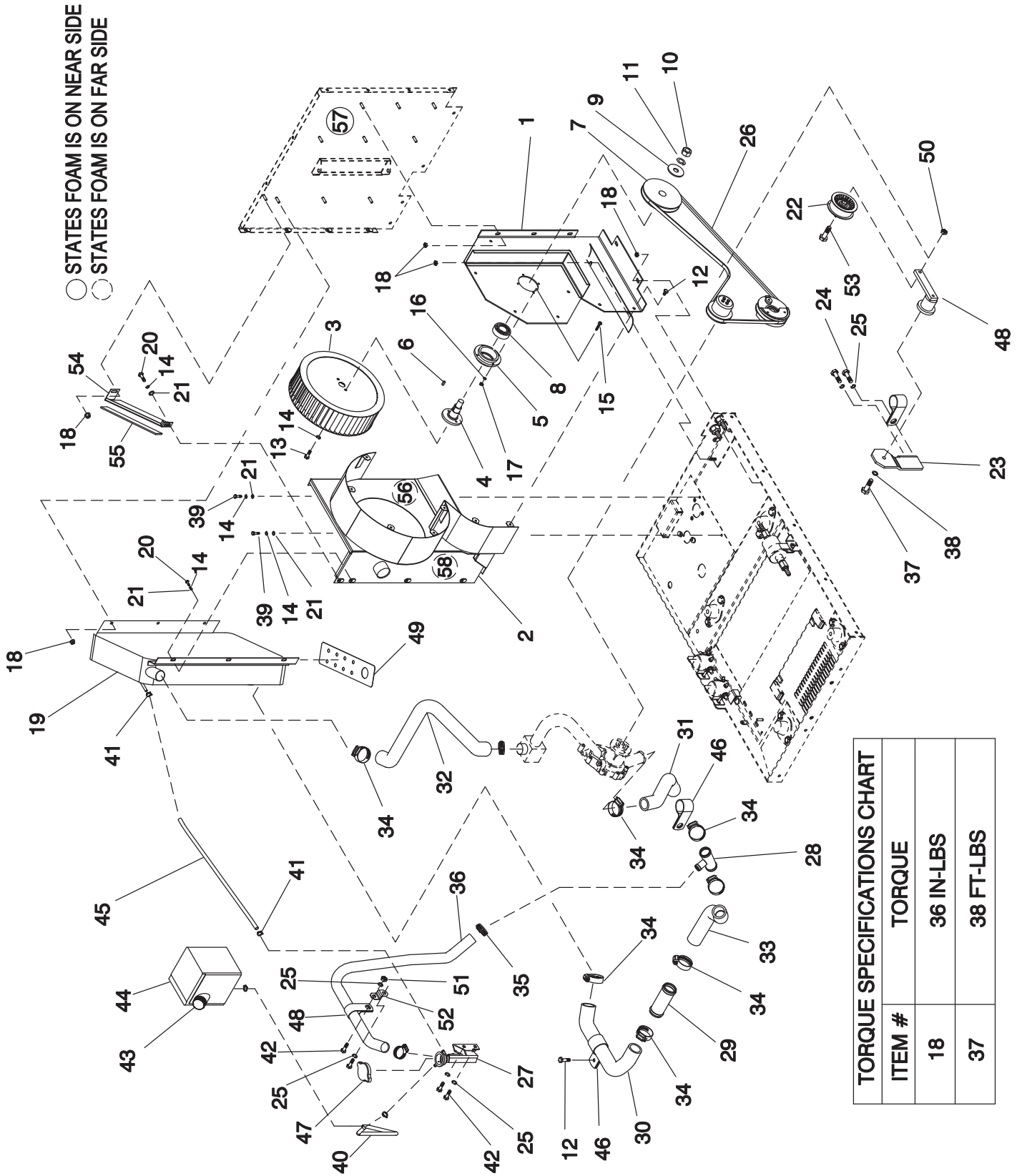

**TORQUE SPECIFICATIONS CHART**

ITEM #	TORQUE
18	36 IN-LBS
37	38 FT-LBS

## Section 6 – Exploded Views and Parts Lists

### Recreational Vehicle Generator Cooling System – Drawing No. 0G7352-A

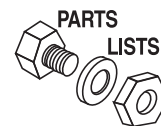

ITEM	PART NO.	QTY.	DESCRIPTION
1	0G64760ST03	1	COVER PLATE, SCRL WLDMNT
2	0G64470ST03	1	HOUSING, FAN SCROLL WLDMNT
3	0C4552	1	FAN, SQUIRREL CAGE
4	0C4554	1	SHAFT, FAN
5	0C4555	1	BEARING CARRIER
6	0C4557	1	KEY SQ 3/16 X 5/8 STEEL
7	0C4556A	1	PULLEY, FAN DIA. 114.8MM
8	0C4553	1	BEARING, 2-ROW BALL
9	049869	1	WASHER FLAT M16
10	081810	1	NUT HEX M16-1.5 G8 YEL CHR
11	070265	1	WASHER LOCK M16
12	0G4933	7	SCREW SWT 1/4-20 X 5/8 W/W
13	043146	2	SCREW HHC M6-1.0 X 10 C8.8
14	022097	8	WASHER LOCK M6-1/4
15	049815	4	SCREW HHC M5-0.8 X 16 G8.8
16	022152	4	WASHER LOCK #10
17	051716	4	NUT HEX M5-0.8 G8 CLEAR ZINC
18	052857	13	NUT TOP LOCK FL M6-1.0
19	0C4312	1	RADIATOR, 1.0L RV
20	043116	4	SCREW HHC M6-1.0 X 12 G8.8
21	022473	6	WASHER FLAT 1/4-M6 ZINC
22	0C8645	1	PULLEY 3" FLAT FLNGD
23	0C8507	1	BRACKET, TENSIONER
24	039253	2	SCREW HHC M8-1.25 X 20 C8.8
25	022129	6	WASHER LOCK M8-5/16
26	0C6549A	1	V-BELT 61.0" GREEN
27	0C5108	1	FILLER NECK ASY,RAD.
28	0C6236	1	HOSE TEE
29	0C7384	1	HOSE COUPLING
30	0C5543	1	HOSE,RADIATOR LWR
31	0C4460	1	HOSE,WATER PUMP LWR
32	0F4352	1	COOLANT HOSE, TIER 2 DIESEL
33	0C5544	1	HOSE,LWR INTERMEDIAT
34	086133A	8	CLAMP HI TORQUE 1 - 1.75
35	035473	2	CLAMP HOSE #12 .50-1.25
36	050968	1	HOSE COOL 3/4 ID 20R3 (28.3"LG)
37	059981	1	SCREW HHC M10-1.5 X 30 C10.9
38	046526	1	WASHER LOCK M10
39	047411	2	SCREW HHC M6-1.0 X 16 C8.8
40	0C7997	1	HOSE COOL 5/16" SAE 20R4 (10.6"LG)
41	0C7649	4	CLAMP HOSE .38-.87
42	042907	4	SCREW HHC M8-1.25 X 16 C8.8
43	0C5605	1	CAP,COOLANT FILL
44	0C6976	1	TANK,COOLANT OVERFL.
45	0C7997	1	HOSE COOL 5/16" SAE 20R4 (20.1"LG)
46	055934K	2	CLAMP VINYL 1.62 X .343 Z
47	0C4976	1	CAP RAD PRESSURE QP75
48	0C8643	1	TENSIONER SE18 STD
49	0C7040	1	GASKET, RADIATOR BSE
50	048705	1	NUT HEX FL 1/2-13 LOCK
51	045771	1	NUT HEX M8-1.25 G8 CLEAR ZINC
52	0C51050ST03	1	BRACKET,SUPPORT BLACK
53	024426	1	SCREW HHC 1/2-13 X 1-3/4 G5
54	0G79270ST03	1	PLATE, RADIATOR BLANKING
55	029289	A/R	TAPE ELEC 1/2 FOAM
56	0G8181	1	INSULATION, FAN WELDMNT
57	0G8182	1	INSULATION, BACK PANEL
58	0G8183	1	INSULATION, EXHAUST OUTLET

## Section 6 – Exploded Views and Parts Lists

Recreational Vehicle Generator

Fuel and Electrical Systems – Drawing No. 0G7355-A

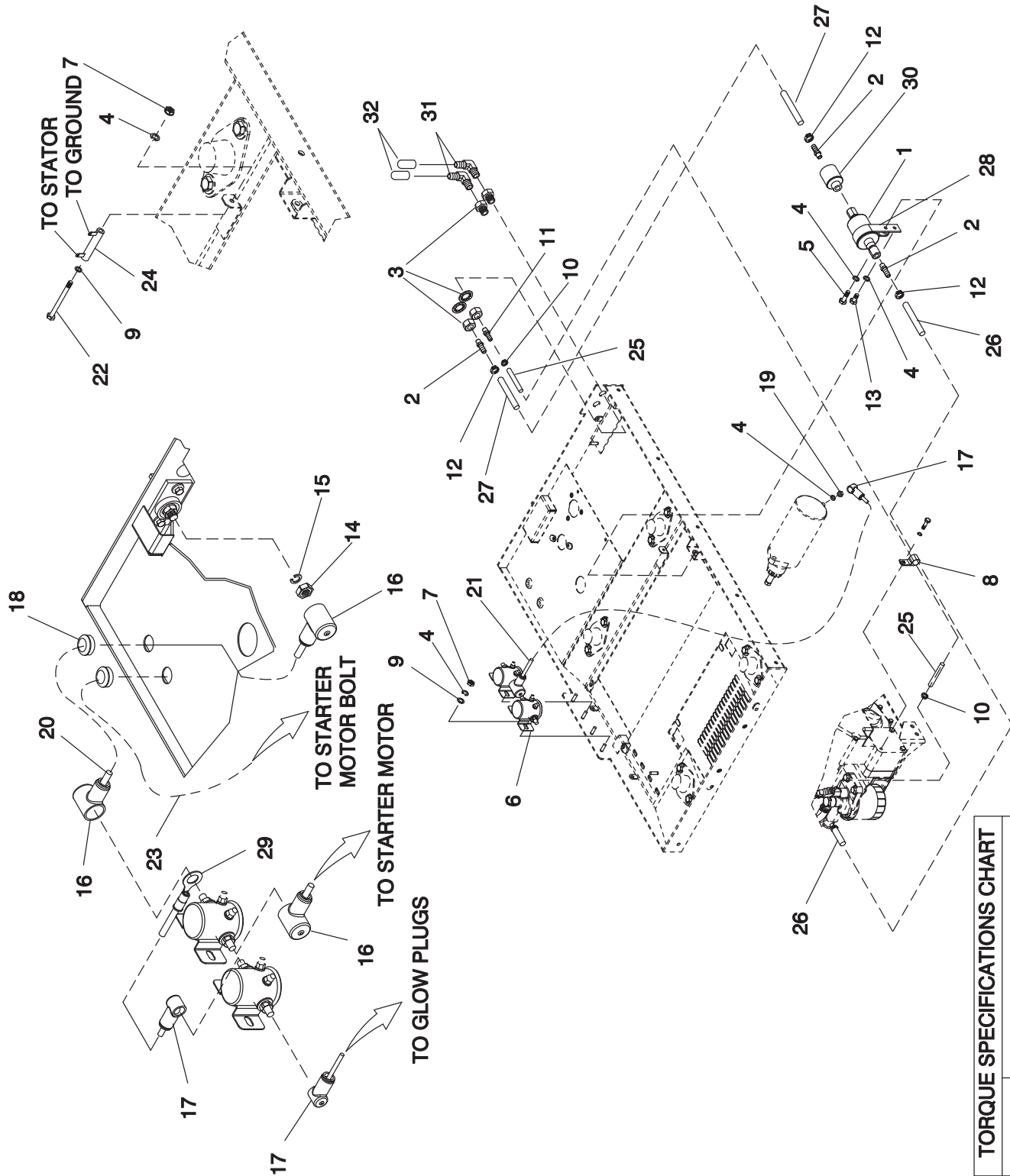

TORQUE SPECIFICATIONS CHART	
ITEM #	TORQUE
22	36 IN-LBS

**Section 6 – Exploded Views and Parts Lists**  
**Recreational Vehicle Generator**  
**Fuel and Electrical Systems – Drawing No. 0G7355-A**

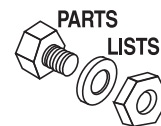

ITEM	PART NO.	QTY.	DESCRIPTION
1	0C6946A	1	FUEL PUMP ASSY REWRK
2	052219	3	BARBED STR 1/8NPT X 5/16
3	069598B	2	BULKHEAD FITTING 1/8 NPT
4	022097	7	WASHER LOCK M6-1/4
5	038750	1	SCREW HHC M6-1.0 X 30 C8.8
6	056739	2	RELAY SOLENOID 12VDC PNL MNT
7	049813	5	NUT HEX M6 X 1.0 G8 YEL CHR
8	055934D	1	CLAMP VINYL 1.06 X .406 Z
9	022473	5	WASHER FLAT 1/4-M6 ZINC
10	040173	2	CLAMP HOSE #5.5 .62-.62
11	028414A	1	BARBED STR 1/8NPT X 1/4 W/VS
12	0C7649	3	CLAMP HOSE .38-.87
13	047411	1	SCREW HHC M6-1.0 X 16 C8.8
14	0C7968	1	NUT HEX JAM 3/8-16 BRASS
15	022237	1	WASHER LOCK 3/8
16	075763	3	BOOT BATTERY CABLE
17	075763A	3	BOOT, BATTERY CABLE
18	023484F	2	BUSHING SNAP SB-1000-12
19	022127	1	NUT HEX 1/4-20 STEEL
20	0536210201	1	ASSY WIRE #13 22.00"
21	0536210197	1	ASSY WIRE #16 11.50"
22	0A2053	1	SCREW HHC M6-1.0 X 65 C8.8
23	0742600158	1	WIRE ASSY GROUND DIESEL RV
24	075234	1	RES WW LUG 1R 5% 25W
25	030340	1	HOSE 1/4 ID SAE 30R7 (41" LG)
26	0C8008	1	HOSE 5/16 SAE 30R7 (25"LG)
27	0C8008	1	HOSE 5/16 SAE 30R7 (14.76"LG)
28	0C8009	1	CLAMP, FUEL PUMP
29	0D2021H	1	WIRE ASSY, #0 (PHC-SC)
30	0D8914	1	FILTER, FUEL,1.0L RV DIESEL
31	032552	2	BARBED EL 90 5/16 X 1/8NPT
32	099827	2	CAP BLACK VINYL 5/16

**Section 6 – Exploded Views and Parts Lists**

**Recreational Vehicle Generator**

**Customer Controls Assembly – Drawing No. 0G7356-B**

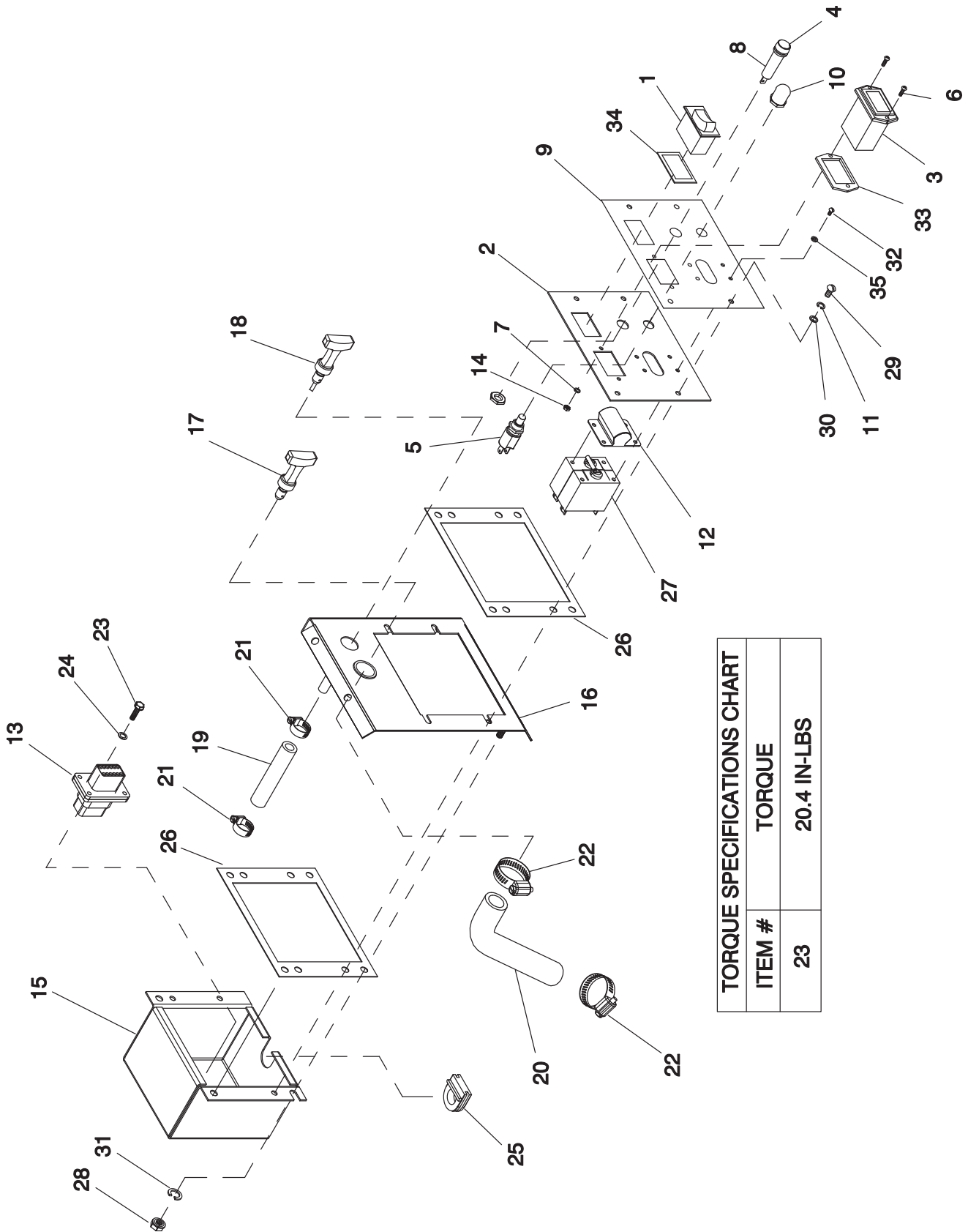

TORQUE SPECIFICATIONS CHART	
ITEM #	TORQUE
23	20.4 IN-LBS

**Section 6 – Exploded Views and Parts Lists**  
**Recreational Vehicle Generator**  
**Customer Controls Assembly – Drawing No. 0G7356-B**

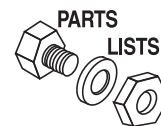

ITEM	PART NO.	QTY.	DESCRIPTION
1	080825	1	SWITCH RKR DPST
2	0C45400ST03	1	COVER ENG CONTRL BOX
3	0C1457	1	HOURMETER
4	032300	1	HOLDER FUSE
5	055920	1	SWITCH SPST SPADE PNL MNT
6	043181	2	SCREW PHM M3-0.5 X 10MM
7	022159	2	WASHER LOCK #4
8	022676	1	FUSE 15A X AGC15
9	0G7396	1	DECAL, ENGINE CONTROL BOX
10	0C7341	1	BOOT/NUT,PRE-HT SWCH
11	049226	4	WASHER LOCK M5
12	0C7340	1	BOOT, CIRCUIT BREAKER
13	0G7845	1	HARN CONTROL PANEL 1.1L G15 RV
14	051714	2	NUT HEX M3-0.5 G8 YEL CHR
15	0C44760ST03	1	BOX, ENG CONTROL RV
16	0C50960ST03	1	FRAME, CONTROL PANEL
17	0D4372	1	PLUG, OIL FILL
18	0F2664K	1	ASSY, DIPSTICK W/ TWIST 1.1L
19	0C5210	1	HOSE 3/8 ID LOW PRES OIL/WATER (5.31"LG)
20	0C5209	1	HOSE 1ID LOW PRES OIL/WATER (9.84"LG)
21	0C7649	2	CLAMP HOSE .38-.87
22	057824	2	CLAMP HOSE #16 .87-1.50
23	0C3992	4	SCREW HHTT M4-0.7 X 16 BP
24	022985	4	WASHER FLAT #6 ZINC
25	084135	1	RUBBER GROMMET,WIRES
26	0C6440	2	GASKET, ENGINE CNTRL
27	0G6873	1	CB 0040A 2P
28	049813	2	NUT HEX M6 X 1.0 G8 YEL CHR
29	076040	4	SCREW PPHM M5-0.8 X 16
30	051713	4	WASHER FLAT M5
31	022097	2	WASHER LOCK M6-1/4
32	036900	4	SCREW PPHM #6-32 X 1/4
33	0D9283	1	GASKET, HOURMETER
34	0D9391	1	GASKET ROCKER SWITCH VPS
35	022155	4	WASHER LOCK #6

**Section 6 – Exploded Views and Parts Lists**

**Recreational Vehicle Generator  
Base Frame – Drawing No. 0D2357-C**

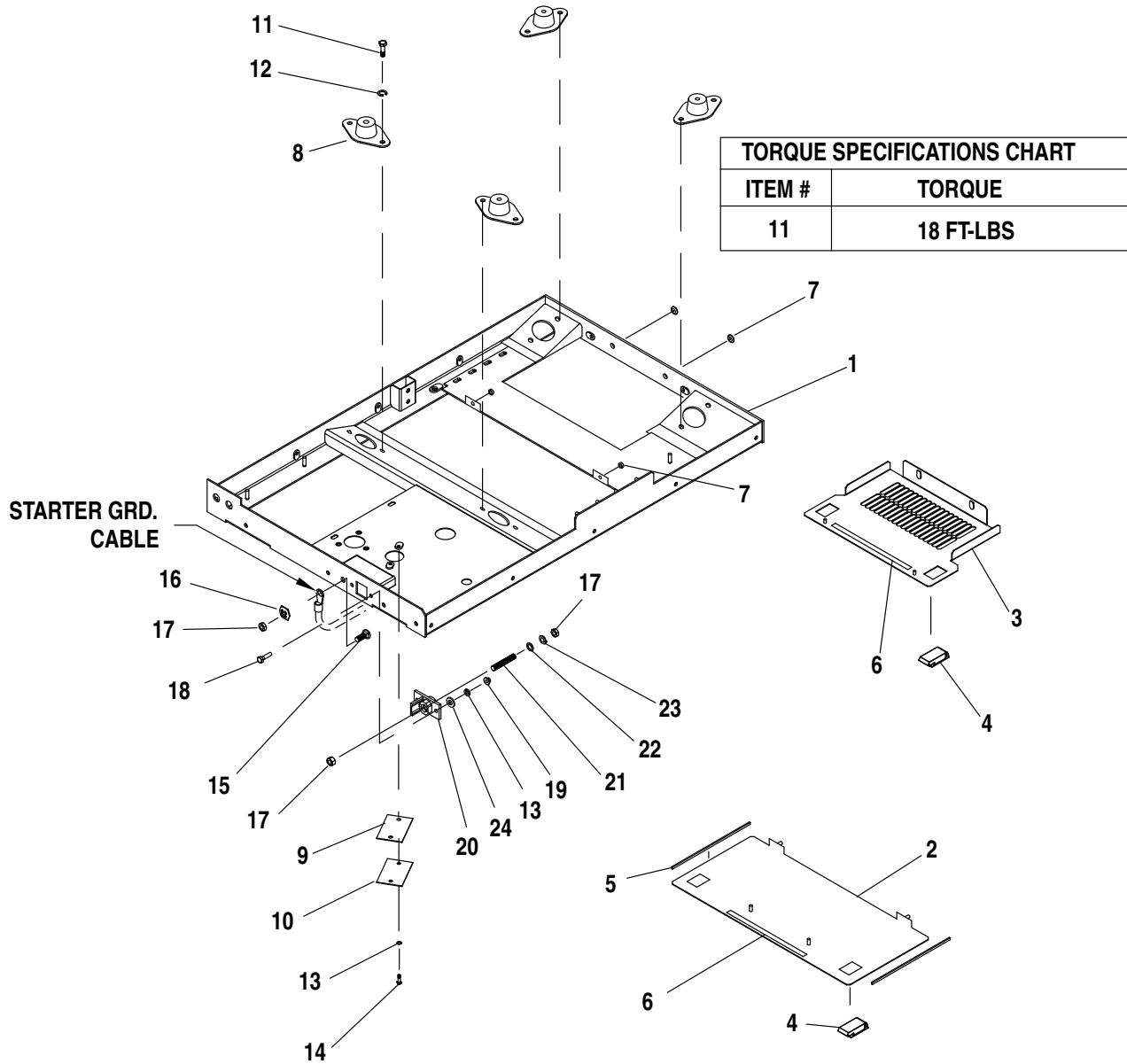

ITEM	PART NO.	QTY.	DESCRIPTION	ITEM	PART NO.	QTY.	DESCRIPTION
1	0D2126	1	Base Frame Weldment	13	022097	3	Washer, Split Lk -1/4-M6
2	0D2131	1	Door, Service Rear	14	043146	2	HHCS M6-1.00 x 10
3	0C5088	1	Door, Service Front	15	0C7561	1	Carriage Bolt 3/8 -16 x 55mm
4	0C5644	4	Slide Latch Flush	16	0A4456	1	3/8 Special Lock Washer
5	056326	2	Vinyl Trim -Black 180mm	17	0C7968	3	Hex Nut 3/8-16 Brass
6	029451	1	Rubber Tape 1/8 x 1/2" (26.6"LG)	18	047411	2	HHCS M6-1.00 x 16
7	0C7857	4	Grommet 1/8 x 13/32	19	049813	2	Nut, Hex M6.0 -1.0
8	070936E	4	Vibration Mount	20	0C5443	1	Block, Terminal Battery Post
9	0C6721	1	Gasket, Cleanout	21	0C7423	1	STUD 3/8-16 X 2-1/4 BRASS
10	0C6722	1	Plate, Cleanout	22	022131	1	WASHER FLAT 3/8-M10 ZINC
11	042907	8	HHCS M8-1.25 x 16	23	022237	1	WASHER LOCK 3/8
12	022129	8	Washer, Split Lk- M8	24	022473	2	WASHER FLAT 1/4-M6 ZINC



**Section 6 – Exploded Views and Parts Lists**  
**Recreational Vehicle Generator**  
**Electrical Enclosure Assembly – Drawing No. 0G7353-A**

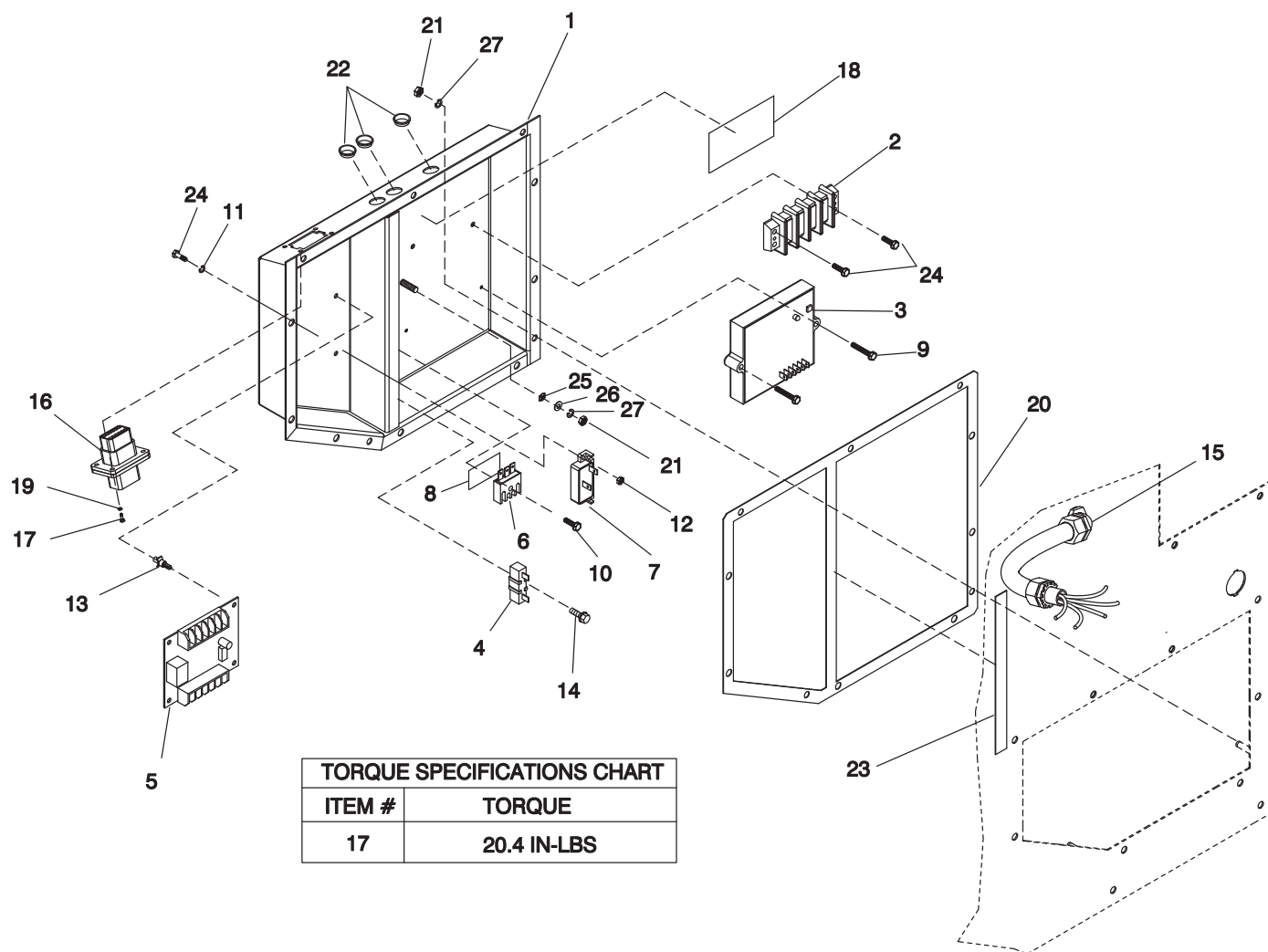
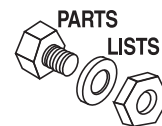

TORQUE SPECIFICATIONS CHART	
ITEM #	TORQUE
17	20.4 IN-LBS

ITEM	PART NO.	QTY.	DESCRIPTION	ITEM	PART NO.	QTY.	DESCRIPTION
1	0G71570ST03	1	WELDMENT, CONTROLLER BOX	15	0G7440	1	HARNESS, AC OUTPUT
2	071914	1	BLOCK MARATHON 4 POS 600V	16	0G7846	1	HARN ENG CONTROL PANEL 1.1L RV
3	0830490SRV	1	ASSY PCB POTTED REG W/FIN	17	0C3992	4	SCREW HHTT M4-0.7 X 16 BP
4	0F5752H	1	RES WW 20R 5% 15W QK CONN	18	0C7022	1	DECAL CUSTOMER CONNECTION
5	093642	1	ASSY MARINE CNTL BRD	19	038150	4	WASHER FLAT #8 ZINC
6	065795	1	RECTIFIER-BATT CHARG	20	0C6359	1	GASKET, ELECT ENCLOS
7	048512	1	CIRCT BRK 5 X 1 ETA 46-500-P	21	049813	6	NUT HEX M6 X 1.0 G8 YEL CHR
8	027565	A/R	TAPE UL PERMACEL P247 1.0	22	023484D	3	BUSHING SNAP SB-875-11
9	066849C	2	SCREW HHTT M5-0.8 X 30 BP	23	0C7390	1	GASKET,ELEC ENC DVDR
10	066849	1	SCREW HHTT M5-0.8 X 16	24	051787	4	SCREW HHC M4-0.7 X 16 C8.8
11	022264	2	WASHER LOCK #8-M4	25	0A1658	1	WASHER LOCK SPECIAL 1/4"
12	051715	2	NUT HEX M4-0.7 G8 YEL CHR	26	022473	1	WASHER FLAT 1/4-M6 ZINC
13	040213	4	PCB SUPPORT SNAP-IN 1/4"	27	022097	6	WASHER LOCK M6-1/4
14	0C5058	1	SCREW HHTT M3-0.5 X 12 BP	28	0G7850	1	HARN ENG 1.1L DSL RV (NOT SHOWN)

**Section 6 – Exploded Views and Parts Lists**

**Recreational Vehicle Generator**

**Intake and Exhaust System – Drawing No. 0G7354-A**

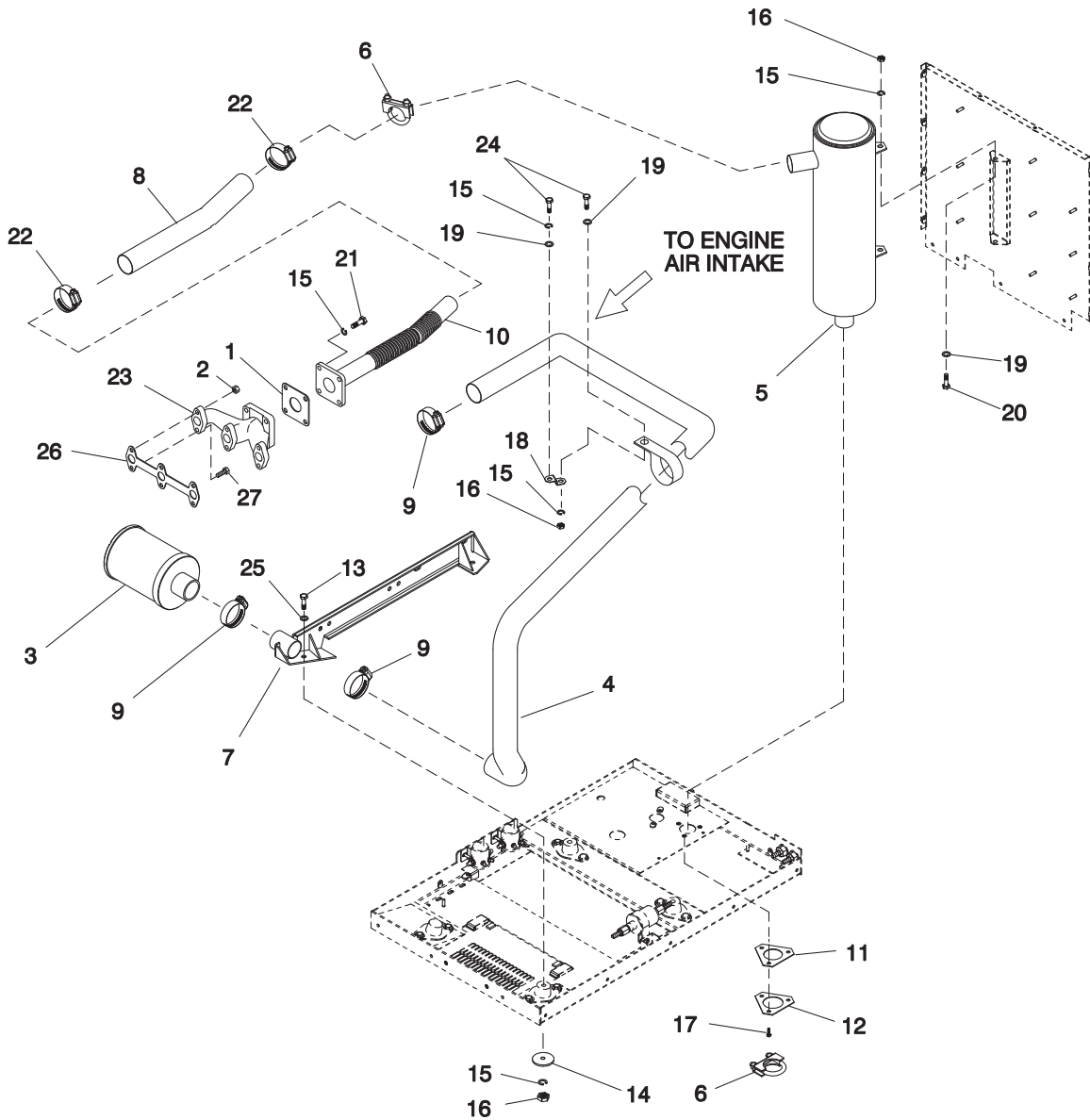

ITEM	PART NO.	QTY.	DESCRIPTION	ITEM	PART NO.	QTY.	DESCRIPTION
1	075674	1	GASKET EXHAUST ADAPTOR	15	022129	10	WASHER LOCK M8-5/16
2	0F28730173	2	NUT	16	045771	5	NUT HEX M8-1.25 G8 CLEAR ZINC
3	0E9581A	1	AIR CLEANER, 152.4MM	17	058443	3	SCREW CRIMPTITE 1/4-20 X 5/8
4	0F4366	1	HOSE, AIR INLET TIER 2 DIESEL	18	0C5105	1	BRACKET,SUPPORT
5	0C4727	1	MUFFLER, 1.0 L D, RV	19	022145	5	WASHER FLAT 5/16-M8 ZINC
6	025145	2	BOLT U 5/16-18 X 1.25 W/SADDLE	20	039253	2	SCREW HHC M8-1.25 X 20 C8.8
7	0G69970ST03	1	RAIL, ENGINE LH	21	043107	4	SCREW HHC M8-1.25 X 25 C8.8
8	0C5022	1	INSUL.,EXHAUST QP75	22	035586	2	CLAMP HOSE #20 .87-1.75
9	035685	3	CLAMP HOSE #28 1.32-2.25	23	075673	1	MANIFOLD EXHAUST
10	0C4878	1	OUTLET EXHAUST-FLEX	24	042907	2	SCREW HHC M8-1.25 X 16 C8.8
11	0C6243	1	GASKET, EXH. OUTLET	25	022145	2	WASHER FLAT 5/16-M8 ZINC
12	0C6244	1	PLATE, EXH. OUTLET	26	0709390357	1	GASKET, EXHAUST ISM
13	051730	2	SCREW HHC M8-1.25 X 60 C8.8	27	0F28730132	4	BOLT
14	071956	2	WASHER FLAT M8				

**Section 6 – Exploded Views and Parts Lists**

**Recreational Vehicle Generator  
1.0 Liter Diesel Camshaft – Drawing No. 0F6230**

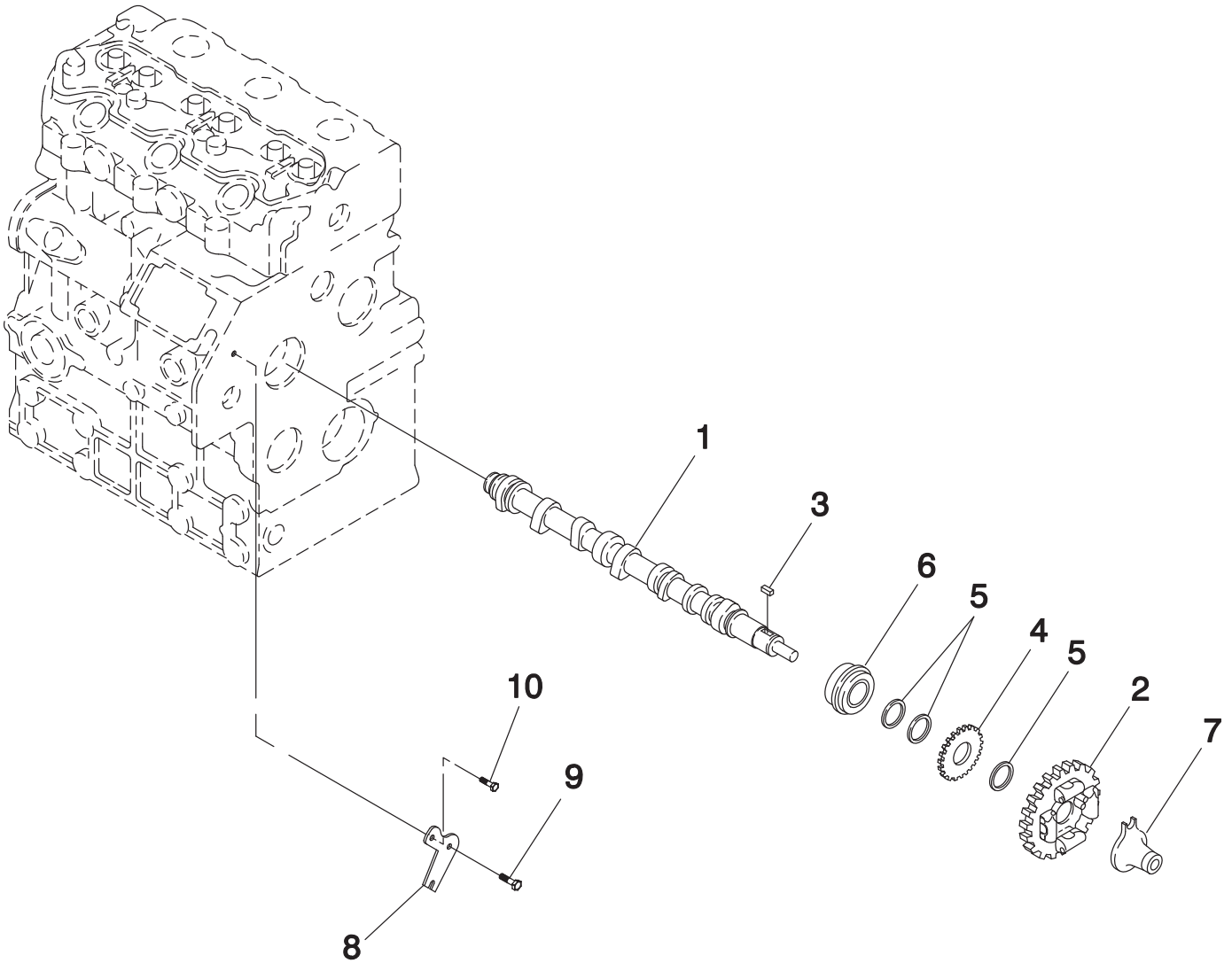
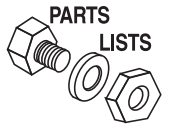

ITEM	PART NO.	QTY.	DESCRIPTION
1	0F28730164	1	CAMSHAFT ASSEMBLY
2	0709390233	1	CAMSHAFT GEAR
3	0709390195	1	KEY
4	0709390234	1	GEAR
5	0709390235	3	SPACER
6	0709390236	1	BALL BEARING
7	0709390237	1	SLIDER
8	0709390238	1	PLATE
9	0709390241	1	BOLT
10	0709390240	1	BOLT

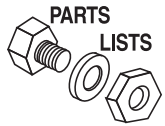

## Section 6 – Exploded Views and Parts Lists

### Recreational Vehicle Generator

#### 1.0 Liter Diesel Oil Pump – Drawing No. 0F6231

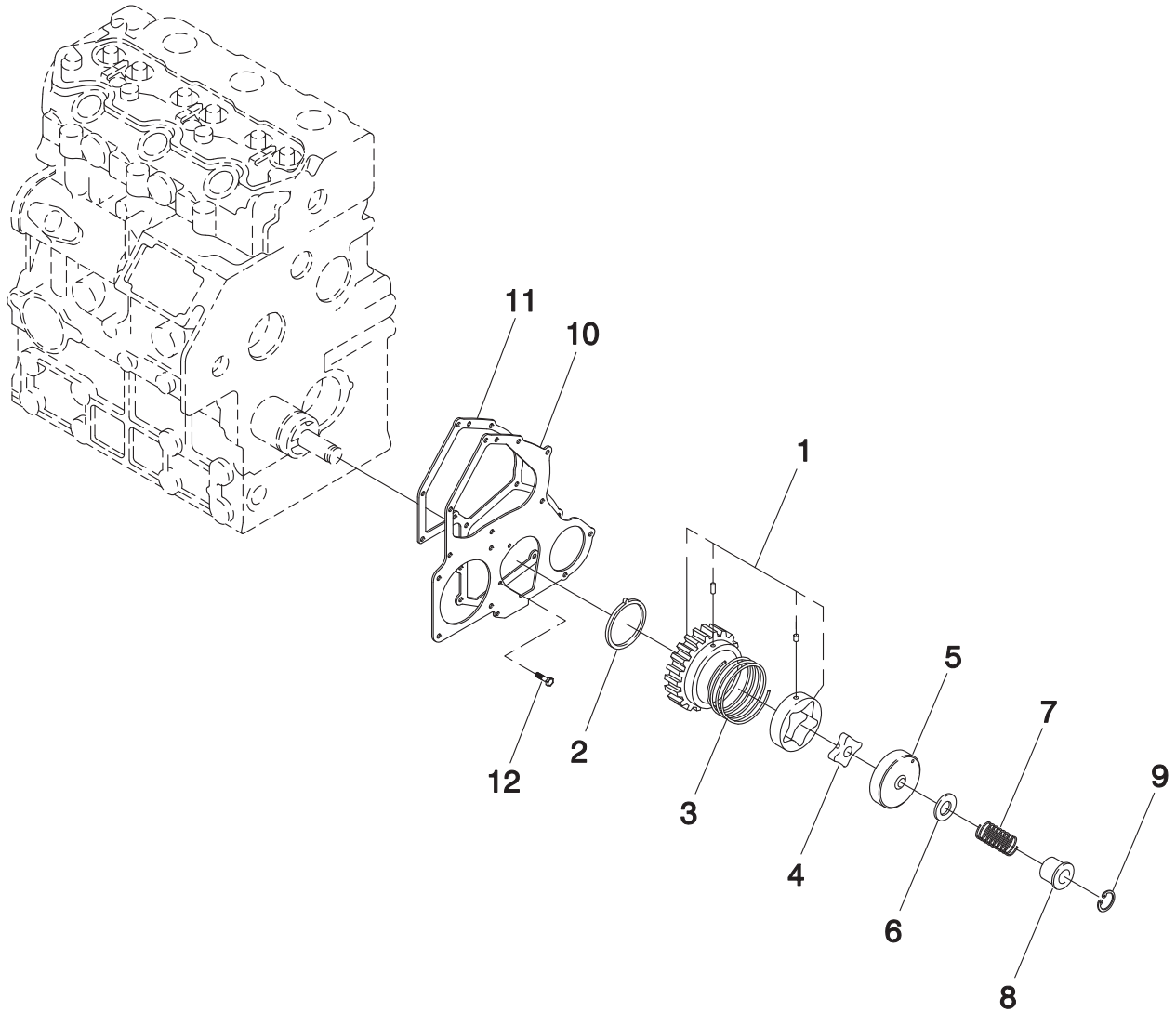

ITEM	PART NO.	QTY.	DESCRIPTION
1	0709390250	1	IDLER GEAR ASSEMBLY
2	0709390251	1	THRUST WASHER
3	0709390252	1	SPRING
4	0709390253	1	ROTOR
5	0709390254	1	OIL PUMP COVER
6	0709390255	AR	0.10MM SHIM
	0709390532	AR	0.15MM SHIM
	0709390533	AR	0.20MM SHIM
	0709390258	AR	0.50MM SHIM
7	0709390259	1	SPRING
8	0709390260	1	COLLAR
9	0709390261	1	SNAP RING
10	0709390262	1	FRONT PLATE
11	0F28730165	1	GASKET
12	0F28730166	3	BOLT

AR - AS REQUIRED

**Section 6 – Exploded Views and Parts Lists**  
**Recreational Vehicle Generator**  
**1.0 Liter Diesel Cylinder Head – Drawing No. 0G7500-A**

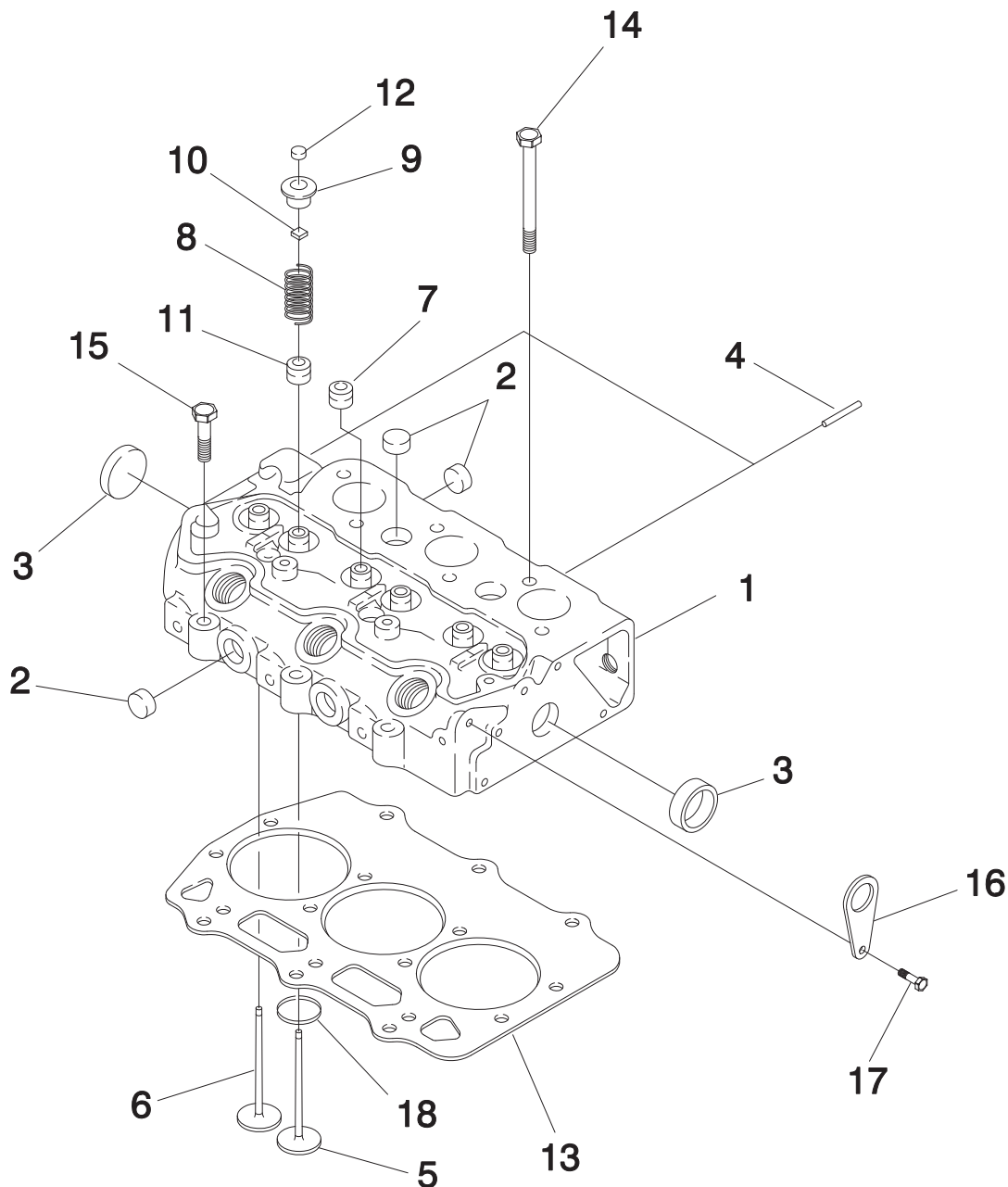
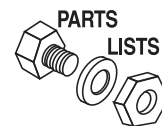

ITEM	PART NO.	QTY.	DESCRIPTION	ITEM	PART NO.	QTY.	DESCRIPTION
1	0G23210107	1	CYLINDER HEAD ASSEMBLY	12	0G23210108	6	CAP
2	0F28730119	8	SEALING CAP	13	0G23210109	1	HEAD GASKET, 1.2mm THICK
3	0F28730120	2	SEALING CAP		0G23210110	1	HEAD GASKET, 1.3mm THICK
4	0F28730121	2	STUD BOLT	14	0F28730125	11	HEAD BOLT
5	0F28730122	3	INTAKE VALVE	15	0F28730126	3	HEAD BOLT
6	0709390151	3	EXHAUST VALVE	16	0709390162	2	LIFTING EYE
7	0709390153	3	VALVE GUIDE SEAL (INTAKE)	17	0G23210111	2	BOLT
8	0709390154	6	SPRING	18	0G23210112	3	VALVE SEAT(INTAKE)
9	0709390155	6	RETAINER				
10	0709390156	12	KEY				
11	0709390152	3	VALVE GUIDE SEAL (EXHAUST)				

MM=MILLIMETER



## Section 6 – Exploded Views and Parts Lists

### Recreational Vehicle Generator

#### 1.0 Liter Diesel Engine Block – Drawing No. 0G7501-A

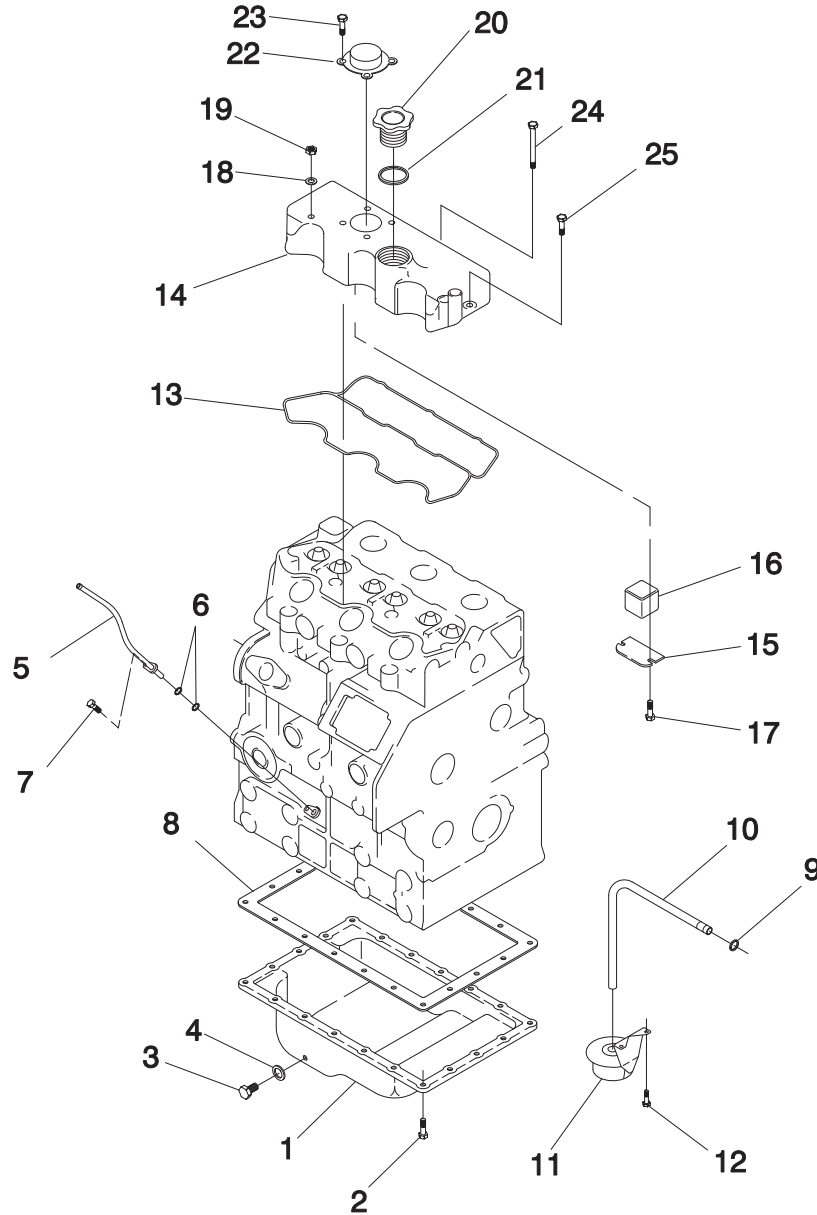

ITEM	PART NO.	QTY.	DESCRIPTION	ITEM	PART NO.	QTY.	DESCRIPTION
1	0G23210152	1	OIL PAN	14	0F28730143	1	HEAD COVER
2	0709390140	20	BOLT	15	0F28730144	1	OIL STOPPER
3	0G23210153	1	BOLT	16	0709390186	1	SCREEN
4	0F28730176	1	SEAL WASHER FOR THERMO SWITCH	17	0F28730145	4	SCREW
5	0G6451	1	DIPSTICK TUBE	18	0F28730146	3	GASKET
6	0D7124	2	O-RING	19	0F28730147	3	CAP NUT
7	0F28730117	1	BOLT	20	0709390188	1	CAP
8	0F28730114	1	GASKET, OIL PAN	21	0709390189	1	O-RING
9	0F28730167	1	O-RING	22	0F28730148	1	BREATHER VALVE
10	0709390245	1	TUBING	23	0F28730149	4	BOLT
11	0709390246	1	SUCTION FILTER	24	0F28730150	3	BOLT
12	0F28730168	2	BOLT	25	0F28730132	2	BOLT
13	0F28730142	1	GASKET				

**Section 6 – Exploded Views and Parts Lists**  
**Recreational Vehicle Generator**  
**1.0 Liter Diesel Water Pump – Drawing No. 0G7502-A**

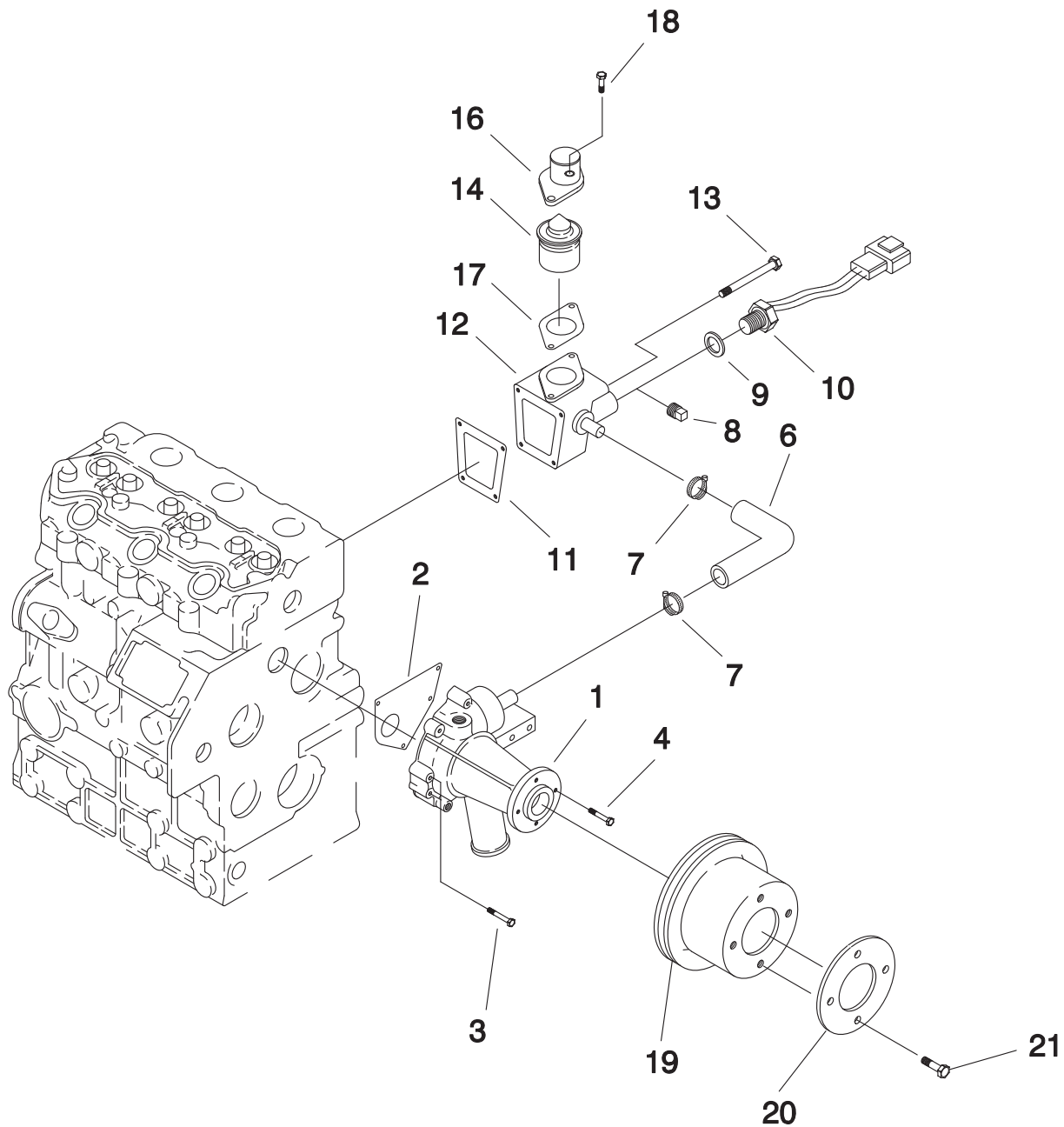
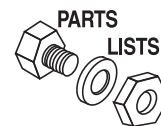

ITEM	PART NO.	QTY.	DESCRIPTION	ITEM	PART NO.	QTY.	DESCRIPTION
1	0F28730169	1	WATER PUMP ASSEMBLY	12	0G23210154	1	THERMOSTAT CASE
2	0F28730170	1	GASKET	13	0F28730180	4	BOLT
3	0F28730171	1	BOLT	14	0F28730181	1	THERMOSTAT
4	0F28730172	2	BOLT	16	0F28730183	1	THERMOSTAT COVER
6	0F28730174	1	RUBBER HOSE	17	0F28730184	1	GASKET
7	0F28730175	2	CLAMP	18	0F28730202	1	BOLT
8	0709390266	1	PLUG	19	0709390247	1	PULLY
9	0F28730176	1	SEAL WASHER	20	0F28730217	1	PLATE
10	0D2791	1	THERMO SWITCH	21	0F28730218	4	BOLT
11	0F28730178	1	GASKET				

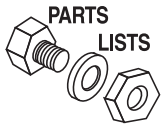

## Section 6 – Exploded Views and Parts Lists

### Recreational Vehicle Generator

#### 1.0 Liter Diesel Cylinder Block– Drawing No. 0G7503-A

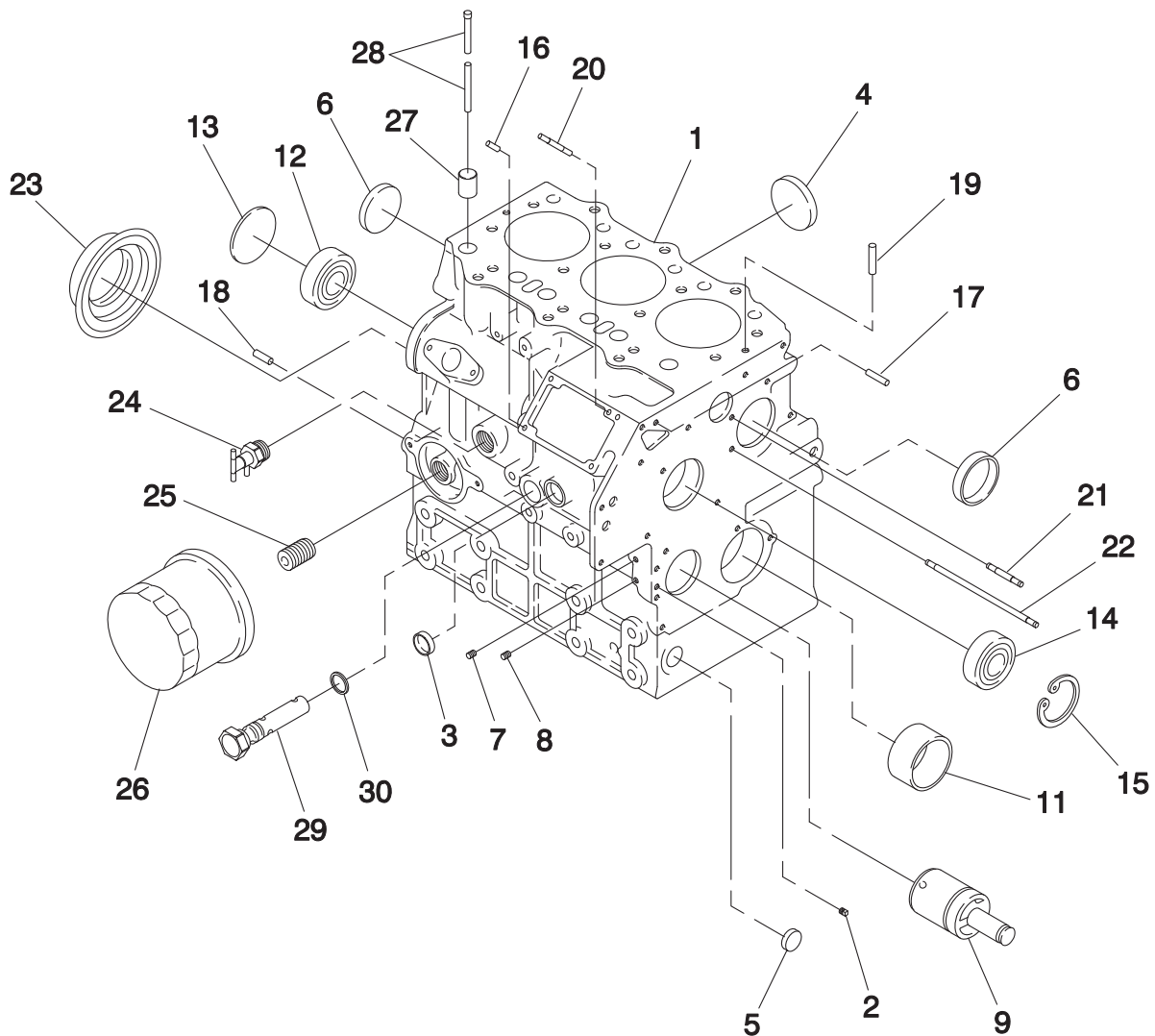

ITEM	PART NO.	QTY.	DESCRIPTION	ITEM	PART NO.	QTY.	DESCRIPTION
1	0G23210100	1	CYLINDER BLOCK	17	0709390116	2	DOWEL PIN
2	0709390104	1	BLANK PLUG	18	0709390117	2	DOWEL PIN
3	0F28730101	1	SEALING CAP	19	0709390118	2	SPRING PIN
4	0F28730102	2	SEALING CAP	20	0F28730111	2	STUD BOLT
5	0F28730103	1	SEALING CAP	21	0F28730112	1	STUD BOLT
6	0F28730104	2	SEALING CAP	22	0F28730113	1	STUD BOLT
7	0709390106	4	BLANK PLUG	23	0G23210104	1	OIL SEAL
8	0709390105	4	BLANK PLUG	24	0709390124	1	DRAIN COCK
9	0F28730105	1	COMPLETE IDLE GEAR SHAFT	25	0709390125	1	CONNECTOR
11	0G23210101	1	BUSHING – STANDARD	26	0G23210156	1	OIL FILTER
	0G23210102	1	0.25mm U.S. BUSHING	27	0G23210105	6	TAPPET
	0G23210103	1	0.50mm U.S. BUSHING	28	0G23210106	6	PUSH ROD
12	0F28730110	1	BEARING	29	0F28730115	1	RELIEF VALVE
13	0709390113	1	EXPANSION PLUG	30	0F28730219	1	O-RING
14	0709390114	1	BALL BEARING				
15	0709390131	1	SNAP RING				
16	0709390115	2	DOWEL PIN				

MM = MILLIMETER  
U.S. = UNDERSIZE



## Section 6 – Exploded Views and Parts Lists

### Recreational Vehicle Generator 1.0 Liter Diesel Rocker Arm Assembly – Drawing No. 0G7504-A

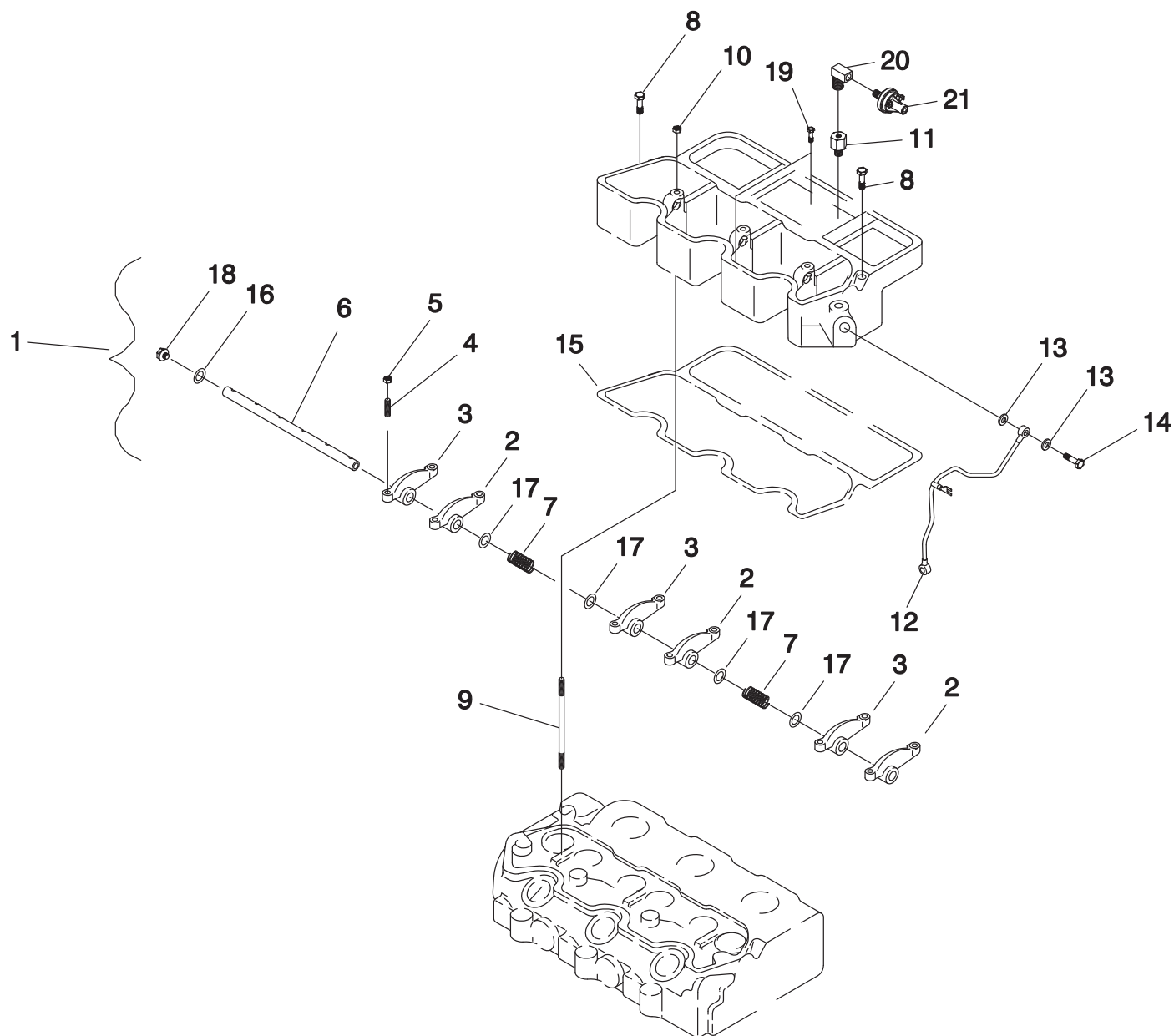
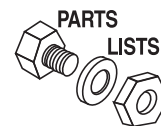

ITEM	PART NO.	QTY.	DESCRIPTION	ITEM	PART NO.	QTY.	DESCRIPTION
1	0F28730128	1	ROCKER ARM ASSEMBLY	12	0G23210132	1	OIL PIPE
2	0F28730129	3	INTAKE ROCKER ARM	13	0F28730146	4	GASKET
3	0F28730130	3	EXHAUST ROCKER ARM	14	0709390165	2	EYE BOLT
4	0709390173	6	SCREW	15	0F28730137	1	GASKET
5	0709390174	6	NUT	16	0F28730138	1	O-RING
6	0F28730131	1	ROCKER ARM SHAFT	17	0F28730139	4	SHIM
7	0709390177	2	SPRING	18	0F28730140	1	PLUG
8	0F28730132	2	BOLT	19	0F28730141	1	SCREW
9	0709390181	3	STUD BOLT	20	028916	1	90 STREET ELBOW
10	0F28730133	3	NUT	21	0A8584	1	OIL PRESSURE SWITCH
11	042574	1	ADAPTER				

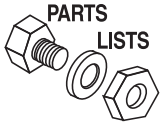

## Section 6 – Exploded Views and Parts Lists

### Recreational Vehicle Generator

#### 1.0 Liter Diesel Crankshaft, Piston and Flywheel – Drawing No. 0G7505-A

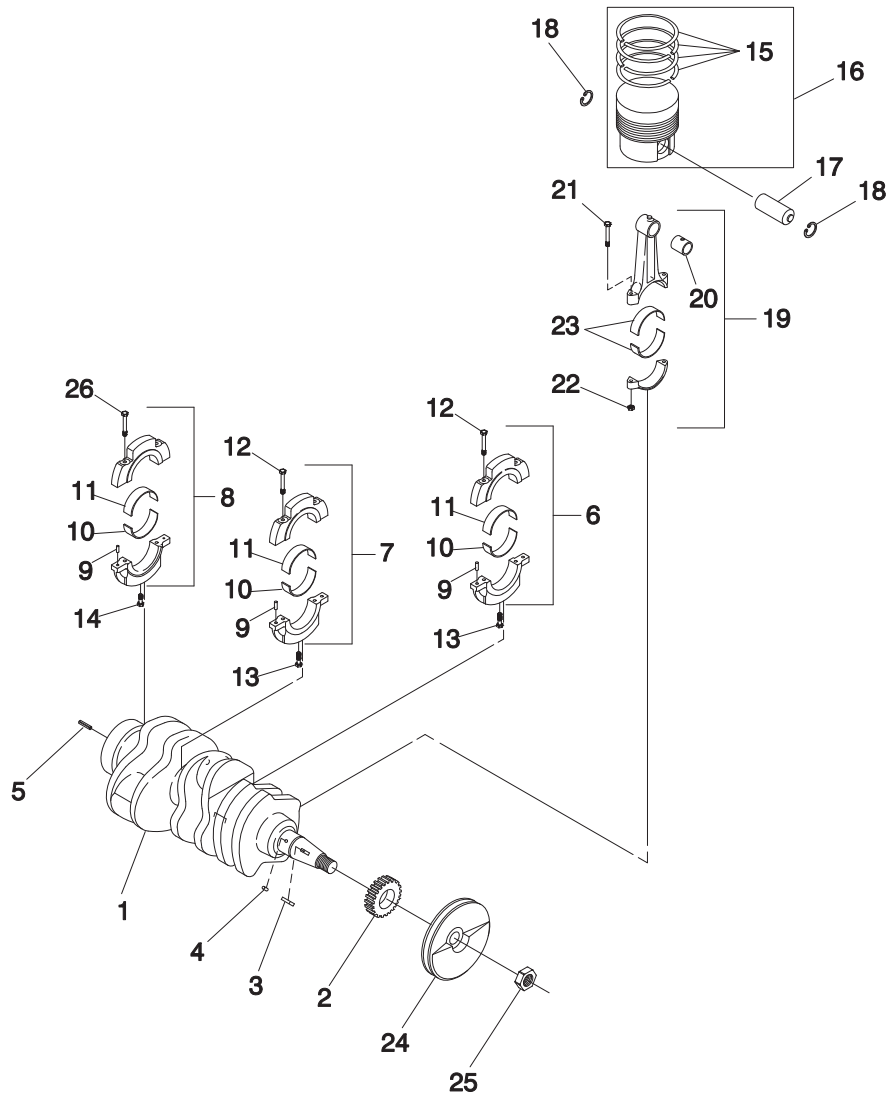

ITEM	PART NO.	QTY.	DESCRIPTION	ITEM	PART NO.	QTY.	DESCRIPTION
1	0G23210113	1	COMPLETE CRANKSHAFT	12	0709390198	4	BOLT
2	0709390194	1	CRANKSHAFT GEAR	13	0G23210124	2	BOLT
3	0709390195	1	KEY	14	0G23210125	2	BOLT
4	0709390196	1	DOWEL PIN	15	0G23210126	3	STANDARD PISTON RING KIT
5	0709390226	1	SPRING PIN	16	0G23210127	3	STANDARD PISTON KIT WITH RINGS
6	0G23210114	1	BEARING HOLDER ASSEMBLY	17	0709390217	3	PISTON PIN
7	0G23210115	1	BEARING HOLDER ASSEMBLY	18	0709390218	6	SNAP RING
8	0G23210116	1	BEARING HOLDER ASSEMBLY	19	0G23210128	3	CONNECTING ROD ASSEMBLY
9	0709390199	6	DOWEL PIN	20	0709390220	3	BUSHING
10	0G23210117	3	STANDARD METAL BEARING	21	0709390221	6	CONNECTING ROD BOLT
	0G23210118	3	0.25 STANDARD METAL BEARING	22	0709390222	6	NUT, CONNECTING ROD BOLT
	0G23210119	3	0.50 STANDARD METAL BEARING	23	0G23210129	6	STANDARD METAL BEARINGS
11	0G23210120	3	STANDARD UPPER METAL BEARING		0G23210130	6	0.25 STANDARD METAL BEARINGS
	0G23210121	3	0.25 STANDARD UPPER METAL BEARING		0G23210131	6	0.50 STANDARD METAL BEARINGS
	0G23210122	3	0.50 STANDARD UPPER METAL BEARING	24	0709390230	1	PULLEY
				25	0709390231	1	NUT
				26	0G23210123	2	BOLT

Section 6 – Exploded Views and Parts Lists

Recreational Vehicle Generator  
1.0 Liter Diesel Timing and Governor – Drawing No. 0G7506-A

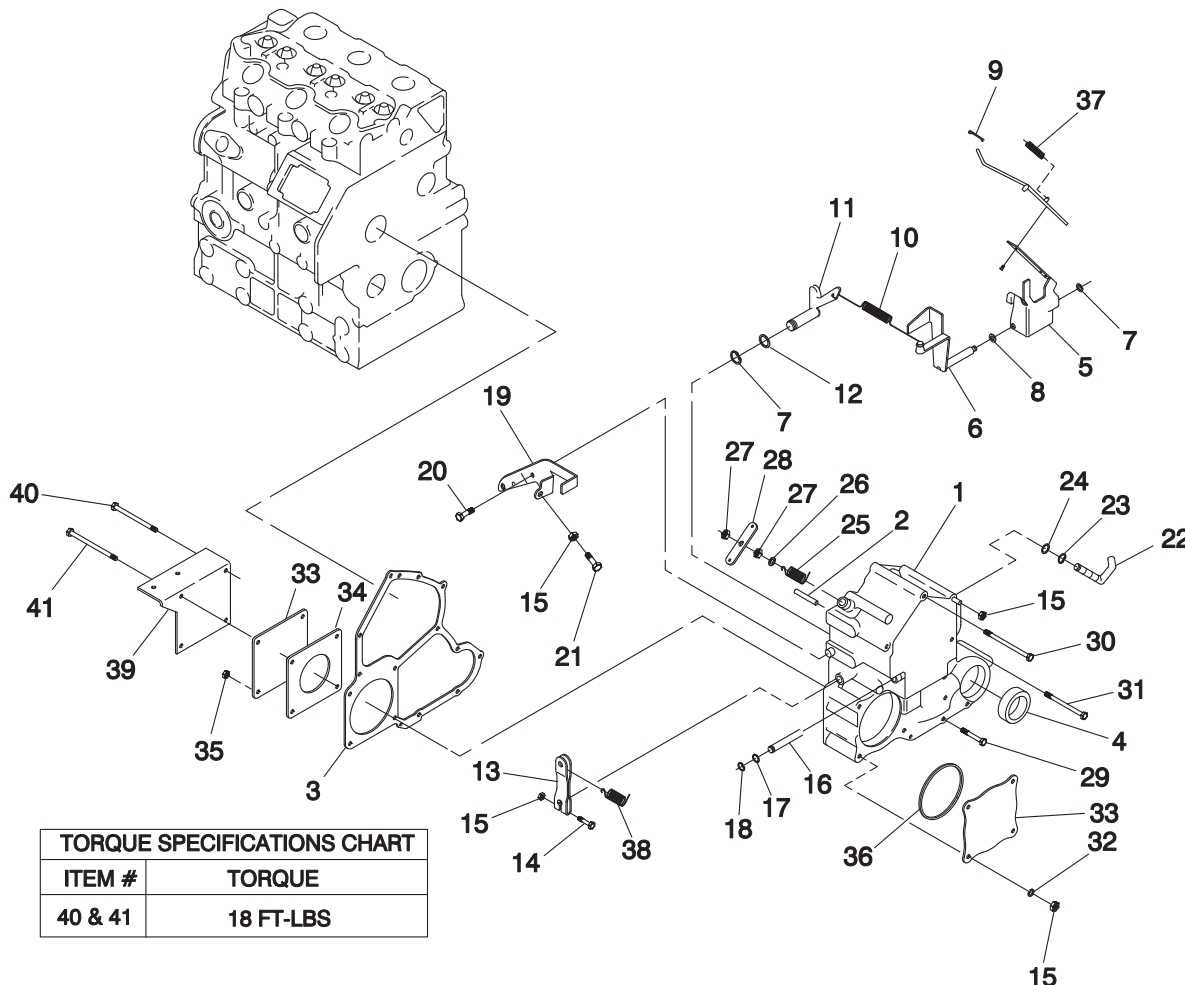
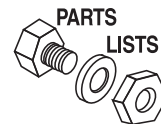

ITEM	PART NO.	QTY.	DESCRIPTION	ITEM	PART NO.	QTY.	DESCRIPTION
1	0F28730186	1	HOUSING, TIMING GEAR	22	0709390304	1	ARM
2	0709390286	1	SPRING PIN	23	0709390305	1	SNAP RING
3	0F28730187	1	GASKET	24	0F28730194	1	O-RING
4	0709390288	1	OIL SEAL	25	0709390307	1	SPRING
5	0G23210146	1	GOVERNOR LEVER ASSEMBLY	26	0709390308	1	WASHER
6	0709390290	1	TENSION LEVER	27	0G23210149	2	NUT
7	0709390291	2	SNAP RING	28	0709390310	1	STOP LEVER
8	0709390136	1	WASHER	29	0F28730195	5	BOLT
9	0709390292	1	COTTER PIN	30	0F28730180	3	BOLT
10	0G23210147	1	SPRING	31	0F28730150	2	BOLT
11	0709390294	1	ARM	32	022129	4	WASHER LOCK M8-5/16
12	0F28730190	1	O-RING	33	0709390314	2	COVER
13	0709390296	1	GOVERNOR LEVER	34	0G23210151	1	GASKET
14	0709390297	1	BOLT	35	045771	4	NUT
15	0F28730173	3	NUT	36	0709390660	1	O-RING
16	0F28730191	1	SHAFT	37	0709390313	1	SPRING
17	0F28730192	2	O-RING	38	0F28730199	1	SPRING
18	0709390301	1	SNAP RING	39	0C48880ST03	1	BRACKET FUEL FILTER BLACK
19	0709390302	1	BRACKET	40	051730	3	SCREW HHC M8-1.25 X 60 G8.8
20	0F28730218	2	BOLT	41	052265	1	SCREW HHC M8-1.25 X 65 G8.8
21	071944	1	BOLT				



## Section 6 – Exploded Views and Parts Lists

### Recreational Vehicle Generator

#### 1.0 Liter Diesel Injector Pump – Drawing No. 0G7507-A

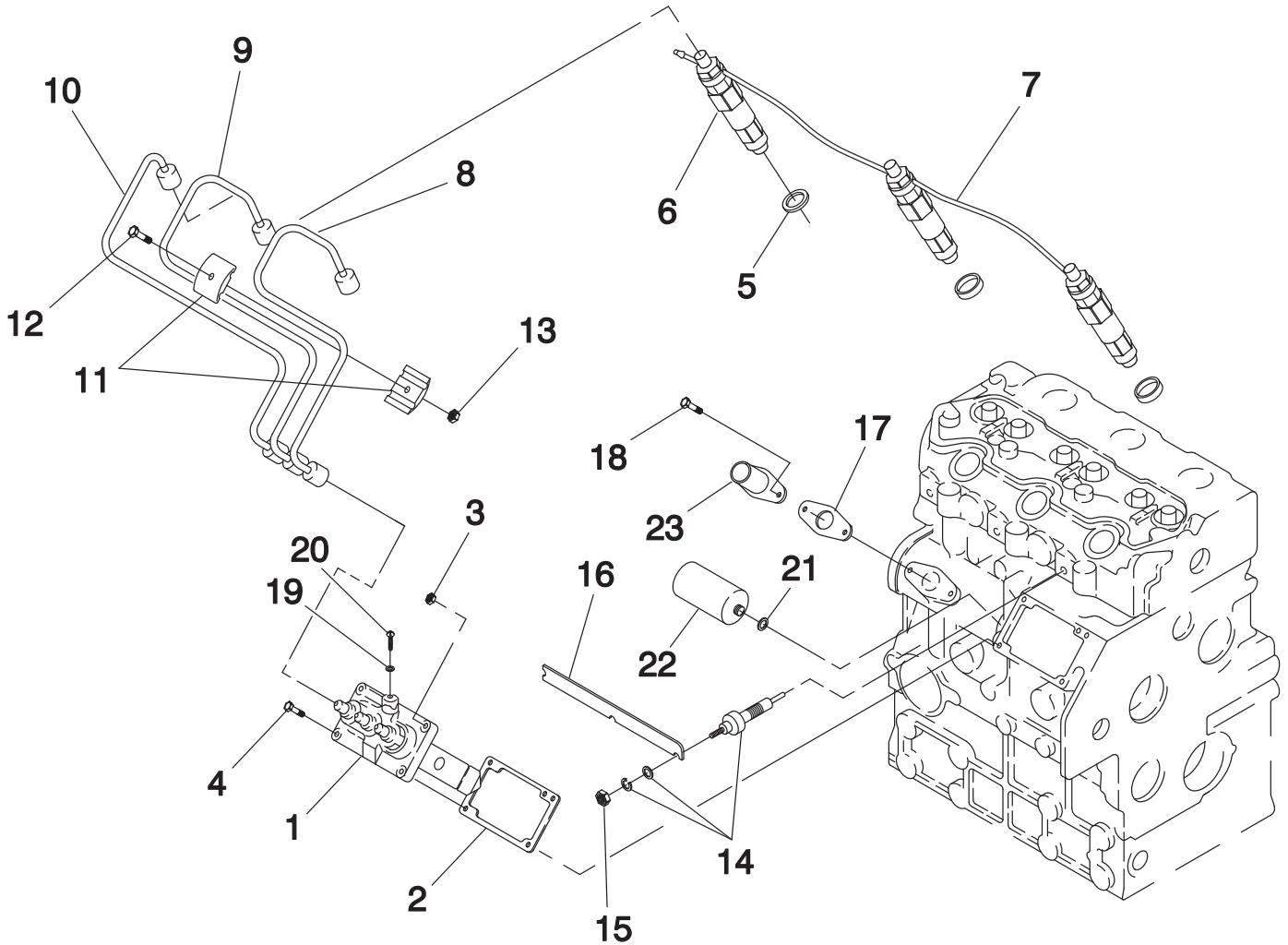

ITEM	PART NO.	QTY.	DESCRIPTION	ITEM	PART NO.	QTY.	DESCRIPTION
1	0G23210133	1	INJECTION PUMP ASSEMBLY	13	0F28730173	2	NUT
2	0F28730201	1	ADJUSTING SHIM SET	14	0F28730209	3	GLOW PLUG
3	0F28730173	2	NUT	15	0F28730210	3	NUT
4	0F28730202	2	BOLT	16	0G23210140	1	CONNECTOR
5	0F28730203	3	GASKET	17	0F28730214	1	GASKET
6	0G23210134	3	INJECTOR ASSEMBLY	18	0709390264	2	BOLT
7	0F28730205	1	COMPLETE RETURN PIPE	19	0709390343	1	SEAL WASHER
8	0G23210135	1	COMPLETE INJECTION PIPE	20	0F28730212	1	SCREW
9	0G23210136	1	COMPLETE INJECTION PIPE	21	0F28730176	1	SEAL WASHER FOR THERMO SWITCH
10	0G23210137	1	COMPLETE INJECTION PIPE	22	0F28730213	1	SOLENOID
11	0G23210138	4	COMPLETE CLAMP	23	0C4736	1	COVER
12	0G23210139	2	BOLT				

Section 6 – Exploded Views and Parts Lists

Recreational Vehicle Generator  
1.0 Liter Diesel Fuel Supply – Drawing No. 0G7508-A

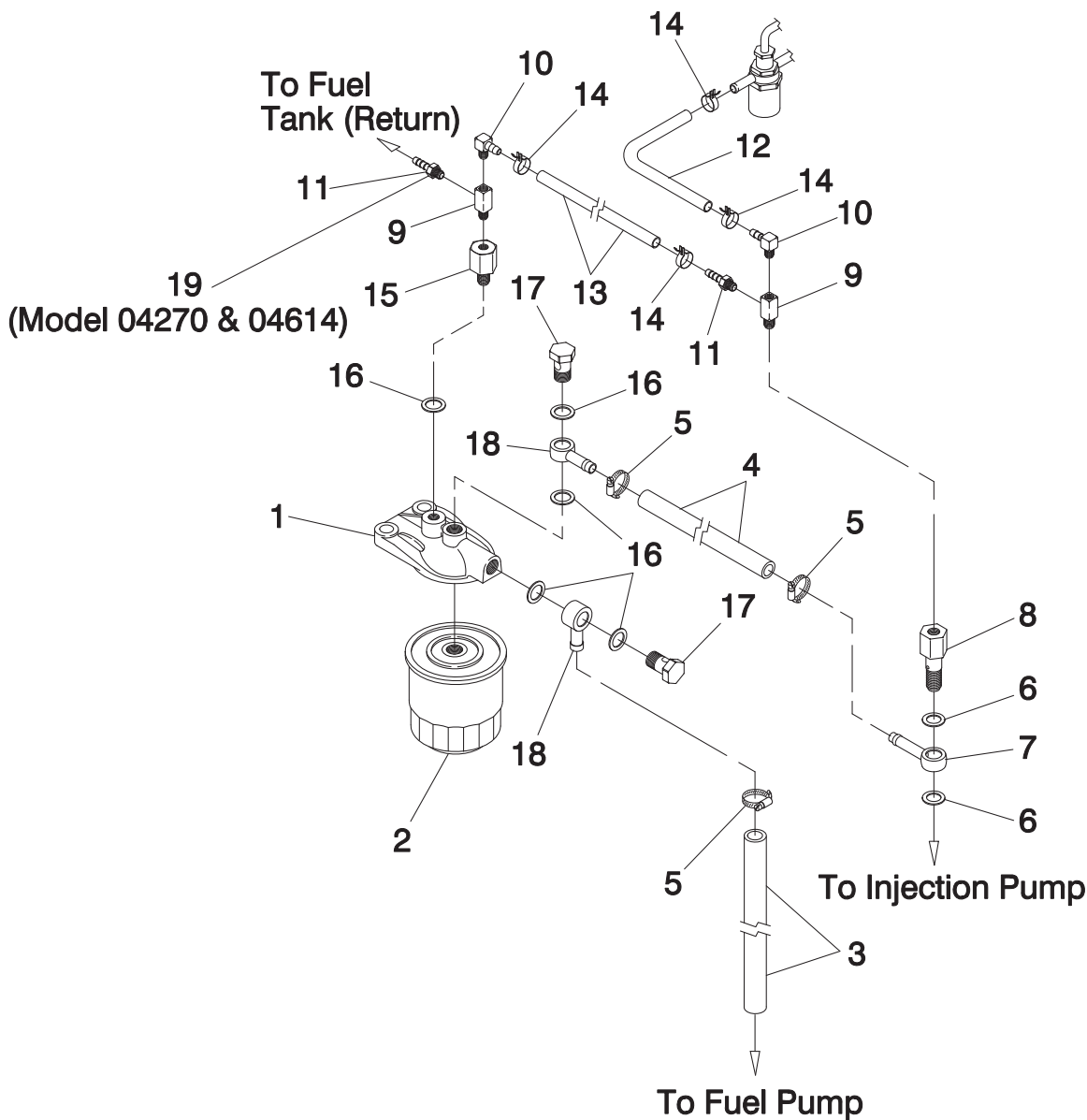
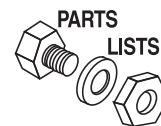

ITEM	PART NO.	QTY.	DESCRIPTION	ITEM	PART NO.	QTY.	DESCRIPTION
1	0F28730215	1	FUEL FILTER SUPPORT ASSEMBLY	12	068736	275MM	HOSE, 3/16" SAE 30R2
2	0G23210155	1	FUEL FILTER	13	068736	240MM	HOSE, 3/16" SAE 30R2
3	0C8008	AR	HOSE, 5/16" SAE 30R7	14	074823	4	HOSE CLAMP
4	0C8008	250MM	HOSE, 5/16" SAE 30R7	15	074819	1	FUEL BLEED FITTING
5	040173	3	HOSE CLAMP	16	0709390651	5	FUEL BLEED GASKET
6	0709390378	5	GASKET	17	0709390662	2	HOLLOW BOLT
7	0709390379	1	BANJO FITTING	18	0F28730216	2	BANJO FITTING
8	074808	1	FUEL BLEED FITTING	19	028414A	1	1/8" NPT x 1/4" BARBED STRAIGHT FITTING (MODEL 04270 & 04614)
9	052233	2	1/8" NPT TEE (BRASS) FITTING				
10	039450	2	1/8" NPT x 3/16" 90 DEG. BARBED FITTING				
11	030096	1	1/8" NPT x 3/16" BARBED STRAIGHT FITTING				
							AR - AS REQUIRED



## **FEDERAL AND CALIFORNIA EMISSIONS CONTROL WARRANTY STATEMENT**

(for non-road Diesel engines rated under 19 kW)

### **YOUR WARRANTY RIGHTS AND OBLIGATIONS**

The U.S. Environmental Protection Agency (EPA), the California Air Resources Board (CARB), Generac Power Systems, Inc. (GENERAC), and the engine manufacturer for this equipment, Ishikawajima Shibaura Machinery Co., Ltd. (ISM), are pleased to explain the federal and California emission control system warranty on your engine.

In California, new 2000 and later small non-road engines must be designed, built, and equipped to meet the state's stringent anti-smog standards. In other states, new 2000 and later non-road diesel engines rated under 19 kW must be designed, built, and equipped to conform to applicable EPA regulations.

ISM must warrant the emission control system on your engine for that period of time listed below, provided there has been no abuse, neglect, or improper maintenance of your small non-road diesel engine.

Your California and EPA emission control system may include parts, such as, the fuel injection system and other emission-related assemblies.

Where a warrantable condition exists, GENERAC will repair your engine at no cost to you, including diagnosis, parts, and labor, on behalf of ISM. Although ISM is ultimately responsible for this warranty, GENERAC has agreed to carry out ISM's warranty repair responsibilities, and GENERAC should be your primary contact for emission-related warranty service.

### **MANUFACTURER'S WARRANTY COVERAGE**

For 2000 and later small non-road diesel engines, first sold in California, and for 2000 and later non-road diesel engines rated under 19 kW, first sold in all other states, the applicable warranty period is two (2) years or 1,500 hours, whichever comes first.

If any emission-related part on your engine is defective, the part will be repaired or replaced by a Generac Authorized Warranty Service Facility on behalf of ISM.

### **PARTS COVERED**

This emission control system warranty applies to the following engine emission control parts.

- Fuel Injection Pump
- Fuel Injectors
- Intake Manifold
- Exhaust Manifold
- Air Cleaner Element
- Miscellaneous Hoses, Bolts and Connectors

### **OWNER'S WARRANTY RESPONSIBILITIES**

As the engine owner, you are responsible for the performance of the required maintenance listed in your *Owner's Manual*. GENERAC and ISM recommend that you retain the original purchase documentation and all receipts covering maintenance on your engine, but GENERAC and ISM cannot deny warranty solely for the lack of receipts or for your failure to ensure the performance of all scheduled maintenance.

As the engine owner, you should be aware, however, that GENERAC and ISM may deny you warranty coverage if your engine or a part has failed due to abuse, neglect, improper maintenance, or unapproved modifications.

**You are responsible for contacting a Generac Authorized Warranty Service Facility as soon as a problem occurs.** The warranty repairs should be completed in a reasonable amount of time, not to exceed 30 days.

Warranty Service can be arranged by contacting either your selling dealer or a Generac Authorized Warranty Service Facility. To locate the Generac Authorized Warranty Service Facility nearest you, call our toll-free number:

**1-800-333-1322**

**If you have any questions regarding your warranty rights and responsibilities, you should contact GENERAC at the following address:**

**ATTENTION WARRANTY DEPARTMENT  
GENERAC POWER SYSTEMS, INC.  
757 N. NEWCOME STREET  
WHITEWATER, WI 53190**



## OBLIGATIONS AND RIGHTS OF THE MANUFACTURER AND OWNER

The new model year, class of diesel engine, and emission application determination for your engine are identified on the emission control information label affixed to the right-hand side of your engine's timing gear case. The warranty period begins on the date the new equipment is sold to the first retail purchaser.

Any emission control system parts scheduled for regular inspection that are proven defective during normal use will be repaired or replaced during the warranty period. Any warranted part that is scheduled for replacement, and that fails prior to replacement, will be repaired or replaced under warranty, and the repaired or replaced part will be covered under warranty for the remainder of the period prior to the first scheduled replacement. The warranty repairs and service will be performed by any Generac Authorized Warranty Service Facility, with no charge for parts or labor (including diagnosis).

As the engine owner, you are responsible to perform all the required maintenance listed in your *Owner's Manual*. GENERAC will not deny an emission warranty claim solely because you have no record of maintenance; however, a claim may be denied if your failure to perform maintenance resulted in the failure of a warranted part. Receipts covering regular maintenance should be retained in the event of questions, and these receipts should be passed on to each subsequent owner of the engine.

It is recommended that replacement parts used for maintenance or repairs be GENERAC authorized and approved parts, to maintain the quality originally designed into your emission-certified engine. However, any replacement part may be used in the performance of any warranty maintenance or repairs and must be provided without charge to the owner. Such use will not reduce the warranty obligations of GENERAC. Add-on or modified parts may not be used for maintenance or warranty repairs. Such use will be grounds for disallowing a warranty claim, and GENERAC will not be liable to warrant failures of warranted parts caused by the use of an add-on or modified part.

## LIMITATIONS

This warranty shall not cover any of the following:

- (a) Systems and parts that were not first installed on the new equipment or engine as original equipment by GENERAC.
- (b) Conditions resulting from tampering, misuse, abuse, improper adjustment, engine alteration, use of add-on or modified parts, use of replacement parts that are not the same in performance and durability as GENERAC-approved replacement parts, accident, failure to use the recommended fuel or oil, use of unapproved fuel or oil additives, or failure to perform required maintenance.
- (c) Replacement parts used for required or scheduled maintenance.
- (d) Consequential damages, such as, loss of time, inconvenience, or loss of use of this engine or equipment.
- (e) Damages or repair costs caused by the owner's unreasonable delay in making the engine available for inspection and repair.
- (f) Diagnosis or inspection fees that do not result in eligible warranty service being performed.
- (g) Equipment with an altered or disconnected hourmeter, where the hours cannot be determined.
- (h) Equipment normally operated outside the United States.
- (i) Accident-caused damage, acts of nature, or other events beyond GENERAC'S control.
- (j) Warranty repairs undertaken or attempted by the owner or any other person who is not affiliated with a Generac Authorized Warranty Service Facility.

## OBTAINING WARRANTY SERVICE

To obtain service under this warranty, promptly contact your nearest Generac Authorized Service Dealer or a Generac Authorized Warranty Service Facility. If available, provide the GENERAC representative with the original purchase receipt (showing the initial date of purchase) and all available maintenance records.



**Section 7 – Warranty**  
**Recreational Vehicle Generator**

**GENERAC POWER SYSTEMS' THREE-YEAR LIMITED WARRANTY  
FOR GUARDIAN RECREATIONAL VEHICLE GENERATORS**

**NOTE: ALL UNITS MUST BE INSTALLED BY GENERAC POWER SYSTEMS AUTHORIZED SERVICE FACILITIES.** For a period of 3 (three) years of operation from the date of original sale, Generac Power Systems, Inc. (Generac) will, at its option, repair or replace any part which, upon examination, inspection and testing by Generac or a Generac Authorized Warranty Service Facility, is found to be defective under normal use and service, in accordance with the warranty schedule set forth below. Any equipment that the purchaser/owner claims to be defective must be returned to and examined by the nearest Generac Authorized Warranty Service Facility. All transportation costs under the warranty, including return to the factory, are to be borne and prepaid by the purchaser/owner. This warranty applies only to Generac generators sold and rated for "Recreational Vehicle" (RV) applications, as Generac has defined Recreational Vehicle generator applications. The factory recommends exercising the unit one half-hour every month.

**WARRANTY SCHEDULE – COMMERCIAL APPLICATIONS**

**YEAR ONE** – 100% (one hundred percent) coverage on part(s), labor, removal and reinstallation listed:

- **Engine** – All components
- **Alternator** – All components

**WARRANTY SCHEDULE – CONSUMER/PERSONAL APPLICATIONS**

**YEARS ONE AND TWO** – 100% (one hundred percent) coverage on part(s), labor, removal and reinstallation listed:

- **Engine** – All components
- **Alternator** – All components

**YEAR THREE** – 100% (one hundred percent) only on selected part(s) and labor listed [Any labor and part(s) not listed, and removal and reinstallation are the owner's responsibility]:

- Rotor, Stator, Computer Control Board (part numbers 0A6060 and 0A3369) and inverter, (if applicable with regard to the generator) Cylinder Block, Cylinder Head, Crankshaft, Piston(s), Valve, Valve Lifter(s), Intake and Exhaust Manifolds

Generac RV generators manufactured prior to December 31, 1997, **DO NOT** have a transferable warranty. Generac RV generators manufactured after January 1, 1998, have a transferable warranty to the second owner **ONLY** for the remainder of the three-year limited warranty. Proof-of-purchase is required and must be presented to a Generac Authorized Warranty Service Facility prior to the performance of any warranty service.

All warranty expense allowances **are** subject to the conditions defined in Guardian's Warranty Policies and Procedures Guide.

**THIS WARRANTY SHALL NOT APPLY TO THE FOLLOWING:**

- Generac Guardian generators that utilize non-Generac replacement parts.
- Costs of normal maintenance, adjustments, installation and start-up.
- Repairs or diagnostics performed by individuals other than Guardian/Generac authorized dealers not authorized in writing by Generac Power Systems.
- Failures caused by any contaminated fuels, oils, coolants or lack of proper fluid amounts.
- Failures due, but not limited, to normal wear and tear, accident, misuse, abuse, negligence or improper installation. As with all mechanical devices, the Generac engines need periodic part(s) service and replacement to perform well. This warranty will not cover repair when normal use has exhausted the life of a part(s) or engine.
- Failures caused by any external cause or act of God, such as collision, theft, vandalism, riot or wars, nuclear holocaust, fire, freezing, lightning, earthquake, windstorm, hail, volcanic eruption, water or flood, tornado or hurricane.
- Damage related to rodent and/or insect infestation.
- Products that are modified or altered in a manner not authorized by Generac in writing.
- Any incidental, consequential or indirect damages caused by defects in materials or workmanship, or any delay in repair or replacement of the defective part(s).
- Failure due to misapplication.
- Telephone, cellular phone, facsimile, internet access or other communication expenses.
- Living or travel expenses of person(s) performing service, except as specifically included within the terms of a specific unit warranty period.
- Expenses related to "customer instruction" or troubleshooting where no manufacturing defect is found.
- Rental equipment used while warranty repairs are being performed.
- Overnight freight costs for replacement part(s).
- Overtime labor.
- Starting batteries, fuses, light bulbs and engine fluids.

THIS WARRANTY IS IN PLACE OF ALL OTHER WARRANTIES, EXPRESSED OR IMPLIED. SPECIFICALLY, GENERAC MAKES NO OTHER WARRANTIES AS TO THE MERCHANTABILITY OR FITNESS FOR A PARTICULAR PURPOSE. Some states do not allow limitations on how long an implied warranty lasts, so the above limitation may not apply to you.

GENERAC'S ONLY LIABILITY SHALL BE THE REPAIR OR REPLACEMENT OF PART(S) AS STATED ABOVE. IN NO EVENT SHALL GENERAC BE LIABLE FOR ANY INCIDENTAL OR CONSEQUENTIAL DAMAGES, EVEN IF SUCH DAMAGES ARE A DIRECT RESULT OF GENERAC'S NEGLIGENCE. Some states do not allow the exclusion or limitation of incidental or consequential damages, so the above limitation may not apply to you.

This warranty gives you specific legal rights. You also have other rights from state to state.

**GENERAC® POWER SYSTEMS, INC.**  
P.O. BOX 297 • WHITEWATER, WI 53190

Revision 02.05