

## Mobile Generator – MMG330 Specifications

### ENGINE

- John Deere® PE6090HFG95 - turbocharged, diesel engine
  - Prime - 396 hp @ 1800 rpm
  - Standby - 440 hp @ 1800 rpm
  - 6 cylinder
  - 9.0 L displacement
  - Interim Tier IV emissions
- Steel, single wall fuel tank
  - 459 gal. capacity
  - 23 hr. run time – full load
  - Fuel tank built into skid of generator set
- Fuel consumption at prime:
  - 100% - 18.7 gph (70.8 Lph)
  - 75% - 14.1 gph (53.4 Lph)
  - 50% - 9.6 gph (36.3 Lph)
- Cooling system capable of operating at 120°F ambient
- Low coolant shutdown
- Radiator and oil drains plumbed to exterior
- Rubber vibration dampers isolate engine/generator from frame
- In-line engine block heater
- Disposable air filter - paper element
- Air filter restriction indicator mounted on control panel
- 60 Hz engine/generator
- Electronic isochronous governing
- Utilizes DOC/DPF exhaust filter
- Variable Geometry Turbocharger (VGT)

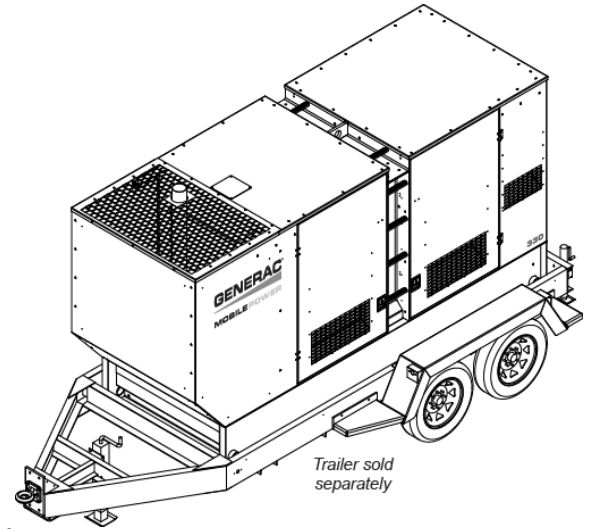

### GENERATOR

- Marathon Electric®
  - Brushless
  - 4 pole
  - Class H insulation
- Voltage regulation +/- 1% with Marathon SE350 Voltage Regulator

### SYSTEM OUTPUT

- Link / Reconnect Board:
  - Three phase – 120 / 208V Low Wye
  - Three phase – 277 / 480V High Wye
- 290 kW / 363 kVA – standby, three phase
- 263 kW / 329 kVA – prime, three phase

### SYSTEM CONTROLS

- Microprocessor-based controller
  - Backlit, 128x64 pixel resolution display
  - -40°F to 185°F operating temperature range
  - Thermostatically controlled LCD heater

- Six LED indicators w/ lamp test
  - ◆ Alarm / Fault (Red)
  - ◆ Ready / Manual (Red)
  - ◆ Running (Green)
  - ◆ Warning (Yellow)
  - ◆ Ready / Auto (Green)
  - ◆ Supplying Load (Green)
- Push buttons for easy operation
  - Manual or Auto Start
  - Engine Start or Stop
  - Alarm Cancel & Fault Reset
  - Scrolling Arrows for Diagnostic Information
    - ◆ System kW output display
    - ◆ Line output & frequency display
    - ◆ Engine diagnostic display
      - Oil pressure
      - Engine temperature
      - Fuel level
      - Battery
    - ◆ System hours
      - Running hours
      - kW hours
      - Time to service
  - Alarm list – warnings / shutdowns are date & time stamped
    - ◆ Fuel level: warning – 15%; shutdown – 5%
    - ◆ Overspeed protection: shutdown – 115%
    - ◆ Oil pressure: warning – 25 psi; shutdown – 20 psi
    - ◆ Coolant temperature: warning – 220°F; shutdown – 230°F
    - ◆ Battery voltage: over – 15VDC; under – 11VDC
    - ◆ Generator over voltage: warning – 110%; shutdown – 111%
    - ◆ Generator under voltage: warning – 87%; shutdown – 86%
    - ◆ Generator over frequency: warning – 105%; shutdown – 110%
    - ◆ Generator under frequency: warning – 95%; shutdown – 90%
    - ◆ Over current shutdown

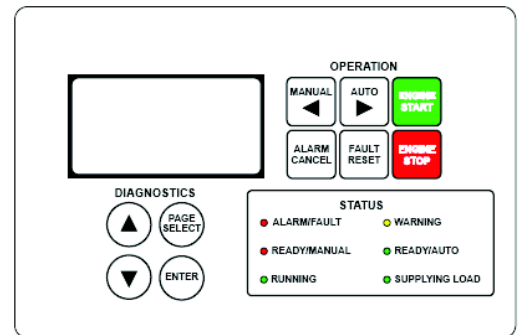

## ELECTRICAL CONTROLS

- Remote start / stop contacts located next to lug box
- Lockable control box door with diagnostics window
- Lockable lug box with safety switch
  - Trips main breaker when lug door is opened
  - Disables voltage regulator
- Cable entry guides to the lug box
  - Restricts access of foreign objects
- Output ground connection lug inside lug box
- 1200A main breaker with shunt trip
- Convenience receptacles with individual breakers (restricted use in high wye mode)
  - (2) 120V 20 Amp GFCI duplex outlets (Nema 5-20R type)
  - (3) 125 / 250V 50 Amp, 3 pole, 4 wire twistlock (Non-Nema 6369)
  - Buck Transformer kit – Provides 120V at GFCI outlets when in 277/480V
- Panel mounted rheostat for voltage adjustment - +/- 10%

- (2) 1000 CCA wet cell batteries
  - Battery disconnect switch
  - 2A trickle battery charger

## ENCLOSURE

- Generac Mobile Power decals
- Aluminum, sound attenuated enclosure
  - UV & fade resistant, high temperature cured, white polyester powder paint
  - Insulated and baffled
  - 68 dB(A) at 23 feet – prime power
- Fully lockable enclosure including doors and fuel fill
- Stainless steel hinges on doors
- Emergency stop switch located on outside of enclosure
- Central lifting point
- Multi-lingual operating/safety decals
- Document holder with operating manual including AC/DC wiring diagrams

## TRAILER

- DOT approved tail, side, brake, and directional lights
  - Recessed rear lights
- Transportation tie downs
- Safety chains with spring loaded safety hooks
- 3" lunette ring hitch
- (2) 8000 lb. axles with electric brakes
- 15000 lb. tongue jack with footplate
- ST215/75R17.5 tubeless tires – 16 ply

## WEIGHTS & DIMENSIONS

### Skid mounted

- Dry weight: 8039 lbs (3646 kg)
- Operating weight: 11499 lbs (5216 kg)
- 156 x 60 x 90 in  
(3.96 x 1.52 x 2.29 m)

### Trailer mounted

- Dry weight: 10912 lbs  
(4950 kg)
- Operating weight: 14372 lbs  
(6519 kg)
- 230 x 102 x 110 in  
(5.84 x 2.59 x 2.79 m)

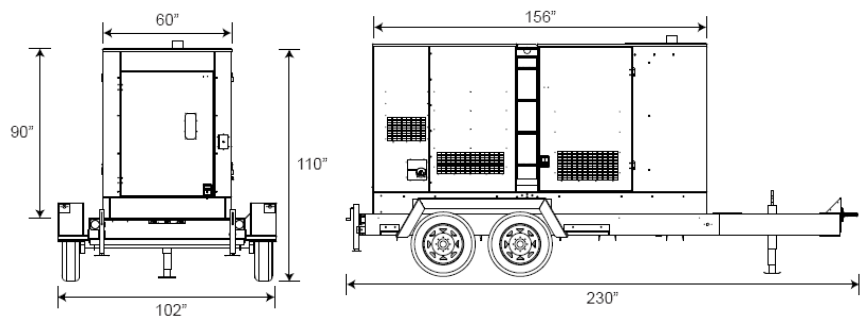

## WARRANTY

- Engine and generator covered under OEM warranty – consult factory for details.

## CERTIFICATIONS

- CSA certified

## MMG320 Options

### GENERATOR OPTIONS

- ◆ PMG Generator - critical grade power quality
- ◆ SUPERSTART™ Generator - motor starting applications
  - 294 kW / 367 kVA – standby, three phase
  - 263 kW / 329 kVA – prime, three phase

### VOLTAGE OUTPUT OPTIONS

- ◆ 4 position phase switch
  - Single phase – 120 / 240V Zig Zag
  - Three phase – 120 / 208V Low Wye
  - Three phase – 277 / 480V High Wye
  - Three phase – 120 / 240V Delta
- ◆ Dedicated voltage configurations
- ◆ Cam locks

### SYSTEM CONTROLS OPTIONS

- ◆ Auxiliary strobe/audible indication for soft & hard alarm conditions

### COOLANT OPTIONS

- ◆ 60/40 Coolant - cold weather applications

### ENCLOSURE OPTIONS

- ◆ Fire extinguisher
- ◆ Interior cabinet light
- ◆ Control panel light

### FUEL TANK OPTIONS

- ◆ 36 hr. single wall fuel tank
- ◆ 120% Containment
- ◆ Fuel transfer pump

### TRAILER OPTIONS

- ◆ 6 pin or 7 spade electrical connectors
- ◆ Spare tire/wheel kit

### HITCH OPTIONS

- ◆ Adjustable height - 3" lunette ring