

GENERAC[®]

POWER SYSTEMS, INC.

Owner's Manual

- SAFETY
- ASSEMBLY
- OPERATION
- TROUBLESHOOTING
- WARRANTY

AUTHORIZED DEALER SUPPORT:

www.generac.com
or
1-888-436-3722

GP Series Portable Generator

**2 YEAR
LIMITED
WARRANTY**

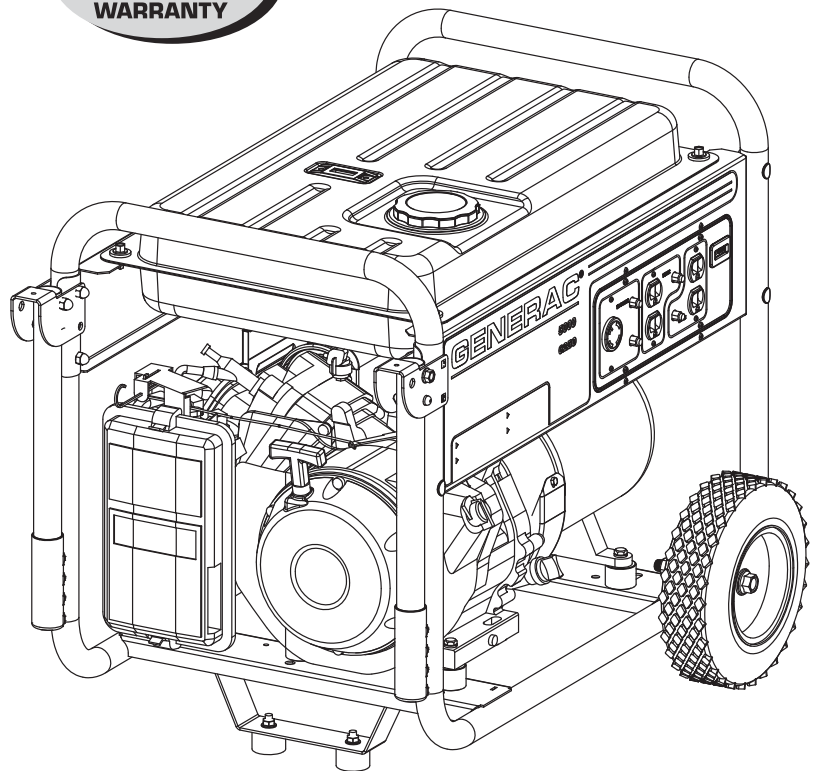

COMMERCIAL • INDUSTRIAL • RESIDENTIAL

MODELS: 005622-0, 005623-0

**TABLE
OF
CONTENTS**

**Table of Contents
Portable Generator System**

Introduction..... 1
Read this Manual Thoroughly 1
Safety Rules..... 2
 Standards Index..... 3

Section 1 – General Information 4
1.1 Unpacking..... 4
 1.1.1 Accessory Box 4
1.2 Assembly 4
 1.2.1 Assembling the Accessory Kit 4

Section 2 – Operation 4
2.1 Know the Generator 4
2.2 Hourmeter..... 5
2.3 Cord Sets and Connection Plugs 6
 2.3.1 120 VAC, 20 Amp, Duplex Receptacle..... 6
 2.3.2 120/240 VAC, 30 Amp, Receptacle..... 6
2.4 How to Use the Generator..... 6
 2.4.1 Grounding the Generator 6
 2.4.2 Connecting Electrical Loads 6
2.5 Don't Overload the Generator 7
2.6 Wattage Reference Guide 7
2.7 Before Starting the Generator 7
 2.7.1 Adding Engine Oil 7
 2.7.2 Adding Gasoline..... 8
2.8 To Start the Engine..... 8
2.9 Stopping the Engine 9
2.10 Low Oil Level Shutdown System 9
 2.10.1 Sensing Low Oil Level 9

Section 3 – Maintenance 9
3.1 Maintenance Schedule..... 9
3.2 Product Specifications 9
 3.2.1 Generator Specifications..... 9
 3.2.2 Engine Specifications..... 9
3.3 General Recommendations 10
 3.3.1 Generator Maintenance 10
 3.3.2 To Clean the Generator 10
 3.3.3 Engine Maintenance 10
 3.3.4 Checking Oil Level 10
 3.3.5 Changing the Oil..... 10
 3.3.6 Replacing the Spark Plug 10
3.4 Service Air Filter 10
3.5 Valve Clearance..... 11
3.6 General 11
3.7 Long Term Storage 11
3.8 Other Storage Tips 11

Section 4 – Troubleshooting..... 12
4.1 Troubleshooting Guide..... 12

Section 5 – Notes 13

Section 6 – Warranty Back Cover

INTRODUCTION

Thank you for purchasing this model of the GP Series portable generator by Generac Power Systems, Inc. This model is a compact, high performance, air-cooled, engine driven generator designed to supply electrical power to operate electrical loads on job sites, or remote locations where no utility power is available or in place of utility power due to a power outage.

READ THIS MANUAL THOROUGHLY

If any portion of this manual is not understood, contact the nearest Authorized Dealer for starting, operating and servicing procedures.

Throughout this publication, and on tags and decals affixed to the generator, DANGER, WARNING, CAUTION and NOTE blocks are used to alert personnel to special instructions about a particular operation that may be hazardous if performed incorrectly or carelessly. Observe them carefully. Their definitions are as follows:

— **DANGER** —

After this heading, read instructions that, if not strictly complied with, will result in serious personal injury, including death and/or property damage.

— **WARNING** —

After this heading, read instructions that, if not strictly complied with, may result in serious personal injury and/or property damage.

— **CAUTION** —

After this heading, read instructions that, if not strictly complied with, could result in damage to equipment and/or property.

NOTE:

After this heading, read explanatory statements that require special emphasis.

These safety warnings cannot eliminate the hazards that they indicate. Common sense and strict compliance with the special instructions while performing the service are essential to preventing accidents.

Four commonly used safety symbols accompany the **DANGER**, **WARNING** and **CAUTION** blocks. The type of information each indicates is as follows:

 **This symbol points out important safety information that, if not followed, could endanger personal safety and/or property of others.**

 **This symbol points out potential explosion hazard.**

 **This symbol points out potential fire hazard.**

 **This symbol points out potential electrical shock hazard.**

The operator is responsible for proper and safe use of the equipment. We strongly recommend that the operator read this manual and thoroughly understand all instructions before using the equipment.

We also strongly recommend instructing other users to properly start and operate the unit. This prepares them if they need to operate the equipment in an emergency.

— **DANGER** —

 **Using a generator indoors WILL KILL YOU IN MINUTES. Exhaust contains carbon monoxide, a poison gas you cannot see or smell.**

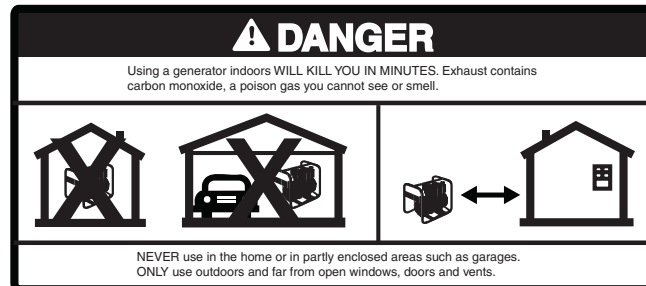

— **WARNING** —

 **Always disconnect the spark plug wire and place the wire where they cannot contact the spark plug to prevent accidental starting when setting up, transporting, adjusting or making repairs to the generator.**

- The generator produces dangerously high voltage that can cause extremely hazardous electrical shock. Avoid contact with bare wires, terminals, etc. Never permit any unqualified person to operate or service the generator.
- Never handle any kind of electrical cord or device while standing in water, while barefoot or while hands or feet are wet. Dangerous electrical shock will result.
- The National Electric Code requires the frame and external electrically conductive parts of the generator be properly connected to an approved earth ground. Local electrical codes may also require proper grounding of the generator. Consult with a local electrician for grounding requirements in the area.
- Do not use worn, bare, frayed or otherwise damaged electrical cord sets with the generator.
- Operate generator only on level surfaces and where it will not be exposed to excessive moisture, dirt, dust or corrosive vapors.
- Gasoline is highly **FLAMMABLE** and its vapors are **EXPLOSIVE**. Do not permit smoking, open flames, sparks or heat in the vicinity while handling gasoline. Avoid spilling gasoline on a hot engine. Comply with all laws regulating storage and handling of gasoline.

 **Never add fuel while unit is running.**

 **Do not overfill the fuel tank. Always allow room for fuel expansion. If tank is over-filled, fuel can overflow onto a hot engine and cause FIRE or an EXPLOSION.**

- Never store generator with fuel in tank where gasoline vapors might reach an open flame, spark or pilot light (as on a furnace, water heater or clothes dryer). **FIRE** or **EXPLOSION** may result.
- Generator exhaust gases contain **DEADLY** carbon monoxide gas. This dangerous gas, if breathed in sufficient concentrations, can cause unconsciousness or even death. Operate this equipment only in the open air where adequate ventilation is available.



⚠ SAVE THESE INSTRUCTIONS – The manufacturer suggests that these rules for safe operation be copied and posted near the unit's installation site. Safety should be stressed to all operators and potential operators of this equipment.

⚠ WARNING ⚠

- ⚠ Allow at least five (5) feet, or greater, of clearance on all sides of generator. Never operate the unit inside any room or enclosure.
- ⚠ NEVER operate the generator indoors, in an attached garage or near an open window.
- Never start or stop the unit with electrical loads connected to receptacles AND with connected devices turned ON. Start the engine and let it stabilize before connecting electrical loads. Disconnect all electrical loads before shutting down the generator.
- Do not insert objects through unit's cooling slots.
- **Never operate generator:** in rain; indoors or in any enclosed compartment; if connected electrical devices overheat; if electrical output is lost; if engine or generator sparks; if flames or smoke are observed while unit is running; if unit vibrates excessively.

Study these **SAFETY RULES** carefully before installing, operating or servicing this equipment. Become familiar with this manual and with the unit. The generator can operate safely, efficiently and reliably only if it is properly installed, operated and maintained. Many accidents are caused by failing to follow simple and fundamental rules or precautions.

⚠ DANGER ⚠

- ⚠ Despite the safe design of this generator, operating this equipment imprudently, neglecting its maintenance or being careless can cause possible injury or death. Permit only responsible and capable persons to operate or maintain this equipment.
- ⚠ Potentially lethal voltages are generated by these machines. Ensure all steps are taken to render the machine safe before attempting to work on the generator.
- ⚠ Parts of the generator are rotating and/or hot during operation. Exercise care near running generators. Do not touch hot surfaces such as the muffler. Severe burns can occur on contact. Allow generator to cool before touching.

⚠ GENERAL HAZARDS ⚠

- Never operate in an enclosed area or indoors.
- For safety reasons, the manufacturer recommends that the maintenance of this equipment is carried out by an Authorized Dealer.
- The engine exhaust fumes contain carbon monoxide, which can be DEADLY. This dangerous gas, if breathed in sufficient concentrations, can cause unconsciousness or even death. This exhaust system must be properly maintained. Do nothing that might render the exhaust system unsafe or in noncompliance with any local codes and/or standards.
- Keep hands, feet, clothing, etc., away from drive belts, fans, and other moving or hot parts. Never remove any fan guard while the unit is operating.
- Adequate, unobstructed flow of cooling and ventilating air is critical to correct generator operation. Do not alter the installation or permit even partial blockage of ventilation provisions, as this can seriously affect safe operation of the generator. The generator MUST be operated outdoors.
- When working on this equipment, remain alert at all times. Never work on the equipment when physically or mentally fatigued.
- Inspect the generator regularly, and contact the nearest Authorized Dealer for parts needing repair or replacement.
- Before performing any maintenance on the generator, disconnect its battery cables (if equipped) to prevent accidental start up. Disconnect the cable from the battery post indicated by a NEGATIVE, NEG or (–) first. Reconnect that cable last.
- Never use the generator or any of its parts as a step. Stepping on the unit can stress and break parts, and may result in dangerous operating conditions from leaking exhaust gases, fuel leakage, oil leakage, etc.
- Do NOT operate generator in the rain.

⚠ WARNING: ⚠
The engine exhaust from this product contains chemicals known to the state of California to cause cancer, birth defects or other reproductive harm.

⚠ WARNING: ⚠
This product contains or emits chemicals known to the state of California to cause cancer, birth defects or other reproductive harm.

The manufacturer cannot anticipate every possible circumstance that might involve a hazard. The warnings in this manual, and on tags and decals affixed to the unit are, therefore, not all inclusive. If using a procedure, work method or operating technique that the manufacturer does not specifically recommend, ensure that it is safe for others. Also make sure the procedure, work method or operating technique utilized does not render the generator unsafe.



 **ELECTRICAL HAZARDS** 

- All generators covered by this manual produce dangerous electrical voltages and can cause fatal electrical shock. Utility power delivers extremely high and dangerous voltages as does the generator when it is in operation. Avoid contact with bare wires, terminals, connections, etc., while the unit is running. Ensure all appropriate covers, guards and barriers are in place before operating the generator. If work must be done around an operating unit, stand on an insulated, dry surface to reduce shock hazard.
- Do not handle any kind of electrical device while standing in water, while barefoot, or while hands or feet are wet. **DANGEROUS ELECTRICAL SHOCK MAY RESULT.**
- The National Electrical Code (NEC) requires the frame and external electrically conductive parts of the generator to be connected to an approved earth ground. Local electrical codes also may require proper grounding of the generator electrical system.
- In case of accident caused by electric shock, immediately shut down the source of electrical power. If this is not possible, attempt to free the victim from the live conductor. **AVOID DIRECT CONTACT WITH THE VICTIM.** Use a non-conducting implement, such as a rope or board, to free the victim from the live conductor. If the victim is unconscious, apply first aid and get immediate medical help.
- Never wear jewelry when working on this equipment. Jewelry can conduct electricity resulting in electric shock, or may get caught in moving components causing injury.

 **FIRE HAZARDS** 

- For fire safety, the generator must be operated and maintained properly. Operation must always comply with applicable codes, standards, laws and regulations. Adhere strictly to local, state and national electrical and building codes. Comply with regulations the Occupational Safety and Health Administration (OSHA) has established. Also, ensure that the generator is operated in accordance with the manufacturer's instructions and recommendations. Do not alter the construction of the generator or change controls which might create an unsafe operating condition.
- Keep a fire extinguisher near the generator at all times. Extinguishers rated "ABC" by the National Fire Protection Association are appropriate for use on the portable generator electric system. Keep the extinguisher properly charged and be familiar with its use. If there are any questions pertaining to fire extinguishers, consult the local fire department.
- Avoid spilling gasoline on a hot engine. NEVER add fuel while the unit is running. DO NOT overfill the fuel tank. Always allow room for fuel expansion.

 **EXPLOSION HAZARDS** 

- Do not smoke around the generator. Wipe up any fuel or oil spills immediately. Ensure that no combustible materials are left on or near the generator, as FIRE or EXPLOSION may result. Keep the area surrounding the generator clean and free from debris.
- Gasoline vapors are extremely FLAMMABLE and EXPLOSIVE.

STANDARDS INDEX

In the absence of pertinent standards, codes, regulations and laws, the published information listed below may be used as a guideline for operation of this equipment. Always reference the latest revision available for the standards listed.

1. NFPA No. 70, NFPA HANDBOOK OF NATIONAL ELECTRIC CODE.
2. Article X, NATIONAL BUILDING CODE, available from the American Insurance Association, 85 John Street, New York, N.Y. 10038.
3. AGRICULTURAL WIRING HANDBOOK, available from the Food and Energy Council, 909 University Avenue, Columbia, MO 65201.
4. ASAE EP-3634, INSTALLATION AND MAINTENANCE OF FARM STANDBY ELECTRICAL SYSTEMS, available from the American Society of Agricultural Engineers, 2950 Niles Road, St. Joseph, MI 49085.
5. NFPA No. 30, FLAMMABLE AND COMBUSTIBLE LIQUIDS CODE.

1.1 UNPACKING

- Remove all packaging material.
- Remove separate accessory box.
- Remove the generator from carton.

1.1.1 ACCESSORY BOX

Check all contents. If any parts are missing or damaged locate an authorized dealer at 1-888-436-3722.

Contents Include:

- 1 - Owner's Manual
- 1 - Quart Oil SAE 30
- 2 - Never-Flat Wheels
- 1 - Foot Support
- 1 - Hardware Bag (containing the following):
 - 2 - Rubber Feet
 - 2 - 5/16" Bolts
 - 2 - 5/16" Flat Washers
 - 4 - 5/16" Carriage Bolts
 - 2 - 1/2" Axle Bolts
 - 2 - 1/2" Flat Washers
 - 1 - Left Handle Assembly
 - 1 - Right Handle Assembly
 - 1 - Frame Foot

1.2 ASSEMBLY

The generator requires some assembly prior to using it. If problems arise when assembling the generator, please call the Generator Helpline at 1-888-436-3722.

1.2.1 ASSEMBLING THE ACCESSORY KIT

The wheels are designed into the unit to greatly improve the portability of the generator.

NOTE:

The wheels are not intended for over-the-road use.

1. Refer to Figure 1 and install Wheels as follows:
 - Slide the 1/2" Axle Bolt through the Wheel and Wheel bracket on frame.
 - Install 1/2" Locking Flange Nuts onto 1/2" Flange Bolt.
2. Refer to Figure 1 and install Frame Foot and Rubber Feet as shown.
 - Slide Rubber Foot stud through Frame Foot; Install 5/16" Locking Flange Nuts Slide 5/16" Bolt through 5/16" Flat Washer and then through holes in Frame Rail.
 - Slide Frame Foot onto 5/16" Bolts; Install 5/16" Locking Flange Nuts.
3. Refer to Figure 2 and install Handles as shown.
 - Remove top Curved Head Bolts and Cap Nuts (Cap Nuts will be re-used).
 - Slide Handle Assembly over Frame Tube, aligning 2 holes.
 - Slide 5/16" Carriage Bolts through; Install 5/16" Cap Nuts.

Figure 1 – Wheel Assembly

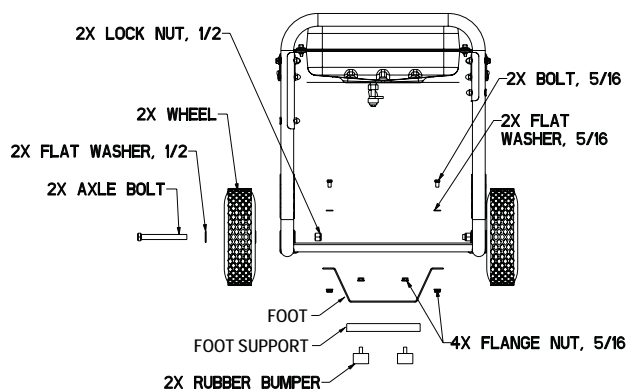
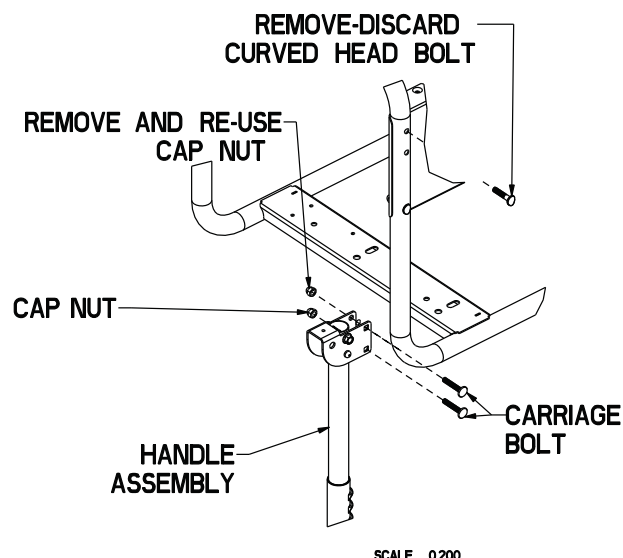

Figure 2 – Install Handle Kit



2.1 KNOW THE GENERATOR

Read the Owner's Manual and Safety Rules before operating this generator.

Compare the generator to Figures 3 through 5 to become familiarized with the locations of various controls and adjustments. Save this manual for future reference.

1. **120 Volt AC, 20 Amp, Duplex Receptacle** – Supplies electrical power for the operation of 120 Volt AC, 20 Amp, single-phase, 60 Hz electrical lighting, appliance, tool and motor loads.
2. **120/240 Volt AC, 30 Amp Locking Receptacle** – Supplies electrical power for the operation of 120 and/or 240 Volt AC, 30 Amp, single-phase, 60 Hz, electrical lighting, appliance, tool and motor loads.
3. **Circuit Breakers (AC)** – Each receptacle is provided with a push-to-reset circuit breaker to protect the generator against electrical overload.

Figure 3 - Control Panel

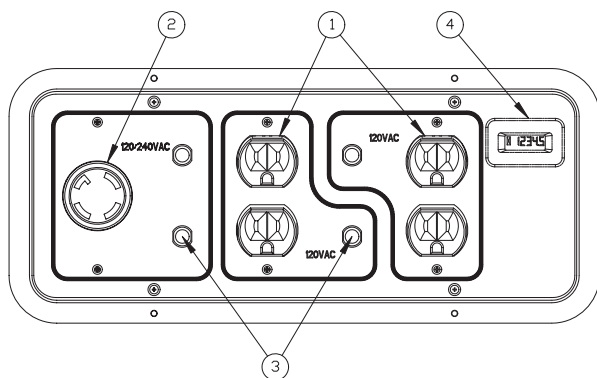

4. **Hourmeter** – Tracks hours of operation.
5. **Air Filter** – Filters intake air as it is drawn into the engine.
6. **Choke Knob** – Used when starting a cold engine.
7. **Fuel Tank** – Tank holds 6.6 U.S. gallons of fuel.
8. **Grounding Lug** – Ground the generator to an approved earth ground here. See "Grounding the Generator" for details.
9. **Run/Stop Switch** – Controls the operation of the generator.
10. **Muffler** – Quiets the engine.
11. **Handles** – Pivot and retract for storage. Press the spring-loaded button to move handles.
12. **Gas Cap** – Fuel fill location.
13. **Fuel Gauge** – Shows fuel level in tank.
14. **Oil Fill** – Add oil here.
15. **Recoil Starter** – Use to start engine manually.
16. **Fuel Shut Off** – Valve between fuel tank and carburetor.
17. **Oil Drain** – Use to drain engine oil.

Figure 4 - Generator Controls

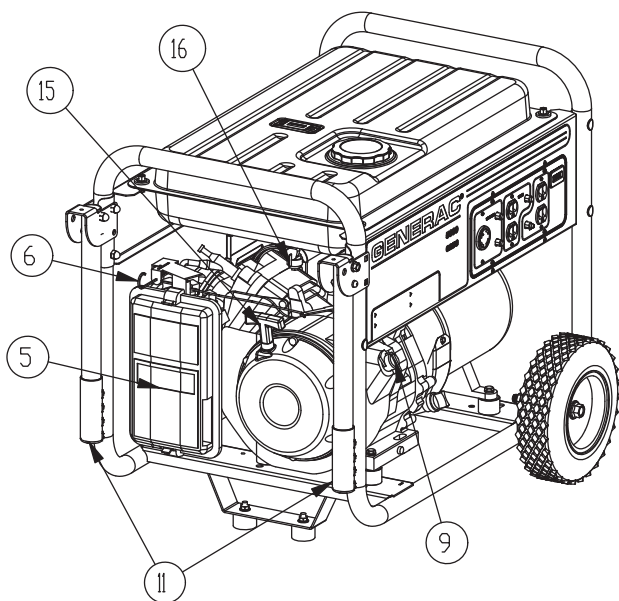
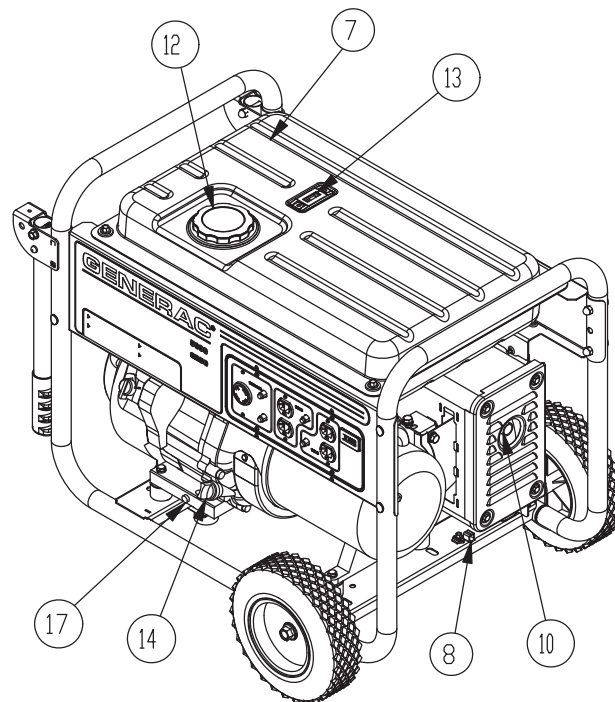

Figure 5 - Generator Controls



2.2 HOURMETER

The Hourmeter tracks hours of operation for scheduled maintenance:

There will be a "CHG OIL" message every 100 hours. The message will flash one hour before and one hour after each 100 hour interval, again providing a two hour window to perform service.

This message will actually begin flashing at 99 hours and disable itself at 101 hours providing a two hour window to perform the service.

Every 200 hours the "SVC" icon on the lower left hand corner of the display will flash. The message will flash one hour before and one hour after each 200 hour interval providing a two hour window to perform service.

When the hour meter is in the Flash Alert mode, the maintenance message will always alternate with elapsed time in hours and tenths. The hours will flash four times, then alternate with the maintenance message four times until the meter resets itself.

- 30 hours - CHG OIL — Break-in Interval (First 30 hrs only)
- 100 hours - CHG OIL — Oil Change Interval (Every 100 hrs)
- 200 hours - SVC — Air Filter Interval (Every 200 hrs)

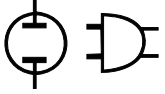

2.3 CORD SETS AND CONNECTION PLUGS

2.3.1 120 VAC, 20 AMP, DUPLEX RECEPTACLE

This is a 120 Volt outlet protected against overload by a 20 Amp push-to-reset circuit breaker (Figure 6). Use each socket to power 120 Volt AC, single phase, 60 Hz electrical loads requiring up to a combined 2400 watts (2.4 kW) or 20 Amps of current. Use only high quality, well-insulated, 3-wire grounded cord sets rated for 125 Volts at 20 Amps (or greater).

Keep extension cords as short as possible, preferably less than 15 feet long, to prevent voltage drop and possible overheating of wires.

Figure 6 - 120 Volt AC, 20 Amp, Duplex Receptacle

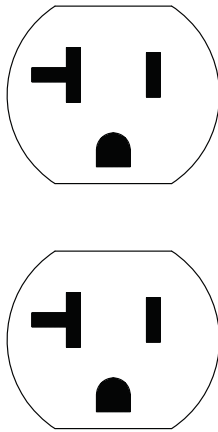

2.3.2 120/240 VAC, 30 AMP RECEPTACLE

Use a NEMA L14-30 plug with this receptacle (rotate to lock/unlock). Connect a suitable 4-wire grounded cord set to the plug and to the desired load. The cord set should be rated for 250 Volts AC at 30 Amps (or greater) (Figure 7).

Figure 7 - 120/240 VAC, 30 Amp Receptacle

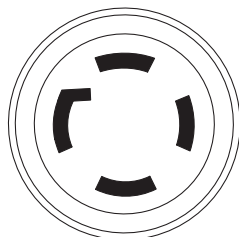

120V/240V
30A

Use this receptacle to operate 120 Volt AC, 60 Hz, single phase loads requiring up to 3600 watts (3.6 kW) of power at 30 Amps or 240 Volt AC, 60 Hz, single phase loads requiring up to 7200 watts (7.2 kW) of power at 30 Amps. The outlet is protected by two 30 Amp push-to-reset circuit breakers.

2.4 HOW TO USE THE GENERATOR

If there are any problems operating the generator, please call the generator helpline at 1-888-436-3722.

2.4.1 GROUNDING THE GENERATOR

The National Electrical Code requires that the frame and external electrically conductive parts of this generator be properly connected to an approved earth ground (Figure 8). Local electrical codes may also require proper grounding of the unit. For that purpose, connecting a No. 10 AWG (American Wire Gauge) stranded copper wire to the grounding lug and to an earth-driven copper or brass grounding rod (electrode) provides adequate protection against electrical shock. However, local codes may vary widely. Consult with a local electrician for grounding requirements in the area.

Figure 8 - Grounding the Generator

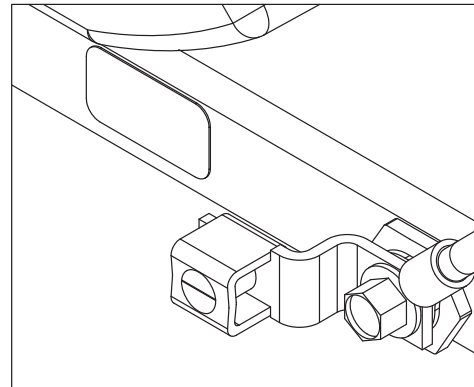

Proper grounding of the generator will help prevent electrical shock in the event of a ground fault condition in the generator or in connected electrical devices. Proper grounding also helps dissipate static electricity, which often builds up in ungrounded devices.

2.4.2 CONNECTING ELECTRICAL LOADS

DO NOT connect 240 Volt loads to 120 Volt receptacles. **DO NOT** connect 3-phase loads to the generator. **DO NOT** connect 50 Hz loads to the generator.

- Let engine stabilize and warm up for a few minutes after starting.
- Plug in and turn on the desired 120 or 240 Volt AC, single phase, 60 Hz electrical loads.
- Add up the rated watts (or amps) of all loads to be connected at one time. This total should not be greater than (a) the rated wattage/ampere capacity of the generator or (b) circuit breaker rating of the receptacle supplying the power. See "Don't Overload the Generator".

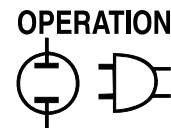

2.5 DON'T OVERLOAD THE GENERATOR

Overloading a generator in excess of its rated wattage capacity can result in damage to the generator and to connected electrical devices. Observe the following to prevent overloading the unit:

- Add up the total wattage of all electrical devices to be connected at one time. This total should NOT be greater than the generator's wattage capacity.
 - The rated wattage of lights can be taken from light bulbs. The rated wattage of tools, appliances and motors can usually be found on a data label or decal affixed to the device.
 - If the appliance, tool or motor does not give wattage, multiply volts times ampere rating to determine watts (volts x amps = watts).
 - Some electric motors, such as induction types, require about three times more watts of power for starting than for running. This surge of power lasts only a few seconds when starting such motors. Make sure to allow for high starting wattage when selecting electrical devices to connect to the generator:
 1. Figure the watts needed to start the largest motor.
 2. Add to that figure the running watts of all other connected loads.
- The Wattage Reference Guide is provided to assist in determining how many items the generator can operate at one time.

NOTE:

All figures are approximate. See data label on appliance for wattage requirements.

| | |
|--------------------------------------|---------------|
| Hand Drill | 250 to 1100 |
| Hedge Trimmer | 450 |
| Impact Wrench | 500 |
| Iron | 1200 |
| *Jet Pump | 800 |
| Lawn Mower | 1200 |
| Light Bulb | 100 |
| Microwave Oven | 700 to 1000 |
| *Milk Cooler | 1100 |
| Oil Burner on Furnace | 300 |
| Oil Fired Space Heater (140,000 Btu) | 400 |
| Oil Fired Space Heater (85,000 Btu) | 225 |
| Oil Fired Space Heater (30,000 Btu) | 150 |
| *Paint Sprayer, Airless (1/3 HP) | 600 |
| Paint Sprayer, Airless (handheld) | 150 |
| Radio | .50 to 200 |
| *Refrigerator | 700 |
| Slow Cooker | 200 |
| *Submersible Pump (1-1/2 HP) | 2800 |
| *Submersible Pump (1 HP) | 2000 |
| *Submersible Pump (1/2 HP) | 1500 |
| *Sump Pump | .800 to 1050 |
| *Table Saw (10") | 1750 to 2000 |
| Television | .200 to 500 |
| Toaster | .1000 to 1650 |
| Weed Trimmer | 500 |

* Allow 3 times the listed watts for starting these devices.

2.6 WATTAGE REFERENCE GUIDE

| Device | Running Watts |
|-------------------------------|---------------|
| *Air Conditioner (12,000 Btu) | 1700 |
| *Air Conditioner (24,000 Btu) | 3800 |
| *Air Conditioner (40,000 Btu) | 6000 |
| Battery Charger (20 Amp) | 500 |
| Belt Sander (3") | 1000 |
| Chain Saw | 1200 |
| Circular Saw (6-1/2") | .800 to 1000 |
| *Clothes Dryer (Electric) | 5750 |
| *Clothes Dryer (Gas) | 700 |
| *Clothes Washer | 1150 |
| Coffee Maker | 1750 |
| *Compressor (1 HP) | 2000 |
| *Compressor (3/4 HP) | 1800 |
| *Compressor (1/2 HP) | 1400 |
| Curling Iron | 700 |
| *Dehumidifier | 650 |
| Disc Sander (9") | 1200 |
| Edge Trimmer | 500 |
| Electric Blanket | 400 |
| Electric Nail Gun | 1200 |
| Electric Range (per element) | 1500 |
| Electric Skillet | 1250 |
| *Freezer | .700 |
| *Furnace Fan (3/5 HP) | 875 |
| *Garage Door Opener | .500 to 750 |
| Hair Dryer | 1200 |

2.7 BEFORE STARTING THE GENERATOR

Prior to operating the generator, engine oil and gasoline will need to be added, as follows:

2.7.1 ADDING ENGINE OIL

All oil should meet minimum American Petroleum Institute (API) Service Class SJ, SL or better. Use no special additives. Select the oil's viscosity grade according to the expected operating temperature (also see chart).

- Above 40° F, use SAE 30
- Below 40° F and down to 10° F, use 10W-30
- Below 10° F, use synthetic 5W-30

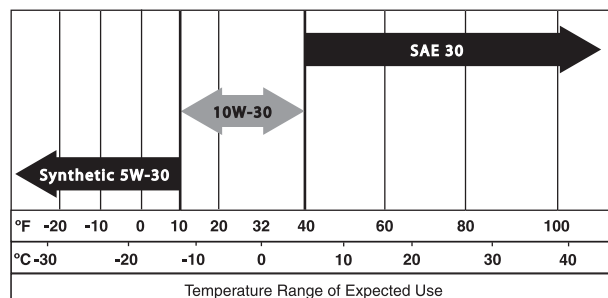

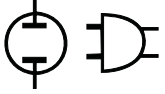

—▲ CAUTION ▲—

▲ **Any attempt to crank or start the engine before it has been properly serviced with the recommended oil may result in an engine failure.**

- Place generator on a level surface.
- Clean area around oil fill and remove oil fill cap and dipstick.
- Wipe dipstick clean.
- Slowly fill engine with oil through the oil fill opening until it reaches the full mark. Stop filling occasionally to check oil level. **Be careful not to over fill.**
- Install oil fill cap and finger tighten securely.
- Check engine oil level before starting each time thereafter.

2.7.2 ADDING GASOLINE

—▲ DANGER ▲—

▲ **Never fill fuel tank indoors. Avoid spilling gasoline on hot engine. Never fill fuel tank when engine is running or hot. DO NOT light a cigarette or smoke when filling the fuel tank. Gasoline is highly flammable and its vapors are explosive.**

—▲ CAUTION ▲—

▲ **Do not overfill the fuel tank. Always leave room for fuel expansion. If the fuel tank is over-filled, fuel can over flow onto hot engine and cause an explosion.**

- Use regular UNLEADED gasoline with the generator engine. Do not use premium gasoline. Do not mix oil with gasoline.
- Clean area around fuel fill cap, remove cap.
- Slowly add unleaded regular gasoline to fuel tank. Fill to bottom of screen filter. **Be careful not to overfill** (Figure 9).
- Install fuel cap and wipe up any spilled gasoline.

Figure 9 - Fuel Tank

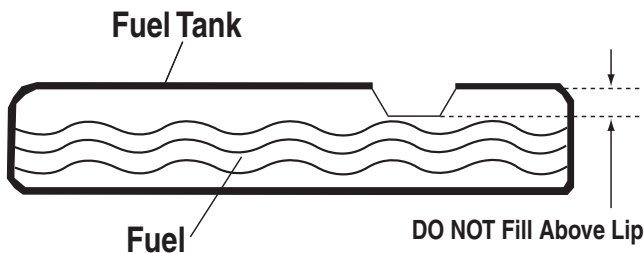

IMPORTANT: It is important to prevent gum deposits from forming in fuel system parts such as the carburetor, fuel hose or tank during storage. Alcohol-blended fuels (called gasohol, ethanol or methanol) can attract moisture, which leads to separation and formation of acids during storage. Acidic gas can damage the fuel system of an engine while in storage. To avoid engine problems, the fuel system should be emptied before storage of 30 days or longer. See the "Storage" section. Never use engine or carburetor cleaner products in the fuel tank as permanent damage may occur.

2.8 TO START THE ENGINE

—▲ WARNING ▲—

▲ **Never start or stop engine with electrical devices plugged into the receptacles AND devices turned on.**

- Unplug all electrical loads from the unit's receptacles before starting the engine.
- Make sure the unit is in a level position.
- OPEN the Fuel Shut-off Valve (Figure 10).

Figure 10 - Fuel Shut-off Valve

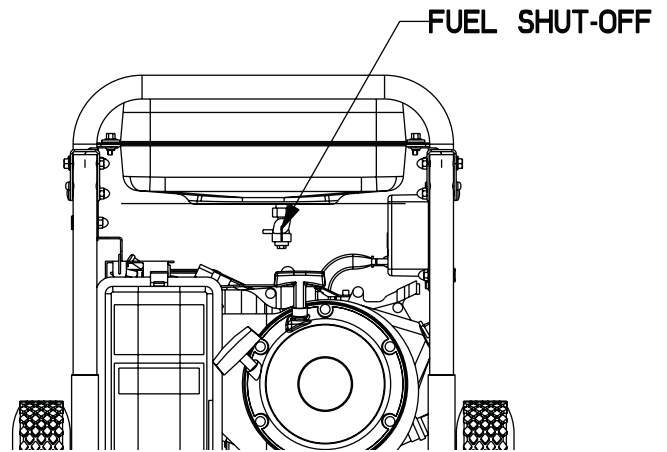

- Turn engine RUN/STOP switch to ON position (Figure 11).
- Pull engine CHOKE knob outward to FULL CHOKE position (Figure 11).
- To start engine, firmly grasp the recoil handle and pull slowly until increased resistance is felt. Pull rapidly up and away.
- When engine starts, move choke knob to 1/2-CHOKE position until engine runs smoothly and then fully into RUN position. If engine falters, move choke back out to 1/2-CHOKE position until engine runs smoothly and then to RUN position.

NOTE:

If engine fires, but does not continue to run, move choke lever to FULL CHOKE and repeat starting instructions.

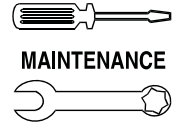
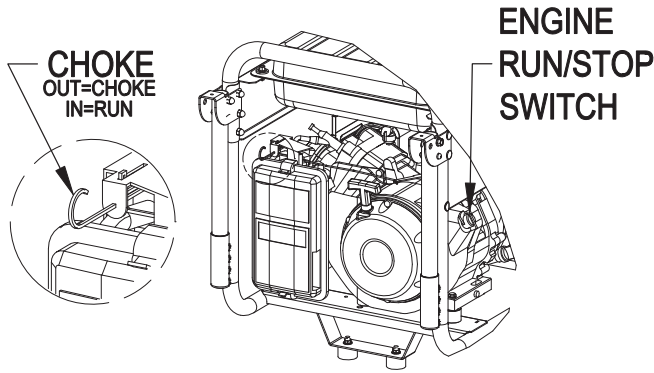

Figure 11 - Choke Position



IMPORTANT: Do not overload the generator. Also, do not overload individual panel receptacles. These outlets are protected against overload with push-to-reset-type circuit breakers. If amperage rating of any circuit breaker is exceeded, that breaker opens and electrical output to that receptacle is lost. Read “Don’t Overload the Generator” carefully.

2.9 STOPPING THE ENGINE

- Shut off all loads, then unplug the electrical loads from generator panel receptacles. Never start or stop the engine with electrical devices plugged in and turned on.
- Let engine run at no-load for several minutes to stabilize the internal temperatures of engine and generator.
- Move Run/Stop switch to OFF position.
- Close fuel valve.

2.10 LOW OIL LEVEL SHUTDOWN SYSTEM

The engine is equipped with a low oil level sensor that shuts down the engine automatically when the oil level drops below a specified level. If the engine shuts down by itself and the fuel tank has enough gasoline, check engine oil level.

2.10.1 SENSING LOW OIL LEVEL

If the system senses a low oil level during operation, the engine shuts down. The engine will not run until the oil has been refilled to the proper level.

3.1 MAINTENANCE SCHEDULE

Follow the calendar intervals. More frequent service is required when operating in adverse conditions noted below.

| | |
|-----------------------|------------------------------------|
| Check Oil Level | At Each Use |
| Change Oil ‡ | *Every 100 hours or Every Season |
| Check Valve Clearance | ***Every Season |
| Service Air Filter | ** Every 200 hours or Every Season |
| Replace Spark Plug | Every Season |

- ‡ Change oil after first 30 hours of operation then every season.
- * Change oil and oil filter every month when operating under heavy load or in high temperatures.
- ** Clean more often under dirty or dusty operating conditions. Replace air filter parts if they cannot be adequately cleaned.
- *** Check valve clearance and adjust if necessary after first 50 hours of operation and every 100 hours thereafter.

3.2 PRODUCT SPECIFICATIONS

3.2.1 GENERATOR SPECIFICATIONS

| | |
|-----------------------------------|-------------------|
| Rated Power | 5.0/6.5 kW** |
| Surge Power | 6.25/8.0 kW |
| Rated AC Voltage | 120/240 |
| Rated Max AC Load | |
| Current @ 240V (5.0/6.5 kW) | 25 Amps/30 Amps** |
| Current @ 120V | 20 Amps** |
| Rated Frequency | 60 Hz @ 3600 RPM |
| Phase | Single Phase |

** Maximum wattage and current are subject to, and limited by, such factors as fuel Btu content, ambient temperature, altitude, engine condition, etc.. Maximum power decreases about 3.5% for each 1,000 feet above sea level; and will also decrease about 1% for each 6° C (10° F) above 16° C (60° F) ambient temperature.

3.2.2 ENGINE SPECIFICATIONS

| | |
|--|--|
| Displacement..... | 389 cc |
| Spark Plug Type | NHSP F7RTC or Champion RN9YC |
| Spark Plug Gap (5.0/6.5 kW) | 0.028-0.031 inch or (0.70-0.80 mm) |
| Gasoline Capacity | 6.6 U.S. gallons |
| Oil Type..... | See Chart in "Before Starting the Generator" Section |
| Oil Capacity | 1.1 L (1.16 Qts.) |
| Run Time at 50% Load (5.0/6.5 kW) | 10/9 Hours |
| Fuel Consumption-1/2 Load (5.0/6.5 kW) | 0.66/0.73 gallons per hour |
| Class II Emission Certified* | |

* The engine manufacturer must warrant the emission control system for a period of two years. This warranty coverage is in addition to the warranty provided by Generac, and may cover the engine even if Generac’s warranty does not.

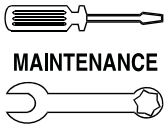

3.3 GENERAL RECOMMENDATIONS

The warranty of the generator does not cover items that have been subjected to operator abuse or negligence. To receive full value from the warranty, the operator must maintain the generator as instructed in this manual.

Some adjustments will need to be made periodically to properly maintain the generator.

All adjustments in the Maintenance section of this manual should be made at least once each season. Follow the requirements in the "Maintenance Schedule".

NOTE:

Once a year replace the spark plug and replace the air filter. A new spark plug and clean air filter assure proper fuel-air mixture and help the engine run better and last longer.

3.3.1 GENERATOR MAINTENANCE

Generator maintenance consists of keeping the unit clean and dry. Operate and store the unit in a clean dry environment where it will not be exposed to excessive dust, dirt, moisture or any corrosive vapors. Cooling air slots in the generator must not become clogged with snow, leaves, or any other foreign material.

Check the cleanliness of the generator frequently and clean when dust, dirt, oil, moisture or other foreign substances are visible on its exterior surface.



Never insert any object or tool through the air cooling slots, even if the engine is not running.

NOTE:

DO NOT use a garden hose to clean generator. Water can enter the engine fuel system and cause problems. In addition, if water enters the generator through cooling air slots, some water will be retained in voids and crevices of the rotor and stator winding insulation. Water and dirt buildup on the generator internal windings will eventually decrease the insulation resistance of these windings.

3.3.2 TO CLEAN THE GENERATOR

- Use a damp cloth to wipe exterior surfaces clean.
- A soft, bristle brush may be used to loosen caked on dirt, oil, etc.
- A vacuum cleaner may be used to pick up loose dirt and debris.
- Low pressure air (not to exceed 25 psi) may be used to blow away dirt. Inspect cooling air slots and openings on the generator. These openings must be kept clean and unobstructed.

3.3.3 ENGINE MAINTENANCE



When working on the generator, always disconnect negative cable from battery. Also disconnect spark plug wires from spark plug and keep wire away from spark plug.

3.3.4 CHECKING OIL LEVEL

See the "Before Starting the Generator" section for information on checking the oil level. The oil level should be checked before each use, or at least every eight hours of operation. Keep the oil level maintained.

3.3.5 CHANGING THE OIL

Change the oil after every 100 hours. If running this unit under dirty or dusty conditions, or in extremely hot weather, change the oil more often.

NOTE:

Whenever possible, run engine for approximately five (5) minutes to get the engine oil hot. This will aid in draining the oil.

Use the following instructions to change the oil while the engine is still warm:

- Clean area around oil drain plug.
- Remove oil drain plug from engine and oil fill plug to drain oil completely into a suitable container.
- When oil has completely drained, install oil drain plug and tighten securely.
- Fill oil sump with recommended oil. (See "Before Starting the Generator" for oil recommendations).
- Wipe up any spilled oil.

3.3.6 REPLACING THE SPARK PLUG

Use Champion RN9YC spark plug or equivalent. **Replace the plug once each year.** This will help the engine start easier and run better.

1. Stop the engine and pull the spark plug wire off of the spark plug.
2. Clean the area around the spark plug and remove it from the cylinder head.
3. Set the spark plug's gap to 0.70-0.80 mm (0.028-0.031 in.). Install the correctly gapped spark plug into the cylinder head (Figure 12).

Figure 12 - Spark Plug Gap

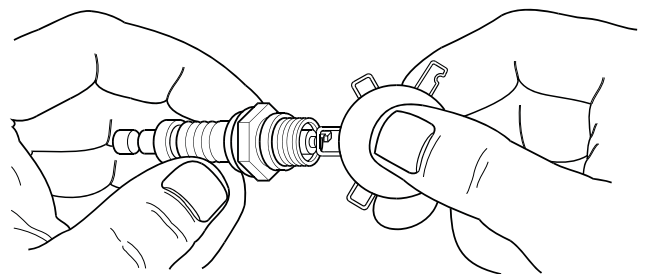

3.4 SERVICE AIR FILTER

The engine will not run properly and may be damaged if using a dirty air filter. Clean the air filter every 200 hours or once a year (Figure 13). Clean or replace more often if operating under dusty conditions.

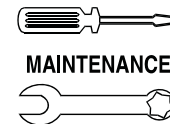

- Remove air filter cover.
- Wash in soapy water. Squeeze filter dry in clean cloth (DO NOT TWIST).
- Clean air filter cover before re-installing it.

NOTE:

To order a new air filter, please contact the nearest authorized service center at 1-888-436-3722.

Figure 13 - Air Filter

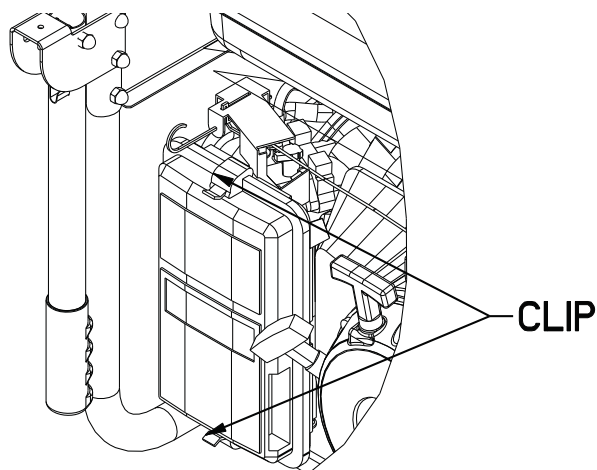

3.5 VALVE CLEARANCE

- Intake — $0.15 \pm 0.02\text{mm}$ (cold), ($0.006'' \pm 0.0008''$ inches)
- Exhaust — $0.0020 \pm 0.02\text{mm}$ (cold) ($0.008'' \pm 0.0008''$ inches)

After the first 50 hours of operation, check the valve clearance in the engine and adjust if necessary.

Important: If feeling uncomfortable about doing this procedure or the proper tools are not available, please take the generator to the nearest service center to have the valve clearance adjusted. This is a very important step to insure longest life for the engine.

3.6 GENERAL

The generator should be started at least once every seven days and be allowed to run at least 30 minutes. If this cannot be done and the unit must be stored for more than 30 days, use the following information as a guide to prepare it for storage.



NEVER store engine with fuel in tank indoors or in enclosed, poorly ventilated areas where fumes may reach an open flame, spark or pilot light as on a furnace, water heater, clothes dryer or other gas appliance.

3.7 LONG TERM STORAGE

It is important to prevent gum deposits from forming in essential fuel system parts such as the carburetor, fuel hose or tank during storage. Also, experience indicates that alcohol-blended fuels (called gasohol, ethanol or methanol) can attract moisture, which leads to separation and formation of acids during storage. Acidic gas can damage the fuel system of an engine while in storage.

To avoid engine problems, the fuel system should be emptied before storage of 30 days or longer, as follows:

- Remove all gasoline from the fuel tank.



Drain fuel into approved container outdoors, away from open flame. Be sure engine is cool. Do not smoke.

- Start and run engine until engine stops from lack of fuel.
- While engine is still warm, drain oil from crankcase. Refill with recommended grade.
- Remove spark plugs and pour about 1/2 ounce (15 ml) of engine oil into the cylinders. Cover spark plug hole with rag. Pull the recoil starter a couple times to lubricate the piston rings and cylinder bore..



Avoid spray from spark plug holes when cranking engine.

- Install and tighten spark plugs. Do not connect spark plug wires.
- Clean the generator outer surfaces. Check that cooling air slots and openings on generator are open and unobstructed.
- Store the unit in a clean, dry place.

3.8 OTHER STORAGE TIPS

- Do not store gasoline from one season to another.
- Replace the gasoline can if it starts to rust. Rust and/or dirt in the gasoline will cause problems with the carburetor and fuel system.
- If possible, store the unit indoors and cover it to give protection from dust and dirt. **BE SURE TO EMPTY THE FUEL TANK.**
- If it is not practical to empty the fuel tank and the unit is to be stored for some time, use a commercially available fuel stabilizer added to the gasoline to increase the life of the gasoline.
- Cover the unit with a suitable protective cover that does not retain moisture.



NEVER cover the generator while engine and exhaust area are warm.



4.1 TROUBLESHOOTING GUIDE

| PROBLEM | CAUSE | CORRECTION |
|--|--|---|
| Engine is running, but no AC output is available. | <ol style="list-style-type: none"> 1. Circuit breaker is open. 2. Poor connection or defective cord set. 3. Connected device is bad. 4. Fault in generator. | <ol style="list-style-type: none"> 1. Reset circuit breaker. 2. Check and repair. 3. Connect another device that is in good condition. 4. Contact Authorized Service Facility. |
| Engine runs good but bogs down when loads are connected. | <ol style="list-style-type: none"> 1. Short circuit in a connected load. 2. Generator is overloaded. 3. Engine speed is too slow. 4. Shorted generator circuit. | <ol style="list-style-type: none"> 1. Disconnect shorted electrical load. 2. See "Don't Overload the Generator" . 3. Contact Authorized Service Facility. 4. Contact Authorized Service Facility. |
| Engine will not start; or starts and runs rough. | <ol style="list-style-type: none"> 1. Dirty air filter. 2. Out of gasoline. 3. Stale gasoline. 4. Spark plug wire not connected to spark plug. 5. Bad spark plug. 6. Water in gasoline. 7. Overchoking. 8. Low oil level. 9. Excessive rich fuel mixture. 10. Intake valve stuck open or closed. 11. Engine has lost compression. | <ol style="list-style-type: none"> 1. Clean or replace air filter. 2. Fill fuel tank. 3. Drain fuel tank and fill with fresh fuel. 4. Connect wire to spark plug. 5. Replace spark plug. 6. Drain fuel tank; fill with fresh fuel. 7. Put choke knob to No Choke position. 8. Fill crankcase to proper level. 9. Contact Authorized Service Facility. 10. Contact Authorized Service Facility. 11. Contact Authorized Service Facility. |
| Engine shuts down during operation. | <ol style="list-style-type: none"> 1. Out of gasoline. 2. Low oil level. 3. Fault in engine. | <ol style="list-style-type: none"> 1. Fill fuel tank. 2. Fill crankcase to proper level. 3. Contact Authorized Service Facility. |
| Engine lacks power. | <ol style="list-style-type: none"> 1. Load is too high. 2. Dirty air filter. 3. Engine needs to be serviced. | <ol style="list-style-type: none"> 1. Reduce load (see "Don't Overload the Generator"). 2. Clean or replace air filter. 3. Contact Authorized Service Facility. |
| Engine "hunts" or falters. | <ol style="list-style-type: none"> 1. Choke is opened too soon. 2. Carburetor is running too rich or too lean. | <ol style="list-style-type: none"> 1. Move choke to halfway position until engine runs smoothly. 2. Contact Authorized Service Facility. |



Section 6 — Warranty

Portable Generator System

GENERAC POWER SYSTEMS “TWO YEAR” LIMITED WARRANTY FOR GP SERIES PORTABLE GENERATORS

For a period of two years from the date of original sale, Generac Power Systems, Inc. (Generac) warrants its GP Series generators will be free from defects in materials and workmanship for the items and period set forth below. Generac will, at its option, repair or replace any part which, upon examination, inspection and testing by Generac or a Generac Authorized Warranty Service Dealer, is found to be defective. Any equipment that the purchaser/owner claims to be defective must be returned to and examined by the nearest Generac Authorized Warranty Service Dealer. All transportation costs under the warranty, including return to the factory, are to be borne and prepaid by the purchaser/owner. This warranty applies only to Generac GP Series portable generators and is not transferable from original purchaser. Save your proof-of-purchase receipt. If you do not provide proof of the initial purchase date, the manufacturer's shipping date of the product will be used to determine the warranty period.

WARRANTY SCHEDULE

Consumer applications are warranted for two (2) years. Commercial and Rental applications are warranted for one (1) year or 1000 hours maximum, whichever comes first.

CONSUMER APPLICATION

YEARS ONE and TWO - 100% (one hundred percent) coverage on Labor and Part(s) listed (proof of purchase and maintenance is required):

- Engine- All Components
- Alternator- All Components

COMMERCIAL/RENTAL APPLICATION

YEAR ONE – 100% (one hundred percent) coverage on Labor and Part(s) listed (proof of purchase and maintenance is required):

- Engine- All Components
- Alternator- All Components

NOTE: For the purpose of this warranty “consumer use” means personal residential household or recreational use by original purchaser. This warranty does not apply to units used for Prime Power in place of utility where utility power service is present or where utility power service does not normally exist. Once a generator has experienced commercial or rental use, it shall thereafter be considered a non-consumer use generator for the purpose of this warranty.

All warranty expense allowances are subject to the conditions defined in Generac's Warranty Policies, Procedures and Flat Rate Manual.

THIS WARRANTY SHALL NOT APPLY TO THE FOLLOWING:

- Generac built portable generators built prior to May 2008.
- Generac portable generators that utilize non-Generac replacement parts.
- Costs of normal maintenance and adjustments.
- Failures caused by any contaminated fuels, oils or lack of proper oil levels.
- Repairs or diagnostics performed by individuals other than Guardian/Generac authorized dealers not authorized in writing by Generac Power Systems.
- Failures due, but not limited, to normal wear and tear, accident, misuse, abuse, negligence or improper use. As with all mechanical devices, the Generac engines need periodic part(s) service and replacement to perform as designed. This warranty will not cover repair when normal use has exhausted the life of a part(s) or engine.
- Failures caused by any external cause or act of God, such as collision, theft, vandalism, riot or wars, nuclear holocaust, fire, freezing, lightning, earth-quake, windstorm, hail, volcanic eruption, water or flood, tornado or hurricane.
- Damage related to rodent and/or insect infestation.
- Products that are modified or altered in a manner not authorized by Generac in writing.
- Any incidental, consequential or indirect damages caused by defects in materials or workmanship, or any delay in repair or replacement of the defective part(s).
- Failure due to misapplication.
- Telephone, cellular phone, facsimile, internet access or other communication expenses.
- Living or travel expenses of person(s) performing service, except as specifically included within the terms of a specific unit warranty period.
- Expenses related to “customer instruction” or troubleshooting where no manufacturing defect is found.
- Rental equipment used while warranty repairs are being performed.
- Overnight freight or special shipping costs for replacement part(s).
- Overtime, holiday or emergency labor.
- Starting batteries, fuses, light bulbs and engine fluids.

THIS WARRANTY IS IN PLACE OF ALL OTHER WARRANTIES, EXPRESSED OR IMPLIED. SPECIFICALLY, GENERAC MAKES NO OTHER WARRANTIES AS TO THE MERCHANTABILITY OR FITNESS FOR A PARTICULAR PURPOSE. Some states do not allow limitations on how long an implied warranty lasts, so the above limitation may not apply to you. GENERAC'S ONLY LIABILITY SHALL BE THE REPAIR OR REPLACEMENT OF PART(S) AS STATED ABOVE. IN NO EVENT SHALL GENERAC BE LIABLE FOR ANY INCIDENTAL OR CONSEQUENTIAL DAMAGES, EVEN IF SUCH DAMAGES ARE A DIRECT RESULT OF GENERAC'S NEGLIGENCE. Some states do not allow the exclusion or limitation of incidental or consequential damages, so the above limitation may not apply to you. This warranty gives you specific legal rights. You also have other rights from state to state.

GENERAC POWER SYSTEMS, INC.

P.O. BOX 8 • Waukesha, WI 53187

Ph: (888) GENERAC (436-3722) • Fax: (262) 544-4851

To locate the nearest Authorized Dealer visit our website www.generac.com